

*In-person participation by the public will be permitted. In addition, remote public participation is available in the following ways:*

- *Livestream online at [www.atwater.org](http://www.atwater.org) (Please be advised that there is a broadcasting delay. If you would like to participate in public comment, please use the option below).*
- *Submit a written public comment prior to the meeting: Public comments submitted to [cityclerk@atwater.org](mailto:cityclerk@atwater.org) by 4:00 p.m. on the day of the meeting will be distributed to the City Council, and made part of the official minutes but will not be read out loud during the meeting.*

*Assistance will be provided to those requiring accommodations for disabilities in compliance with the Americans with Disabilities Act of 1990. Persons requesting accommodation should contact the City in advance of the meeting, and as soon as possible, at (209) 357-6241.*

**CITY OF ATWATER  
CITY COUNCIL,  
FIRE PROTECTION DISTRICT,  
AND  
SUCCESSOR AGENCY TO THE ATWATER  
REDEVELOPMENT AGENCY**

**AGENDA**

Council Chambers  
750 Bellevue Road  
Atwater, California

**June 9, 2025**

REGULAR SESSION: (Council Chambers)

CALL TO ORDER:

**6:00 PM**

INVOCATION:

PLEDGE OF ALLEGIANCE TO THE FLAG:

ROLL CALL: (City Council/Board of Directors)

**Ambriz** \_\_\_\_, **Cale** \_\_\_\_, **Raymond** \_\_\_\_, **Rochester** \_\_\_\_, **Nelson** \_\_\_\_\_

SUBSEQUENT NEED ITEMS: (The City Clerk shall announce any requests for items requiring immediate action subsequent to the posting of the agenda. Subsequent need items require a two-thirds vote of the members of the City Council present at the meeting.)

APPROVAL OF AGENDA AS POSTED OR AS AMENDED: (This is the time for the City Council to remove items from the agenda or to change the order of the agenda.)

PRESENTATIONS:

**1. Certificate of Recognition - Atwater High School Forensics Class**

**Staff's Recommendation:** That Mayor Nelson on behalf of the City Council recognize the exceptional accomplishments of the Atwater High School Forensics team that competed in a recent statewide Crime Scene Investigation (CSI) competition.

CONSENT CALENDAR:

NOTICE TO THE PUBLIC

Background information has been provided on all matters listed under the Consent Calendar, and these items are considered to be routine. All items under the Consent Calendar are normally approved by one motion. If a Councilmember requests separate discussion on any item, that item will be removed from the Consent Calendar for separate action.

WARRANTS:

**2. June 9, 2025**

**Staff's Recommendation:** Approval of warrants as listed.

RESOLUTIONS:

**3. Approval of the Statement of Investment Policy for the 2025-26 Fiscal Year and Delegating Authority to the City Treasurer to Invest Funds in Accordance with the Statement of Investment Policy** (Finance Director Nicholas)

**Staff's Recommendation:** Adoption of Resolution No. 3536-25 approving the Statement of Investment Policy for Fiscal Year 2025-26 and delegating authority to the City Treasurer to invest funds in accordance with the Statement of Investment Policy.

\*\*\*END OF CONSENT CALENDAR\*\*\*

PUBLIC HEARINGS:

**4. Adopting a Resolution Setting the Fiscal Year 2025-26 Miscellaneous Fee Schedule** (Finance Director Nicholas)

**Staff's Recommendation:** Open the Public Hearing and receive any testimony given regarding the proposed 2025-26 Miscellaneous Fee Schedule;

Close the Public Hearing;

Motion to adopt Resolution No. 3537-25 setting the City of Atwater's Miscellaneous Fee Schedule for Fiscal Year 2025-26; or

Motion to approve staff's recommendation as presented.

**5. Resolutions Adopting the Fiscal Year 2025-26 Budget including Five-Year Capital Improvement Plan and Approving Fund Expenditures and Fund Transfers; Establishing Appropriations Limitations; and Amending Classification Plan and Adopting Salary Schedule A-26 Effective June 20, 2025** (City Manager/Executive Director Hoem, Human Resources Director Sousa, and Finance Director/Treasurer Nicholas)

**Staff's Recommendation:** Open the Public Hearing and receive any testimony given regarding the Fiscal Year 2025-26 Budget;

Close the Public Hearing;

Motion to adopt Joint Authority Resolution No. 3538-25, Resolution No. AFD 1-2025, and Resolution No. SA 2025-1 adopting the Fiscal Year 2025-26 budget, approving Fund Expenditures and Fund Transfers, and a Five-Year Capital Improvement Program with any modifications from the budget review and public hearing; to adopt Resolution No. 3539-25 establishing the Fiscal Year 2025-26 Appropriations Limitation; to adopt Resolution No. 3540-25 amending the City of Atwater Classification Plan and adopting Salary Schedule A-26, effective June 19, 2025; or

Motion to approve staff's recommendation as presented.

REPORTS AND PRESENTATIONS FROM STAFF:

**6. Approving a Cost Share Agreement with Merced County for a Fire Equipment Mechanic** (CAL Fire Battalion Chief Ayuso)

**Staff's Recommendation:** Motion to adopt Resolution No. 3543-25 Approving a Cost Share Agreement, in a form approved by the City Attorney, with the County of Merced, from July 1, 2025, to June 30, 2026, for a Fire Equipment Mechanic for Heavy Equipment in an amount not to exceed \$65,000; and authorizes and directs the City Manager to execute all contract documents on behalf of the City; or

Motion to approve staff's recommendation as presented.

7. **Awarding a General Construction Contract with Consolidated Engineering Inc. for Olive Avenue Overlay** (Public Works Director Vinson)  
**Staff's Recommendation:** Motion to adopt a Resolution 3542-25 awarding a General Construction Contract, in a form approved by the City Attorney, to Consolidated Engineering Inc. of Valley Springs, CA, for the Olive Avenue Overlay Project, City Project 24-07, in an amount not to exceed \$447,327.00 and authorizes construction contract change orders up to an aggregate amount of \$44,732.70 (10%); and authorizes and directs the Interim City Manager or designee to execute all contract documents on behalf of the City; or

Motion to approve staff's recommendations as presented.

8. **Community Development Director Employment Agreement** (City Manager Hoem)  
**Staff's Recommendation:** Motion to adopt Resolution No. 3541-25 to ratify the Community Development Director Employment Agreement in the annual amount of \$135,657.96 plus benefits with Jon O'Connor, in a form approved by the City Attorney; and authorize and direct the City Manager to execute the Agreement on behalf of the City; or

Motion to approve staff's recommendation as presented.

COMMENTS FROM THE PUBLIC:

NOTICE TO THE PUBLIC

At this time any person may comment on any item which is not on the agenda. You may state your name and address for the record; however, it is not required. Action will not be taken on an item that is not on the agenda. If it requires action, it will be referred to staff and/or placed on a future agenda. Please limit comments to a maximum of three (3) minutes.

CITY COUNCIL REPORTS/UPDATES

- **Mayor Pro Tem Cale, District 1**
- **City Council Member Rochester, District 2**
- **City Council Member Ambriz, District 3**
- **City Council Member Raymond, District 4**
- **Mayor Nelson**

CITY MANAGER REPORTS/UPDATES:

9. **Update from the City Manager**

ADJOURNMENT:

CERTIFICATION:

I, Kory J. Billings, City Clerk of the City of Atwater, do hereby certify that a copy of the foregoing agenda was posted at City Hall a minimum of 72 hours prior to the meeting.

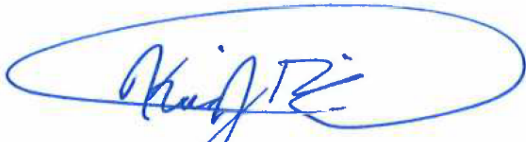

---

KORY J. BILLINGS  
CITY CLERK

SB 343 NOTICE

*In accordance with California Government Code Section 54957.5, any writing or document that is a public record, relates to an open session agenda item and is distributed less than 72 hours prior to a regular meeting will be made available for public inspection in the office of the City Clerk at City Hall during normal business hours at 750 Bellevue Road.*

*If, however, the document or writing is not distributed until the regular meeting to which it relates, then the document or writing will be made available to the public at the location of the meeting, as listed on this agenda at 750 Bellevue Road.*





*In compliance with the federal Americans with Disabilities Act of 1990, upon request, the agenda can be provided in an alternative format to accommodate special needs. If you require special accommodations to participate in a City Council, Commission or Committee meeting due to a disability, please contact the City Clerk's Office a minimum of three (3) business days in advance of the meeting at (209) 357-6241. You may also send the request by email to [cityclerk@atwater.org](mailto:cityclerk@atwater.org).*

*Unless otherwise noted, City Council actions include a determination that they are not a "Project" within the meaning of the California Environmental Quality Act (CEQA), and therefore, that CEQA does not apply to such actions.*

# JUNE



**SUN                      MON                      TUE                      WED                      THU                      FRI                      SAT**

1	2	3	4	5	6	7
8	9 City Council Meeting - 6:00 PM	10	11	12	13 Movie in the Park 🎬 The Wild Robot Ralston Park	14
15	16	17	18 Planning Commission Meeting - 6:00 PM	19  City Holiday Trash pick up delayed - 1 day	20	21
22	23 Audit & Finance Meeting - 5:00 PM City Council Meeting - 6:00 PM	24	25	26 Scan QR Code for info regarding mobile office hours 	27	28
29	30					

# JULY



SUN	MON	TUE	WED	THU	FRI	SAT
		1	2	3	4  City Holiday Trash pick up delayed - 1 day	5
6 	7	8	9	10	11 Movie in the Park  Moana 2 Veterans Park	12
13	14 City Council Meeting - 6:00 PM	15	16 Planning Commission Meeting - 6:00 PM	17	18	19
20	21	22	23	24 Scan QR Code for info regarding mobile office hours 	25	26
27	28	29	30	31		

## Warrant Summary June 9, 2025

Prepared By: Joseph Murillo, Accounting Technician  
Accounts Payable Warrant

	Amount
6/9/2025 Warrant	\$ 2,322,799.00
Prewrittens (Checks Processed Between Warrants)	\$ 229,990.35
<b>Total Accounts Payable Warrants:</b>	<b>\$ 2,552,789.35</b>

### Additional Warrants

Date	Description	Amount
5/28/2025	Quadient Finance (Postage)	\$ 5,403.27
5/29/2025	Chase Merchant Service	\$ 542.66
5/30/2025	Retiree Medical Reimbursement - June 2025	\$ 54,904.98
6/2/2025	PERS Retirement 5/8/25-5/21/25	\$ 58,064.42
6/2/2025	State Disbursement - Child Support 5/29/25 Payroll	\$ 115.38
6/3/2025	PERS Health - May 2025	\$ 125,216.57
<b>Total Additional Warrants:</b>		<b>\$ 244,247.28</b>

### Payroll

Date	Description	Amount
5/29/2025	Net Payroll	\$ 200,739.74
6/2/2025	Federal Taxes	\$ 63,864.48
6/2/2025	State Taxes	\$ 8,103.56
6/2/2025	Federal Taxes	\$ 37.76
6/2/2025	Federal Taxes	\$ 52.86
<b>Total Payroll:</b>		<b>\$ 272,707.78</b>

**Grand Total:** **\$ 3,069,744.41**

  
\_\_\_\_\_  
Anna Nicholas, Finance Director

  
\_\_\_\_\_  
Mark Borba, City Treasurer

# Accounts Payable

## Checks for Approval

User: jmurillo  
 Printed: 6/5/2025 - 12:12 PM



City of  
**Atwater**  
 Community Pride City Wide

760 Bellevue Road, Atwater CA 95301

Check Number	Check Date	Fund	Account Name	Vendor Name	Void	Amount
0	05/28/2025	0001 General Fund	Office Supplies	QUADIENT FINANCE USA INC		1,597.80
0	05/28/2025	0001 General Fund	Office Supplies	QUADIENT FINANCE USA INC		1,725.22
0	05/28/2025	0001 General Fund	Office Supplies	QUADIENT FINANCE USA INC		2,080.25
Check Total:						5,403.27
0	05/29/2025	0001 General Fund	Special Departmental Expense	CHASE MERCHANT SERVICES		542.66
Check Total:						542.66
0	05/30/2025	7010 Employee Benefits Fund	Health Insurance, Retirees	GLEN C. CARRINGTON		240.03
0	05/30/2025	7010 Employee Benefits Fund	Health Insurance, Retirees	JOHN RASMUSSEN		832.46
0	05/30/2025	7010 Employee Benefits Fund	Health Insurance, Retirees	ARMANDO ECHEVARRIA		886.51
0	05/30/2025	7010 Employee Benefits Fund	Health Insurance, Retirees	GREG WELLMAN		854.46
0	05/30/2025	7010 Employee Benefits Fund	Health Insurance, Retirees	LOIS BELT		368.23
0	05/30/2025	7010 Employee Benefits Fund	Health Insurance, Retirees	JOHN SMOTHERS		823.15
0	05/30/2025	7010 Employee Benefits Fund	Health Insurance, Retirees	KELLY SORENSEN		1,488.33
0	05/30/2025	7010 Employee Benefits Fund	Health Insurance, Retirees	BILL SWALLEY		240.03
0	05/30/2025	7010 Employee Benefits Fund	Health Insurance, Retirees	LINDA FERRERO		368.23
0	05/30/2025	7010 Employee Benefits Fund	Health Insurance, Retirees	KAREN ARDEN-WALLER		380.74
0	05/30/2025	7010 Employee Benefits Fund	Health Insurance, Retirees	CHARLIE WOODS		832.46
0	05/30/2025	7010 Employee Benefits Fund	Health Insurance, Retirees	BARBARA RIIS CHRISTENSEN		822.46
0	05/30/2025	7010 Employee Benefits Fund	Health Insurance, Retirees	WILLIAM MARTIN		886.51
0	05/30/2025	7010 Employee Benefits Fund	Health Insurance, Retirees	MARGARET MERRITT		240.03
0	05/30/2025	7010 Employee Benefits Fund	Health Insurance, Retirees	ALLAN BOYER		894.46
0	05/30/2025	7010 Employee Benefits Fund	Health Insurance, Retirees	FRANK ORMOND		245.45
0	05/30/2025	7010 Employee Benefits Fund	Health Insurance, Retirees	MATTHEW PETERSON-HAYWOOD		573.25
0	05/30/2025	7010 Employee Benefits Fund	Health Insurance, Retirees	JEFF MONDLOCH		306.23
0	05/30/2025	7010 Employee Benefits Fund	Health Insurance, Retirees	BOBBY GREGORY		2,557.71
0	05/30/2025	7010 Employee Benefits Fund	Health Insurance, Retirees	DARIN JANTZ		1,606.29
0	05/30/2025	7010 Employee Benefits Fund	Health Insurance, Retirees	CYNTHIA THOMPSON		368.23
0	05/30/2025	7010 Employee Benefits Fund	Health Insurance, Retirees	ADOLFO LOMELI		1,099.13
0	05/30/2025	7010 Employee Benefits Fund	Health Insurance, Retirees	DOUGLAS P. TILLEY		368.23
0	05/30/2025	7010 Employee Benefits Fund	Health Insurance, Retirees	DENNIS O. SPARKS		368.23
0	05/30/2025	7010 Employee Benefits Fund	Health Insurance, Retirees	LEN GUILLETTE		1,152.38

Check Number	Check Date	Fund	Account Name	Vendor Name	Void	Amount
0	05/30/2025	7010 Employee Benefits Fund	Health Insurance, Retirees	STANLEY FEATHERS		832.46
0	05/30/2025	7010 Employee Benefits Fund	Health Insurance, Retirees	STEPHEN LUNDGREN		280.80
0	05/30/2025	7010 Employee Benefits Fund	Health Insurance, Retirees	GEORGE LOGAN		368.23
0	05/30/2025	7010 Employee Benefits Fund	Health Insurance, Retirees	FRANK PIETRO		734.76
0	05/30/2025	7010 Employee Benefits Fund	Health Insurance, Retirees	MANUEL DURAN		145.67
0	05/30/2025	7010 Employee Benefits Fund	Health Insurance, Retirees	DAVID WALKER		676.68
0	05/30/2025	7010 Employee Benefits Fund	Health Insurance, Retirees	TONY RAMIREZ		972.99
0	05/30/2025	7010 Employee Benefits Fund	Health Insurance, Retirees	BENJAMIN THOMAS		1,522.58
0	05/30/2025	7010 Employee Benefits Fund	Health Insurance, Retirees	RANDALL CARROTHERS		1,696.72
0	05/30/2025	7010 Employee Benefits Fund	Health Insurance, Retirees	LORIN MANN		726.15
0	05/30/2025	7010 Employee Benefits Fund	Health Insurance, Retirees	CHRISTOPHER A. MCDANIEL		368.23
0	05/30/2025	7010 Employee Benefits Fund	Health Insurance, Retirees	ROBERT CALLAWAY		822.46
0	05/30/2025	7010 Employee Benefits Fund	Health Insurance, Retirees	RICHARD HAWTHORNE		822.46
0	05/30/2025	7010 Employee Benefits Fund	Health Insurance, Retirees	DICK WISDOM		240.03
0	05/30/2025	7010 Employee Benefits Fund	Health Insurance, Retirees	HARRY E. DUNN		832.46
0	05/30/2025	7010 Employee Benefits Fund	Health Insurance, Retirees	MICHAEL SALVADOR		86.00
0	05/30/2025	7010 Employee Benefits Fund	Health Insurance, Retirees	THOMAS PROTHRO		245.45
0	05/30/2025	7010 Employee Benefits Fund	Health Insurance, Retirees	NANCY WILLIAMS		368.23
0	05/30/2025	7010 Employee Benefits Fund	Health Insurance, Retirees	NELSON CRABB		846.46
0	05/30/2025	7010 Employee Benefits Fund	Health Insurance, Retirees	LORI WATERMAN		754.33
0	05/30/2025	7010 Employee Benefits Fund	Health Insurance, Retirees	KEN JENSEN		461.15
0	05/30/2025	7010 Employee Benefits Fund	Health Insurance, Retirees	JOSEPH HOFFAR		638.05
0	05/30/2025	7010 Employee Benefits Fund	Health Insurance, Retirees	STEVE KJOS		832.46
0	05/30/2025	7010 Employee Benefits Fund	Health Insurance, Retirees	DAVID CHURCH		719.61
0	05/30/2025	7010 Employee Benefits Fund	Health Insurance, Retirees	SCOTT DUNCAN		1,915.18
0	05/30/2025	7010 Employee Benefits Fund	Health Insurance, Retirees	SANDY GLOWSKI		843.61
0	05/30/2025	7010 Employee Benefits Fund	Health Insurance, Retirees	ELIZABETH WILDE		886.51
0	05/30/2025	7010 Employee Benefits Fund	Health Insurance, Retirees	JESUS F. DURAN		1,732.78
0	05/30/2025	7010 Employee Benefits Fund	Health Insurance, Retirees	ANTHONY CARDOZA		895.15
0	05/30/2025	7010 Employee Benefits Fund	Health Insurance, Retirees	CHRISTIAN HAMBRECHT		895.15
0	05/30/2025	7010 Employee Benefits Fund	Health Insurance, Retirees	MICHAEL KEELER		1,298.61
0	05/30/2025	7010 Employee Benefits Fund	Health Insurance, Retirees	MIKE STANFORD		1,053.79
0	05/30/2025	7010 Employee Benefits Fund	Health Insurance, Retirees	PATRICK FARETTA		1,684.75
0	05/30/2025	7010 Employee Benefits Fund	Health Insurance, Retirees	WILLIAM RICHARDS		245.45
0	05/30/2025	7010 Employee Benefits Fund	Health Insurance, Retirees	EARL WEATHERS		832.46
0	05/30/2025	7010 Employee Benefits Fund	Health Insurance, Retirees	ROBERT VASQUEZ		333.52
0	05/30/2025	7010 Employee Benefits Fund	Health Insurance, Retirees	JERRY MOORE		822.46
0	05/30/2025	7010 Employee Benefits Fund	Health Insurance, Retirees	RENE MENDOZA		822.46
0	05/30/2025	7010 Employee Benefits Fund	Health Insurance, Retirees	TYNA LAMISON		701.03
0	05/30/2025	7010 Employee Benefits Fund	Health Insurance, Retirees	GARY FRAGO		590.05
0	05/30/2025	7010 Employee Benefits Fund	Health Insurance, Retirees	SAMUEL JOSEPH		1,521.62
0	05/30/2025	7010 Employee Benefits Fund	Health Insurance, Retirees	ROBERTO ROMERO		606.47
0	05/30/2025	7010 Employee Benefits Fund	Health Insurance, Retirees	DEBRA COURT		245.45
0	05/30/2025	7010 Employee Benefits Fund	Health Insurance, Retirees	EDWARD VELASQUEZ		240.03

Check Number	Check Date	Fund	Account Name	Vendor Name	Void	Amount
0	05/30/2025	7010 Employee Benefits Fund	Health Insurance, Retirees	JUAN SUFUENTES		1,700.78
0	05/30/2025	7010 Employee Benefits Fund	Health Insurance, Retirees	JAMES ATKINSON		240.03
Check Total:						54,904.98
0	05/30/2025	0001 General Fund	Fica/Medicare-Employer	PAYROLL TAXES-FEDERAL		10.02
0	05/30/2025	0001 General Fund	Fica/Medicare-Employer	PAYROLL TAXES-FEDERAL		42.84
Check Total:						52.86
0	06/02/2025	0001 General Fund	Fica/Medicare-Employer	PAYROLL TAXES-FEDERAL		7.16
0	06/02/2025	0001 General Fund	Fica/Medicare-Employer	PAYROLL TAXES-FEDERAL		30.60
Check Total:						37.76
0	06/03/2025	0001 General Fund	Pers Health Payable	PERS-HEALTH		111,607.82
0	06/03/2025	7010 Employee Benefits Fund	General Administration-Ins	PERS-HEALTH		267.86
0	06/03/2025	7010 Employee Benefits Fund	Health Insurance, Retirees	PERS-HEALTH		1,918.35
0	06/03/2025	7010 Employee Benefits Fund	Health Insurance, Retirees	PERS-HEALTH		11,218.00
0	06/03/2025	7010 Employee Benefits Fund	Health Insurance, Retirees	PERS-HEALTH		199.94
0	06/03/2025	0001 General Fund	Miscellaneous Bills	PERS-HEALTH		4.60
Check Total:						125,216.57
0	06/02/2025	0001 General Fund	Fica/Medicare - Employee	PAYROLL TAXES-FEDERAL		4,008.11
0	06/02/2025	0001 General Fund	State Income Tax Withheld	PAYROLL TAXES-STATE		8,103.56
0	06/02/2025	0001 General Fund	Federal Income Tax Withheld	PAYROLL TAXES-FEDERAL		21,519.28
0	06/02/2025	0001 General Fund	Fica/Medicare-Employer	PAYROLL TAXES-FEDERAL		10.02
0	06/02/2025	0001 General Fund	Pers Benefits	PERS-RETIREMENT		6,494.89
0	06/02/2025	0001 General Fund	Fica/Medicare - Employee	PAYROLL TAXES-FEDERAL		17,138.06
0	06/02/2025	0001 General Fund	Pers Benefits	PERS-RETIREMENT		-0.03
0	06/02/2025	0001 General Fund	Pers Benefits	PERS-RETIREMENT		9,078.55
0	06/02/2025	0001 General Fund	Pers Deduction	PERS-RETIREMENT		8,674.83
0	06/02/2025	0001 General Fund	Pers Deduction	PERS-RETIREMENT		2,582.81
0	06/02/2025	0001 General Fund	Pers Benefits	PERS-RETIREMENT		16,666.09
0	06/02/2025	0001 General Fund	Fica/Medicare-Employer	PAYROLL TAXES-FEDERAL		4,008.11
0	06/02/2025	0001 General Fund	Garnishments	STATE DISBURSEMENT UNIT		115.38
0	06/02/2025	0001 General Fund	Fica/Medicare-Employer	PAYROLL TAXES-FEDERAL		17,138.06
0	06/02/2025	0001 General Fund	Pers Deduction	PERS-RETIREMENT		871.92
0	06/02/2025	0001 General Fund	Fica/Medicare-Employer	PAYROLL TAXES-FEDERAL		42.84
0	06/02/2025	0001 General Fund	Pers Benefits	PERS-RETIREMENT		2,828.13
0	06/02/2025	0001 General Fund	Pers Benefits	PERS-RETIREMENT		8,940.11
0	06/02/2025	0001 General Fund	Pers Benefits	PERS-RETIREMENT		786.58
0	06/02/2025	0001 General Fund	Pers Benefits	PERS-RETIREMENT		1,140.54

Check Number	Check Date	Fund	Account Name	Vendor Name	Void	Amount
Check Total:						130,147.84
Report Total:						316,305.94

Accounts Payable  
Checks for Approval

*Prumptions*



City of  
**Atwater**  
Community Pride City Wide

750 Bellevue Road, Atwater CA 95301

User: jmurillo  
Printed: 6/5/2025 - 12:07 PM

Check Number	Check Date	Fund	Account Name	Vendor Name	Void	Amount
28124	05/29/2025	7010 Employee Benefits Fund	Disability Insurance	FIRST UNUM LIFE INSURANCE COMPANY		3,547.40
28124	05/29/2025	7010 Employee Benefits Fund	Disability Insurance	FIRST UNUM LIFE INSURANCE COMPANY		1,872.00
28124	05/29/2025	7010 Employee Benefits Fund	Disability Insurance	FIRST UNUM LIFE INSURANCE COMPANY		1,090.09
Check Total:						6,509.49
28125	05/29/2025	0001 General Fund	Professional Services	GERALD HARRISON		4,411.19
28125	05/29/2025	0001 General Fund	Planning Deposits	GERALD HARRISON		3,588.81
Check Total:						8,000.00
28126	05/29/2025	5019 Airport Business Park LD	Utilities	PACIFIC GAS & ELECTRIC		58.54
28126	05/29/2025	1011 Gas Tax/Street Improvement	Utilities	PACIFIC GAS & ELECTRIC		408.47
28126	05/29/2025	0001 General Fund	Utilities	PACIFIC GAS & ELECTRIC		8,646.95
28126	05/29/2025	5036 Atwater South LD	Utilities	PACIFIC GAS & ELECTRIC		44.79
28126	05/29/2025	5004 Woodview Garland LA	Utilities	PACIFIC GAS & ELECTRIC		17.69
28126	05/29/2025	5017 Cottage Gardens LD	Utilities	PACIFIC GAS & ELECTRIC		25.85
28126	05/29/2025	5001 Northwood Village LD	Utilities	PACIFIC GAS & ELECTRIC		207.75
28126	05/29/2025	5001 Northwood Village LD	Utilities	PACIFIC GAS & ELECTRIC		397.46
28126	05/29/2025	1011 Gas Tax/Street Improvement	Utilities	PACIFIC GAS & ELECTRIC		16,036.18
28126	05/29/2025	5002 Orchard Park Estates LD	Utilities	PACIFIC GAS & ELECTRIC		103.39
28126	05/29/2025	5003 Wildwood Estates LD	Utilities	PACIFIC GAS & ELECTRIC		55.70
28126	05/29/2025	6010 Sewer Enterprise Fund	Utilities	PACIFIC GAS & ELECTRIC		247.73
28126	05/29/2025	5007 Sierra Parks LD	Utilities	PACIFIC GAS & ELECTRIC		28.98
28126	05/29/2025	5008 Shaffer Lakes East LD	Utilities	PACIFIC GAS & ELECTRIC		238.83
28126	05/29/2025	6010 Sewer Enterprise Fund	Utilities	PACIFIC GAS & ELECTRIC		4,693.72
28126	05/29/2025	0001 General Fund	Utilities	PACIFIC GAS & ELECTRIC		8,761.68
28126	05/29/2025	5006 Woodhaven LD	Utilities	PACIFIC GAS & ELECTRIC		19.50
28126	05/29/2025	7000 Internal Service Fund	Utilities	PACIFIC GAS & ELECTRIC		1,564.58
28126	05/29/2025	5013 Pajaro Dunes LD	Utilities	PACIFIC GAS & ELECTRIC		28.28
28126	05/29/2025	5011 Sandlewood Square LD	Utilities	PACIFIC GAS & ELECTRIC		31.83
28126	05/29/2025	0001 General Fund	Utilities	PACIFIC GAS & ELECTRIC		1,655.67
28126	05/29/2025	0001 General Fund	Utilities	PACIFIC GAS & ELECTRIC		1,834.82
28126	05/29/2025	5005 Shaffer Lakes West LD	Utilities	PACIFIC GAS & ELECTRIC		59.15
28126	05/29/2025	0001 General Fund	Utilities	PACIFIC GAS & ELECTRIC		378.13

Check Number	Check Date	Fund	Account Name	Vendor Name	Void	Amount
28126	05/29/2025	5007 Sierra Parks LD	Utilities	PACIFIC GAS & ELECTRIC		28.98
28126	05/29/2025	5011 Sandlewood Square LD	Utilities	PACIFIC GAS & ELECTRIC		31.83
28126	05/29/2025	5036 Atwater South LD	Utilities	PACIFIC GAS & ELECTRIC		-16.36
28126	05/29/2025	5002 Orchard Park Estates LD	Utilities	PACIFIC GAS & ELECTRIC		173.84
28126	05/29/2025	5017 Cottage Gardens LD	Utilities	PACIFIC GAS & ELECTRIC		-33.51
28126	05/29/2025	7000 Internal Service Fund	Operations & Maintenance	PACIFIC GAS & ELECTRIC		1,263.55
28126	05/29/2025	6000 Water Enterprise Fund	Utilities	PACIFIC GAS & ELECTRIC		40,109.63
28126	05/29/2025	6000 Water Enterprise Fund	Utilities	PACIFIC GAS & ELECTRIC		23,462.03
28126	05/29/2025	5005 Shaffer Lakes West LD	Utilities	PACIFIC GAS & ELECTRIC		59.15
28126	05/29/2025	5009 Price Annexation LD	Utilities	PACIFIC GAS & ELECTRIC		905.97
28126	05/29/2025	5006 Woodhaven LD	Utilities	PACIFIC GAS & ELECTRIC		19.48
28126	05/29/2025	7000 Internal Service Fund	Utilities	PACIFIC GAS & ELECTRIC		5,286.08
28126	05/29/2025	5004 Woodview Garland LA	Utilities	PACIFIC GAS & ELECTRIC		17.68
28126	05/29/2025	5019 Airport Business Park LD	Utilities	PACIFIC GAS & ELECTRIC		118.83
28126	05/29/2025	5008 Shaffer Lakes East LD	Utilities	PACIFIC GAS & ELECTRIC		238.86
28126	05/29/2025	5003 Wildwood Estates LD	Utilities	PACIFIC GAS & ELECTRIC		10.73
28126	05/29/2025	6000 Water Enterprise Fund	Utilities	PACIFIC GAS & ELECTRIC		56,600.39
28126	05/29/2025	6010 Sewer Enterprise Fund	Utilities	PACIFIC GAS & ELECTRIC		3,477.90
28126	05/29/2025	1011 Gas Tax/Street Improvement	Utilities	PACIFIC GAS & ELECTRIC		15,987.51
28126	05/29/2025	5013 Pajaro Dunes LD	Utilities	PACIFIC GAS & ELECTRIC		28.28
28126	05/29/2025	7000 Internal Service Fund	Utilities	PACIFIC GAS & ELECTRIC		5,338.50
28126	05/29/2025	5009 Price Annexation LD	Utilities	PACIFIC GAS & ELECTRIC		1,143.97
28126	05/29/2025	0001 General Fund	Utilities	PACIFIC GAS & ELECTRIC		1,788.94
Check Total:						201,587.93
28127	05/29/2025	0001 General Fund	Professional Services	PAUL HARRISON CO INC		13,781.49
Check Total:						13,781.49
28128	06/02/2025	0001 General Fund	Garnishments	FRANCHISE TAX BOARD		50.00
Check Total:						50.00
28129	06/02/2025	0001 General Fund	Garnishments	VEHICLE REGISTRATION		61.44
Check Total:						61.44
Report Total:						229,990.35

# Accounts Payable

## Checks for Approval

User: jmurillo  
 Printed: 6/5/2025 - 12:06 PM



*City of*  
**Atwater**  
*Community Pride City Wide*

750 Bellevue Road, Atwater CA 95301

Check Number	Check Date	Fund	Account Name	Vendor Name	Void	Amount
0	06/09/2025	6000 Water Enterprise Fund	Electronic Pmt Processing Exp	VANCO PAYMENT SOLUTIONS		40.15
0	06/09/2025	6010 Sewer Enterprise Fund	Cash with Fiscal Agent	THE BANK OF NEW YORK MELLON		61,666.67
0	06/09/2025	6010 Sewer Enterprise Fund	Cash with Fiscal Agent	THE BANK OF NEW YORK MELLON		178,007.29
0	06/09/2025	0001 General Fund	Electronic Pmt Processing Exp	CHASE MERCHANT SERVICES		44.95
0	06/09/2025	6010 Sewer Enterprise Fund	Cash with Fiscal Agent	THE BANK OF NEW YORK MELLON		33,147.40
0	06/09/2025	0001 General Fund	Electronic Pmt Processing Exp	CHASE MERCHANT SERVICES		1,157.89
0	06/09/2025	6020 Sanitation Enterprise Fund	Electronic Pmt Processing Exp	VANCO PAYMENT SOLUTIONS		40.14
0	06/09/2025	6010 Sewer Enterprise Fund	Cash with Fiscal Agent	THE BANK OF NEW YORK MELLON		97,916.67
0	06/09/2025	0001 General Fund	Electronic Pmt Processing Exp	CHASE MERCHANT SERVICES		44.95
0	06/09/2025	6010 Sewer Enterprise Fund	Electronic Pmt Processing Exp	VANCO PAYMENT SOLUTIONS		40.15
0	06/09/2025	0001 General Fund	Electronic Pmt Processing Exp	CHASE MERCHANT SERVICES		74.65
0	06/09/2025	0001 General Fund	Office Supplies	QUADIENT FINANCE USA INC		1,000.00
Check Total:						373,180.91
28130	06/09/2025	6000 Water Enterprise Fund	Office Supplies	ABS DIRECT INC		1,900.00
28130	06/09/2025	6010 Sewer Enterprise Fund	Professional Services	ABS DIRECT INC		747.97
28130	06/09/2025	6020 Sanitation Enterprise Fund	Professional Services	ABS DIRECT INC		747.97
28130	06/09/2025	6000 Water Enterprise Fund	Professional Services	ABS DIRECT INC		747.97
28130	06/09/2025	6020 Sanitation Enterprise Fund	Office Supplies	ABS DIRECT INC		1,900.00
28130	06/09/2025	6010 Sewer Enterprise Fund	Office Supplies	ABS DIRECT INC		1,900.00
Check Total:						7,943.91
28131	06/09/2025	7000 Internal Service Fund	Professional Services	ALLWAYS TOWING LLC		300.00
28131	06/09/2025	7000 Internal Service Fund	Professional Services	ALLWAYS TOWING LLC		450.00
Check Total:						750.00
28132	06/09/2025	7000 Internal Service Fund	Utilities	AMERIGAS - MODESTO		116.86
Check Total:						116.86
28133	06/09/2025	7000 Internal Service Fund	Special Departmental Expense	ASSOCIATES LOCK & SAFE SERVICE		21.11

Check Number	Check Date	Fund	Account Name	Vendor Name	Void	Amount
					Check Total:	21.11
28134	06/09/2025	6000 Water Enterprise Fund	Professional Services	ATWATER ELECTRIC		2,000.00
					Check Total:	2,000.00
28135	06/09/2025	7000 Internal Service Fund	Operations & Maintenance	ATWATER RADIATOR AND MUFFLER SHOP		26.10
					Check Total:	26.10
28136	06/09/2025	7000 Internal Service Fund	Professional Services	BARTON OVERHEAD DOOR		460.00
					Check Total:	460.00
28137	06/09/2025	7010 Employee Benefits Fund	Dental Insurance	BENEFIT COORDINATORS CORPORATION (BC		6,546.26
28137	06/09/2025	7010 Employee Benefits Fund	Dental Insurance	BENEFIT COORDINATORS CORPORATION (BC		3,553.53
28137	06/09/2025	7010 Employee Benefits Fund	Dental Insurance	BENEFIT COORDINATORS CORPORATION (BC		494.04
28137	06/09/2025	7010 Employee Benefits Fund	Dental Insurance	BENEFIT COORDINATORS CORPORATION (BC		3,354.97
28137	06/09/2025	7010 Employee Benefits Fund	Dental Insurance	BENEFIT COORDINATORS CORPORATION (BC		1,944.82
					Check Total:	15,893.62
28138	06/09/2025	7000 Internal Service Fund	Professional Services	BIC SECURITY		220.00
					Check Total:	220.00
28139	06/09/2025	1011 Gas Tax/Street Improvement	Special Departmental Expense	BIG CREEK LUMBER COMPANY		125.92
28139	06/09/2025	1011 Gas Tax/Street Improvement	Special Departmental Expense	BIG CREEK LUMBER COMPANY		17.60
28139	06/09/2025	6000 Water Enterprise Fund	Special Departmental Expense	BIG CREEK LUMBER COMPANY		107.22
28139	06/09/2025	6010 Sewer Enterprise Fund	Special Departmental Expense	BIG CREEK LUMBER COMPANY		29.44
28139	06/09/2025	6010 Sewer Enterprise Fund	Special Departmental Expense	BIG CREEK LUMBER COMPANY		25.42
28139	06/09/2025	6010 Sewer Enterprise Fund	Special Departmental Expense	BIG CREEK LUMBER COMPANY		22.42
28139	06/09/2025	0001 General Fund	Special Departmental Expense	BIG CREEK LUMBER COMPANY		24.01
28139	06/09/2025	6010 Sewer Enterprise Fund	Small Tools	BIG CREEK LUMBER COMPANY		38.78
28139	06/09/2025	1018 SB1-Road Maint & Rehab RMRA	Curb, Gutter, Sidewalk Project	BIG CREEK LUMBER COMPANY		310.30
28139	06/09/2025	6000 Water Enterprise Fund	Special Departmental Expense	BIG CREEK LUMBER COMPANY		121.96
28139	06/09/2025	1011 Gas Tax/Street Improvement	Special Departmental Expense	BIG CREEK LUMBER COMPANY		19.37
28139	06/09/2025	1011 Gas Tax/Street Improvement	Special Departmental Expense	BIG CREEK LUMBER COMPANY		31.87
28139	06/09/2025	6000 Water Enterprise Fund	Special Departmental Expense	BIG CREEK LUMBER COMPANY		19.37
28139	06/09/2025	0001 General Fund	Special Departmental Expense	BIG CREEK LUMBER COMPANY		166.45
28139	06/09/2025	1011 Gas Tax/Street Improvement	Special Departmental Expense	BIG CREEK LUMBER COMPANY		84.74
28139	06/09/2025	0001 General Fund	Special Departmental Expense	BIG CREEK LUMBER COMPANY		6.78
28139	06/09/2025	1011 Gas Tax/Street Improvement	Special Departmental Expense	BIG CREEK LUMBER COMPANY		19.37
28139	06/09/2025	0001 General Fund	Special Departmental Expense	BIG CREEK LUMBER COMPANY		36.18
28139	06/09/2025	6000 Water Enterprise Fund	Special Departmental Expense	BIG CREEK LUMBER COMPANY		98.75
28139	06/09/2025	7000 Internal Service Fund	Special Departmental Expense	BIG CREEK LUMBER COMPANY		15.06

Check Number	Check Date	Fund	Account Name	Vendor Name	Void	Amount
28139	06/09/2025	1011 Gas Tax/Street Improvement	Special Departmental Expense	BIG CREEK LUMBER COMPANY		19.37
28139	06/09/2025	1011 Gas Tax/Street Improvement	Special Departmental Expense	BIG CREEK LUMBER COMPANY		11.62
28139	06/09/2025	6000 Water Enterprise Fund	Special Departmental Expense	BIG CREEK LUMBER COMPANY		79.43
28139	06/09/2025	1011 Gas Tax/Street Improvement	Special Departmental Expense	BIG CREEK LUMBER COMPANY		29.06
28139	06/09/2025	6010 Sewer Enterprise Fund	Special Departmental Expense	BIG CREEK LUMBER COMPANY		30.13
28139	06/09/2025	6010 Sewer Enterprise Fund	Special Departmental Expense	BIG CREEK LUMBER COMPANY		36.84
Check Total:						1,527.46
28140	06/09/2025	6010 Sewer Enterprise Fund	Machinery & Equipment	BOGIES PUMP SYSTEMS		24,990.37
Check Total:						24,990.37
28141	06/09/2025	7000 Internal Service Fund	Special Departmental Expense	BRADY INDUSTRIES		1,323.06
28141	06/09/2025	7000 Internal Service Fund	Special Departmental Expense	BRADY INDUSTRIES		1,553.94
Check Total:						2,877.00
28142	06/09/2025	6007 1,2,3-TCP Fund	Professional Services	BSK ASSOCIATES		999.40
28142	06/09/2025	6000 Water Enterprise Fund	Professional Services	BSK ASSOCIATES		79.89
28142	06/09/2025	6000 Water Enterprise Fund	Professional Services	BSK ASSOCIATES		1,490.86
28142	06/09/2025	6000 Water Enterprise Fund	Professional Services	BSK ASSOCIATES		213.04
28142	06/09/2025	6000 Water Enterprise Fund	Professional Services	BSK ASSOCIATES		106.52
28142	06/09/2025	6000 Water Enterprise Fund	Professional Services	BSK ASSOCIATES		26.63
28142	06/09/2025	6007 1,2,3-TCP Fund	Professional Services	BSK ASSOCIATES		999.40
28142	06/09/2025	6007 1,2,3-TCP Fund	Professional Services	BSK ASSOCIATES		999.40
28142	06/09/2025	6000 Water Enterprise Fund	Professional Services	BSK ASSOCIATES		2,490.00
28142	06/09/2025	6000 Water Enterprise Fund	Professional Services	BSK ASSOCIATES		213.04
28142	06/09/2025	6007 1,2,3-TCP Fund	Professional Services	BSK ASSOCIATES		2,398.56
28142	06/09/2025	6000 Water Enterprise Fund	Professional Services	BSK ASSOCIATES		186.41
28142	06/09/2025	6000 Water Enterprise Fund	Professional Services	BSK ASSOCIATES		101.44
28142	06/09/2025	6000 Water Enterprise Fund	Professional Services	BSK ASSOCIATES		26.63
28142	06/09/2025	6000 Water Enterprise Fund	Professional Services	BSK ASSOCIATES		7,458.00
28142	06/09/2025	6000 Water Enterprise Fund	Professional Services	BSK ASSOCIATES		213.04
28142	06/09/2025	6000 Water Enterprise Fund	Professional Services	BSK ASSOCIATES		79.89
28142	06/09/2025	6000 Water Enterprise Fund	Professional Services	BSK ASSOCIATES		213.04
28142	06/09/2025	6000 Water Enterprise Fund	Professional Services	BSK ASSOCIATES		213.04
28142	06/09/2025	6000 Water Enterprise Fund	Professional Services	BSK ASSOCIATES		3,390.00
28142	06/09/2025	6007 1,2,3-TCP Fund	Professional Services	BSK ASSOCIATES		999.40
28142	06/09/2025	6000 Water Enterprise Fund	Professional Services	BSK ASSOCIATES		7,458.00
28142	06/09/2025	6000 Water Enterprise Fund	Professional Services	BSK ASSOCIATES		91.68
28142	06/09/2025	6000 Water Enterprise Fund	Professional Services	BSK ASSOCIATES		79.89
28142	06/09/2025	6000 Water Enterprise Fund	Professional Services	BSK ASSOCIATES		79.89
Check Total:						30,607.09

Check Number	Check Date	Fund	Account Name	Vendor Name	Void	Amount
28143	06/09/2025	7000 Internal Service Fund	Professional Services	BURTONS FIRE INC		2,100.00
28143	06/09/2025	7000 Internal Service Fund	Operations & Maintenance	BURTONS FIRE INC		1,511.52
28143	06/09/2025	7000 Internal Service Fund	Professional Services	BURTONS FIRE INC		6,650.00
28143	06/09/2025	7000 Internal Service Fund	Operations & Maintenance	BURTONS FIRE INC		132.97
28143	06/09/2025	7000 Internal Service Fund	Professional Services	BURTONS FIRE INC		4,068.75
28143	06/09/2025	7000 Internal Service Fund	Operations & Maintenance	BURTONS FIRE INC		17,344.74
28143	06/09/2025	7000 Internal Service Fund	Operations & Maintenance	BURTONS FIRE INC		1,110.54
				Check Total:		32,918.52
28144	06/09/2025	0001 General Fund	Coed Fall Softball	CAL FARM SERVICES		366.34
				Check Total:		366.34
28145	06/09/2025	6000 Water Enterprise Fund	Special Departmental Expense	CALIFORNIA INDUSTRIAL RUBBER COMPAN		20.00
				Check Total:		20.00
28146	06/09/2025	0001 General Fund	Men's Fall Softball	CALIFORNIA LANDSCAPE SUPPLY, INC.		556.99
28146	06/09/2025	0001 General Fund	Coed Fall Softball	CALIFORNIA LANDSCAPE SUPPLY, INC.		557.00
				Check Total:		1,113.99
28147	06/09/2025	7000 Internal Service Fund	Improvements Other Than Bldg	CENTRAL VALLEY AIRCONDITIONING INC		20,982.00
				Check Total:		20,982.00
28148	06/09/2025	6010 Sewer Enterprise Fund	Special Departmental Expense	CENTRAL VALLEY SALINITY COALITION INC		19,183.78
				Check Total:		19,183.78
28149	06/09/2025	0001 General Fund	Uniform & Clothing Expense	CINTAS CORP		39.14
28149	06/09/2025	1011 Gas Tax/Street Improvement	Small Tools	CINTAS CORP		7.33
28149	06/09/2025	0001 General Fund	Uniform & Clothing Expense	CINTAS CORP		39.14
28149	06/09/2025	1011 Gas Tax/Street Improvement	Uniform & Clothing Expense	CINTAS CORP		34.19
28149	06/09/2025	1011 Gas Tax/Street Improvement	Uniform & Clothing Expense	CINTAS CORP		34.19
28149	06/09/2025	7000 Internal Service Fund	Uniform & Clothing Expense	CINTAS CORP		7.33
28149	06/09/2025	7000 Internal Service Fund	Special Departmental Expense	CINTAS CORP		30.09
28149	06/09/2025	6000 Water Enterprise Fund	Uniform & Clothing Expense	CINTAS CORP		53.21
28149	06/09/2025	7000 Internal Service Fund	Special Departmental Expense	CINTAS CORP		30.09
28149	06/09/2025	7000 Internal Service Fund	Uniform & Clothing Expense	CINTAS CORP		7.33
28149	06/09/2025	6000 Water Enterprise Fund	Uniform & Clothing Expense	CINTAS CORP		53.21
28149	06/09/2025	1011 Gas Tax/Street Improvement	Uniform & Clothing Expense	CINTAS CORP		34.19
28149	06/09/2025	7000 Internal Service Fund	Uniform & Clothing Expense	CINTAS CORP		868.27
28149	06/09/2025	6010 Sewer Enterprise Fund	Uniform & Clothing Expense	CINTAS CORP		77.81
28149	06/09/2025	7000 Internal Service Fund	Uniform & Clothing Expense	CINTAS CORP		14.32
28149	06/09/2025	6010 Sewer Enterprise Fund	Uniform & Clothing Expense	CINTAS CORP		77.81

Check Number	Check Date	Fund	Account Name	Vendor Name	Void	Amount
28149	06/09/2025	7000 Internal Service Fund	Uniform & Clothing Expense	CINTAS CORP		14.32
28149	06/09/2025	7000 Internal Service Fund	Uniform & Clothing Expense	CINTAS CORP		14.32
28149	06/09/2025	6000 Water Enterprise Fund	Uniform & Clothing Expense	CINTAS CORP		53.21
28149	06/09/2025	6010 Sewer Enterprise Fund	Uniform & Clothing Expense	CINTAS CORP		77.81
28149	06/09/2025	7000 Internal Service Fund	Special Departmental Expense	CINTAS CORP		30.09
28149	06/09/2025	0001 General Fund	Uniform & Clothing Expense	CINTAS CORP		39.14
28149	06/09/2025	1011 Gas Tax/Street Improvement	Small Tools	CINTAS CORP		7.33
Check Total:						1,643.87
28150	06/09/2025	7000 Internal Service Fund	Utilities	COMCAST		13.10
28150	06/09/2025	7000 Internal Service Fund	Utilities	COMCAST		270.21
Check Total:						283.31
28151	06/09/2025	1011 Gas Tax/Street Improvement	Special Departmental Expense	CONSOLIDATED ELECTRICAL DISTRIBUTORS		52.44
Check Total:						52.44
28152	06/09/2025	0001 General Fund	Plan Check Fees	CSG CONSULTANTS, INC.		1,526.00
28152	06/09/2025	0001 General Fund	Inspection Fees	CSG CONSULTANTS, INC.		6,188.00
Check Total:						7,714.00
28153	06/09/2025	0001 General Fund	Professional Services	DATA TICKET INC		240.50
Check Total:						240.50
28154	06/09/2025	0001 General Fund	Various Classes	MARY ANN DAVIS		364.00
Check Total:						364.00
28155	06/09/2025	7000 Internal Service Fund	Professional Services	DELRAY TIRE		252.95
28155	06/09/2025	7000 Internal Service Fund	Operations & Maintenance	DELRAY TIRE		591.95
28155	06/09/2025	7000 Internal Service Fund	Operations & Maintenance	DELRAY TIRE		2,257.79
Check Total:						3,102.69
28156	06/09/2025	7000 Internal Service Fund	Special Departmental Expense	ELITE IRON FENCING		2,635.00
28156	06/09/2025	7000 Internal Service Fund	Professional Services	ELITE IRON FENCING		2,740.00
Check Total:						5,375.00
28157	06/09/2025	1018 SB1-Road Maint & Rehab RMRA	Curb, Gutter, Sidewalk Project	ELITE MAINTENANCE & TREE SERVICE		2,430.00
Check Total:						2,430.00
28158	06/09/2025	0001 General Fund	Men's Fall Softball	EWING IRRIGATION PRODUCTS INC.		298.81

Check Number	Check Date	Fund	Account Name	Vendor Name	Void	Amount
					Check Total:	298.81
28159	06/09/2025	7000 Internal Service Fund	Special Departmental Expense	FACILITY DESIGNS INC		316.00
					Check Total:	316.00
28160	06/09/2025	6000 Water Enterprise Fund	Special Departmental Expense	FERGUSON WATERWORKS		354.53
28160	06/09/2025	6000 Water Enterprise Fund	Special Departmental Expense	FERGUSON WATERWORKS		422.79
					Check Total:	777.32
28161	06/09/2025	0001 General Fund	Professional Services	MICHAEL FILLEBROWN		61.00
					Check Total:	61.00
28162	06/09/2025	6010 Sewer Enterprise Fund	Professional Services	FOSTER'S PUMPS, INC.		5,487.50
28162	06/09/2025	6010 Sewer Enterprise Fund	Special Departmental Expense	FOSTER'S PUMPS, INC.		1,031.03
					Check Total:	6,518.53
28163	06/09/2025	0001 General Fund	Training	FRESNO CITY COLLEGE		429.00
					Check Total:	429.00
28164	06/09/2025	6000 Water Enterprise Fund	Uniform & Clothing Expense	GCP WW HOLDCO LLC		194.84
28164	06/09/2025	6000 Water Enterprise Fund	Uniform & Clothing Expense	GCP WW HOLDCO LLC		184.01
					Check Total:	378.85
28165	06/09/2025	0007 Measure V Fund	Project Retention	GEORGE REED INC		-28,128.10
28165	06/09/2025	1010 ARPA-American Rescue Plan Act	Project Retention	GEORGE REED INC		-45,040.05
28165	06/09/2025	1010 ARPA-American Rescue Plan Act	Fruitland Ave Rd Improvements	GEORGE REED INC		900,801.00
28165	06/09/2025	0007 Measure V Fund	Fruitland Ave Rd Improvements	GEORGE REED INC		562,562.13
					Check Total:	1,390,194.98
28166	06/09/2025	0001 General Fund	Professional Services	GOLDEN STATE REALTY ASSOCIATES		122.00
					Check Total:	122.00
28167	06/09/2025	6000 Water Enterprise Fund	Special Departmental Expense	GRAINGER		326.86
28167	06/09/2025	6000 Water Enterprise Fund	Special Departmental Expense	GRAINGER		467.98
					Check Total:	794.84
28168	06/09/2025	1018 SB1-Road Maint & Rehab RMRA	Pavement Repairs	GRANITE CONSTRUCTION COMPANY		3,176.00

Check Number	Check Date	Fund	Account Name	Vendor Name	Void	Amount
Check Total:						3,176.00
28169	06/09/2025	7000 Internal Service Fund	Utilities	HOFFMAN SECURITY		1,042.90
28169	06/09/2025	7000 Internal Service Fund	Utilities	HOFFMAN SECURITY		57.00
28169	06/09/2025	7000 Internal Service Fund	Utilities	HOFFMAN SECURITY		176.85
Check Total:						1,276.75
28170	06/09/2025	7000 Internal Service Fund	Operations & Maintenance	HONDA KAWASAKI KTM OF MODESTO		9,050.43
28170	06/09/2025	7000 Internal Service Fund	Professional Services	HONDA KAWASAKI KTM OF MODESTO		1,980.00
28170	06/09/2025	7000 Internal Service Fund	Professional Services	HONDA KAWASAKI KTM OF MODESTO		-225.00
Check Total:						10,805.43
28171	06/09/2025	5010 Price Annexation LMA	Special Departmental Expense	HORIZON		1,570.92
28171	06/09/2025	0001 General Fund	Maint. Buildings & Grounds	HORIZON		373.33
28171	06/09/2025	0001 General Fund	Maint. Buildings & Grounds	HORIZON		1,296.86
28171	06/09/2025	1011 Gas Tax/Street Improvement	Special Departmental Expense	HORIZON		18.73
28171	06/09/2025	0001 General Fund	Special Departmental Expense	HORIZON		89.74
28171	06/09/2025	1011 Gas Tax/Street Improvement	Special Departmental Expense	HORIZON		45.47
Check Total:						3,395.05
28172	06/09/2025	0001 General Fund	Uniform & Clothing Expense	INSIDELINES GRAPHIX INC.		422.11
Check Total:						422.11
28173	06/09/2025	7000 Internal Service Fund	Professional Services	JANI TEK CLEANING SOLUTIONS		1,790.00
28173	06/09/2025	7000 Internal Service Fund	Professional Services	JANI TEK CLEANING SOLUTIONS		730.00
Check Total:						2,520.00
28174	06/09/2025	5031 Stone Creek LNDSCP	Professional Services	JOE'S LANDSCAPING & CONCRETE		827.69
28174	06/09/2025	5018 Cottage Gardens ST & LMA	Professional Services	JOE'S LANDSCAPING & CONCRETE		154.94
28174	06/09/2025	5010 Price Annexation LMA	Professional Services	JOE'S LANDSCAPING & CONCRETE		863.39
28174	06/09/2025	5022 Silva Ranch LNDSCP	Professional Services	JOE'S LANDSCAPING & CONCRETE		511.87
28174	06/09/2025	5010 Price Annexation LMA	Professional Services	JOE'S LANDSCAPING & CONCRETE		1,679.74
28174	06/09/2025	5044 Aspenwood Lndscp	Professional Services	JOE'S LANDSCAPING & CONCRETE		395.05
28174	06/09/2025	5027 Juniper Meadows LNDSCP	Professional Services	JOE'S LANDSCAPING & CONCRETE		138.72
28174	06/09/2025	5029 Camellia Meadows LNDSCP	Professional Services	JOE'S LANDSCAPING & CONCRETE		289.06
28174	06/09/2025	5014 Pajaro Dunes LMA	Professional Services	JOE'S LANDSCAPING & CONCRETE		231.19
28174	06/09/2025	5042 Meadow View LNDSCP	Professional Services	JOE'S LANDSCAPING & CONCRETE		356.12
28174	06/09/2025	5046 Applegate Ranch Lndscp	Professional Services	JOE'S LANDSCAPING & CONCRETE		430.75
28174	06/09/2025	5016 Redwood Estates LMA	Professional Services	JOE'S LANDSCAPING & CONCRETE		232.49
28174	06/09/2025	5010 Price Annexation LMA	Professional Services	JOE'S LANDSCAPING & CONCRETE		1,354.16
28174	06/09/2025	5024 Mello Ranch LNDSCP	Professional Services	JOE'S LANDSCAPING & CONCRETE		382.08

Check Number	Check Date	Fund	Account Name	Vendor Name	Void	Amount
28174	06/09/2025	5037 Atwater South LNDSCP	Professional Services	JOE'S LANDSCAPING & CONCRETE		1,084.18
28174	06/09/2025	5010 Price Annexation LMA	Professional Services	JOE'S LANDSCAPING & CONCRETE		236.95
28174	06/09/2025	5012 Sandlewood Square LMA	Professional Services	JOE'S LANDSCAPING & CONCRETE		376.67
28174	06/09/2025	5035 Bell Crossing LNDSCP	Professional Services	JOE'S LANDSCAPING & CONCRETE		232.81
28174	06/09/2025	5040 Mello Ranch 2 LNDSCP	Professional Services	JOE'S LANDSCAPING & CONCRETE		592.99
Check Total:						10,370.85
28175	06/09/2025	7000 Internal Service Fund	Special Departmental Expense	JOHNSTONE SUPPLY		149.26
28175	06/09/2025	7000 Internal Service Fund	Special Departmental Expense	JOHNSTONE SUPPLY		93.79
28175	06/09/2025	6010 Sewer Enterprise Fund	Special Departmental Expense	JOHNSTONE SUPPLY		139.74
Check Total:						382.79
28176	06/09/2025	7000 Internal Service Fund	Professional Services	JORGENSEN COMPANY		230.03
28176	06/09/2025	7000 Internal Service Fund	Professional Services	JORGENSEN COMPANY		310.78
Check Total:						540.81
28177	06/09/2025	6000 Water Enterprise Fund	Special Departmental Expense	KELLOGG SUPPLY		6.14
28177	06/09/2025	7000 Internal Service Fund	Operations & Maintenance	KELLOGG SUPPLY		70.35
28177	06/09/2025	6010 Sewer Enterprise Fund	Special Departmental Expense	KELLOGG SUPPLY		16.19
Check Total:						92.68
28178	06/09/2025	7000 Internal Service Fund	Operations & Maintenance	KEYES TRUCK CENTER		531.61
Check Total:						531.61
28179	06/09/2025	6001 Water Fund Capital Replacement	Installation-New Water Meters	LAWRENCE BACKHOE SERVICE INC		198,730.00
28179	06/09/2025	6001 Water Fund Capital Replacement	Project Retention	LAWRENCE BACKHOE SERVICE INC		-9,936.50
Check Total:						188,793.50
28180	06/09/2025	7000 Internal Service Fund	Operations & Maintenance	LAWSON PRODUCTS		91.58
Check Total:						91.58
28181	06/09/2025	0001 General Fund	Special Departmental Expense	LN CURTIS & SONS		2,961.58
Check Total:						2,961.58
28182	06/09/2025	0001 General Fund	Special Departmental Expense	LOPES SEPTIC & PUMPING		150.00
28182	06/09/2025	0001 General Fund	Special Departmental Expense	LOPES SEPTIC & PUMPING		150.00
Check Total:						300.00
28183	06/09/2025	0010 Measure V Regional Fund	Buhach Widening	MARK THOMAS & COMPANY, INC		3,841.00

Check Number	Check Date	Fund	Account Name	Vendor Name	Void	Amount
28183	06/09/2025	0010 Measure V Regional Fund	Buhach Widening	MARK THOMAS & COMPANY, INC		20,679.00
				Check Total:		24,520.00
28184	06/09/2025	0001 General Fund	Women's Volleyball	MERCED AREA SPORTS OFFICIALS, INC		300.00
28184	06/09/2025	0001 General Fund	Coed Volleyball	MERCED AREA SPORTS OFFICIALS, INC		776.00
				Check Total:		1,076.00
28185	06/09/2025	6000 Water Enterprise Fund	Professional Services	MERCED IRRIGATION DISTRICT		88.80
				Check Total:		88.80
28186	06/09/2025	7000 Internal Service Fund	Professional Services	MERCED TRUCK & TRAILER INC.		400.00
28186	06/09/2025	7000 Internal Service Fund	Professional Services	MERCED TRUCK & TRAILER INC.		400.00
28186	06/09/2025	7000 Internal Service Fund	Professional Services	MERCED TRUCK & TRAILER INC.		400.00
				Check Total:		1,200.00
28187	06/09/2025	0001 General Fund	Training	NIKKI MULLIGAN		57.56
				Check Total:		57.56
28188	06/09/2025	0001 General Fund	Professional Services	MUNISERVICES		129.60
28188	06/09/2025	0001 General Fund	Professional Services	MUNISERVICES		1,294.88
28188	06/09/2025	0001 General Fund	Professional Services	MUNISERVICES		500.00
28188	06/09/2025	0001 General Fund	Professional Services	MUNISERVICES		407.96
28188	06/09/2025	0001 General Fund	Professional Services	MUNISERVICES		7,561.35
				Check Total:		9,893.79
28189	06/09/2025	6010 Sewer Enterprise Fund	Special Departmental Expense	NAPA AUTO PARTS		5.07
28189	06/09/2025	7000 Internal Service Fund	Operations & Maintenance	NAPA AUTO PARTS		324.75
28189	06/09/2025	7000 Internal Service Fund	Operations & Maintenance	NAPA AUTO PARTS		6.47
28189	06/09/2025	0001 General Fund	Special Departmental Expense	NAPA AUTO PARTS		2,890.28
28189	06/09/2025	0001 General Fund	Special Departmental Expense	NAPA AUTO PARTS		-4.45
				Check Total:		3,222.12
28190	06/09/2025	0001 General Fund	Travel/Conferences/Meetings	MIKE NELSON		123.78
				Check Total:		123.78
28191	06/09/2025	0001 General Fund	Travel/Conferences/Meetings	WILLIAM NOVETZKE		150.44
				Check Total:		150.44
28192	06/09/2025	7000 Internal Service Fund	Operations & Maintenance	O'REILLY AUTO PARTS		191.28

Check Number	Check Date	Fund	Account Name	Vendor Name	Void	Amount
28192	06/09/2025	7000 Internal Service Fund	Operations & Maintenance	O'REILLY AUTO PARTS		45.66
28192	06/09/2025	7000 Internal Service Fund	Operations & Maintenance	O'REILLY AUTO PARTS		315.74
28192	06/09/2025	6010 Sewer Enterprise Fund	Special Departmental Expense	O'REILLY AUTO PARTS		41.29
28192	06/09/2025	7000 Internal Service Fund	Operations & Maintenance	O'REILLY AUTO PARTS		283.26
28192	06/09/2025	7000 Internal Service Fund	Operations & Maintenance	O'REILLY AUTO PARTS		161.19
28192	06/09/2025	7000 Internal Service Fund	Operations & Maintenance	O'REILLY AUTO PARTS		201.20
28192	06/09/2025	6010 Sewer Enterprise Fund	Special Departmental Expense	O'REILLY AUTO PARTS		76.09
28192	06/09/2025	7000 Internal Service Fund	Operations & Maintenance	O'REILLY AUTO PARTS		91.98
28192	06/09/2025	7000 Internal Service Fund	Operations & Maintenance	O'REILLY AUTO PARTS		3.09
28192	06/09/2025	1011 Gas Tax/Street Improvement	Special Departmental Expense	O'REILLY AUTO PARTS		38.05
28192	06/09/2025	0001 General Fund	Special Departmental Expense	O'REILLY AUTO PARTS		33.68
28192	06/09/2025	7000 Internal Service Fund	Operations & Maintenance	O'REILLY AUTO PARTS		102.05
28192	06/09/2025	7000 Internal Service Fund	Operations & Maintenance	O'REILLY AUTO PARTS		103.94
28192	06/09/2025	7000 Internal Service Fund	Small Tools	O'REILLY AUTO PARTS		173.99
28192	06/09/2025	7000 Internal Service Fund	Operations & Maintenance	O'REILLY AUTO PARTS		47.26
28192	06/09/2025	7000 Internal Service Fund	Operations & Maintenance	O'REILLY AUTO PARTS		17.26
28192	06/09/2025	7000 Internal Service Fund	Operations & Maintenance	O'REILLY AUTO PARTS		223.98
28192	06/09/2025	0001 General Fund	Special Departmental Expense	O'REILLY AUTO PARTS		16.28
28192	06/09/2025	6000 Water Enterprise Fund	Special Departmental Expense	O'REILLY AUTO PARTS		31.29
Check Total:						2,198.56
28193	06/09/2025	7000 Internal Service Fund	Operations & Maintenance	PAPE MACHINERY INC		423.81
Check Total:						423.81
28194	06/09/2025	0001 General Fund	Training	SAM PARKS		43.21
Check Total:						43.21
28195	06/09/2025	6000 Water Enterprise Fund	Professional Services	PRECISION CIVIL ENGINEERING, INC.		1,692.50
28195	06/09/2025	1017 RSTP-Regional Surf Transp Prog	Ace Train Platform	PRECISION CIVIL ENGINEERING, INC.		855.00
28195	06/09/2025	1020 Parks and Recreation Fund	Osborn Park Renovation	PRECISION CIVIL ENGINEERING, INC.		1,357.50
28195	06/09/2025	1017 RSTP-Regional Surf Transp Prog	Ace Train Platform	PRECISION CIVIL ENGINEERING, INC.		487.50
28195	06/09/2025	6000 Water Enterprise Fund	Professional Services	PRECISION CIVIL ENGINEERING, INC.		1,803.75
Check Total:						6,196.25
28196	06/09/2025	0001 General Fund	Special Departmental Expense	PRESTON'S LOCK & KEY		8.70
Check Total:						8.70
28197	06/09/2025	6001 Water Fund Capital Replacement	Canal Creek Utility Crossing	PROVOST & PRITCHARD CONSULTING GROU		1,437.29
28197	06/09/2025	6010 Sewer Enterprise Fund	Canal Creek Utility Crossing	PROVOST & PRITCHARD CONSULTING GROU		1,437.28
28197	06/09/2025	6001 Water Fund Capital Replacement	Well #20A Rehab	PROVOST & PRITCHARD CONSULTING GROU		372.60

Check Number	Check Date	Fund	Account Name	Vendor Name	Void	Amount
					Check Total:	3,247.17
28198	06/09/2025	6010 Sewer Enterprise Fund	Castle Sewer Interceptor	QUAD KNOFF		656.70
					Check Total:	656.70
28199	06/09/2025	6010 Sewer Enterprise Fund	Professional Services	RAFTELIS FINANCIAL		1,103.75
28199	06/09/2025	6000 Water Enterprise Fund	Professional Services	RAFTELIS FINANCIAL		1,103.75
					Check Total:	2,207.50
28200	06/09/2025	7000 Internal Service Fund	Operations & Maintenance	RAZZARI DODGE CHRYSLER JEEP RAM		120.37
28200	06/09/2025	7000 Internal Service Fund	Operations & Maintenance	RAZZARI DODGE CHRYSLER JEEP RAM		26.30
28200	06/09/2025	7000 Internal Service Fund	Professional Services	RAZZARI DODGE CHRYSLER JEEP RAM		787.50
28200	06/09/2025	7000 Internal Service Fund	Operations & Maintenance	RAZZARI DODGE CHRYSLER JEEP RAM		1,034.87
					Check Total:	1,969.04
28201	06/09/2025	3065 Low&Mod Inc Housing Asset Func	Professional Services	RSG INC		200.00
					Check Total:	200.00
28202	06/09/2025	1011 Gas Tax/Street Improvement	Special Departmental Expense	SAFE-T-LITE		140.57
28202	06/09/2025	1011 Gas Tax/Street Improvement	Special Departmental Expense	SAFE-T-LITE		29.54
28202	06/09/2025	1011 Gas Tax/Street Improvement	Special Departmental Expense	SAFE-T-LITE		-53.23
28202	06/09/2025	6010 Sewer Enterprise Fund	Special Departmental Expense	SAFE-T-LITE		216.90
					Check Total:	333.78
28203	06/09/2025	7000 Internal Service Fund	Professional Services	SAN JOAQUIN VALLEY AIR POLLUTION CON.		143.00
					Check Total:	143.00
28204	06/09/2025	0001 General Fund	Men's Fall Softball	SHERWIN-WILLIAMS CO.		207.03
					Check Total:	207.03
28205	06/09/2025	6010 Sewer Enterprise Fund	Utilities	SIEMENS FINANCIAL SERVICES, INC.		20,576.89
					Check Total:	20,576.89
28206	06/09/2025	1018 SB1-Road Maint & Rehab RMRA	Curb, Gutter, Sidewalk Project	SIERRA MATERIALS & TRUCKING COMPANY		1,143.55
					Check Total:	1,143.55
28207	06/09/2025	0001 General Fund	Uniform & Clothing Expense	DAYTON SNYDER		26.25

Check Number	Check Date	Fund	Account Name	Vendor Name	Void	Amount
					Check Total:	26.25
28208	06/09/2025	0001 General Fund	Special Departmental Expense	STAPLES		78.41
					Check Total:	78.41
28209	06/09/2025	0001 General Fund	Professional Services	STATE PRO BUILDERS INC.		4,500.00
					Check Total:	4,500.00
28210	06/09/2025	0001 General Fund	Professional Services	STERICYCLE INC		41.42
					Check Total:	41.42
28211	06/09/2025	6010 Sewer Enterprise Fund	Small Tools	SUNBELT RENTALS INC		2,076.94
					Check Total:	2,076.94
28212	06/09/2025	6000 Water Enterprise Fund	Special Departmental Expense	SUPERIOR POOL PRODUCTS LLC		494.49
28212	06/09/2025	6000 Water Enterprise Fund	Special Departmental Expense	SUPERIOR POOL PRODUCTS LLC		1,578.51
28212	06/09/2025	6000 Water Enterprise Fund	Special Departmental Expense	SUPERIOR POOL PRODUCTS LLC		1,026.97
28212	06/09/2025	6000 Water Enterprise Fund	Special Departmental Expense	SUPERIOR POOL PRODUCTS LLC		792.98
28212	06/09/2025	6000 Water Enterprise Fund	Special Departmental Expense	SUPERIOR POOL PRODUCTS LLC		1,157.39
28212	06/09/2025	6000 Water Enterprise Fund	Special Departmental Expense	SUPERIOR POOL PRODUCTS LLC		1,079.08
					Check Total:	6,129.42
28213	06/09/2025	0001 General Fund	Community Center Deposits	CHANDA TATE		210.00
					Check Total:	210.00
28214	06/09/2025	7030 Information Technology Fund	Special Departmental Expense	TEXT MY GOV		11,050.00
					Check Total:	11,050.00
28215	06/09/2025	1011 Gas Tax/Street Improvement	Special Departmental Expense	THE SIGN GUYS		402.38
					Check Total:	402.38
28216	06/09/2025	7000 Internal Service Fund	Utilities	TRIPP SECURITY SYSTEMS		33.00
					Check Total:	33.00
28217	06/09/2025	0001 General Fund	Plan Check Fees	TRUE NORTH COMPLIANCE SERVICES INC		6,125.00
					Check Total:	6,125.00
28218	06/09/2025	7000 Internal Service Fund	Operations & Maintenance	TURF STAR INC		70.89

Check Number	Check Date	Fund	Account Name	Vendor Name	Void	Amount
					Check Total:	70.89
28219	06/09/2025	7000 Internal Service Fund	Special Departmental Expense	ULINE		202.53
					Check Total:	202.53
28220	06/09/2025	7000 Internal Service Fund	Operations & Maintenance	VAN DE POL		14,340.55
28220	06/09/2025	7000 Internal Service Fund	Operations & Maintenance	VAN DE POL		12,396.41
28220	06/09/2025	7000 Internal Service Fund	Operations & Maintenance	VAN DE POL		256.60
					Check Total:	26,993.56
28221	06/09/2025	7010 Employee Benefits Fund	Vision Insurance	VISION SERVICE PLAN (CA)		26.37
28221	06/09/2025	7010 Employee Benefits Fund	Vision Insurance	VISION SERVICE PLAN (CA)		1,133.91
					Check Total:	1,160.28
28222	06/09/2025	0001 General Fund	Community Center Deposits	KISSY WARD		210.00
					Check Total:	210.00
28223	06/09/2025	0001 General Fund	Maint. Buildings & Grounds	WARD ENTERPRISES		114.02
28223	06/09/2025	0001 General Fund	Maint. Buildings & Grounds	WARD ENTERPRISES		141.21
					Check Total:	255.23
28224	06/09/2025	6000 Water Enterprise Fund	Special Departmental Expense	WATERFORD IRRIGATION SUPPLY, INC		20.63
28224	06/09/2025	6000 Water Enterprise Fund	Special Departmental Expense	WATERFORD IRRIGATION SUPPLY, INC		195.19
28224	06/09/2025	6000 Water Enterprise Fund	Special Departmental Expense	WATERFORD IRRIGATION SUPPLY, INC		27.01
					Check Total:	242.83
28225	06/09/2025	6000 Water Enterprise Fund	Special Departmental Expense	WINTON HARDWARE		10.76
28225	06/09/2025	0001 General Fund	Special Departmental Expense	WINTON HARDWARE		26.23
28225	06/09/2025	6010 Sewer Enterprise Fund	Special Departmental Expense	WINTON HARDWARE		68.58
28225	06/09/2025	6010 Sewer Enterprise Fund	Uniform & Clothing Expense	WINTON HARDWARE		37.49
					Check Total:	143.06
28226	06/09/2025	0001 General Fund	Women's Volleyball	WOODING CUSTOM GRAPHICS		146.14
28226	06/09/2025	0001 General Fund	Coed Volleyball	WOODING CUSTOM GRAPHICS		276.04
					Check Total:	422.18
28227	06/09/2025	0001 General Fund	Special Departmental Expense	WORK WELLNESS		581.00

Check Number	Check Date	Fund	Account Name	Vendor Name	Void	Amount
						Check Total: 581.00
						Report Total: 2,322,799.00



## CITY COUNCIL AGENDA REPORT

### CITY COUNCIL

Mike Nelson, Mayor  
Danny Ambriz                      Brian Raymond  
John Cale                              Kalisa Rochester

**MEETING DATE:** June 9, 2025  
**TO:** Mayor and City Council  
**FROM:** Anna Nicholas, Finance Director  
**PREPARED BY:** Anna Nicholas, Finance Director  
**SUBJECT:** **Approval of the Statement of Investment Policy for the 2025-26 Fiscal Year and Delegating Authority to the City Treasurer to Invest Funds in Accordance with the Statement of Investment Policy (Finance Director Nicholas)**

### **RECOMMENDED COUNCIL ACTION**

Adoption of Resolution No. 3536-25 approving the Statement of Investment Policy for Fiscal Year 2025-26 and delegating authority to the City Treasurer to invest funds in accordance with the Statement of Investment Policy.

#### **I. BACKGROUND/ANALYSIS:**

Government Code Section, 53600 et seq. contains the statutes governing the investment of public funds. Annually, the City's Statement of Investment Policy is reviewed and updated for compliance with Government code Section, 53600 et seq.

The goal of the Statement of Investment Policy presented to Council for adoption for fiscal year 2025-26 remains consistent with past fiscal years, which is to invest public funds in a manner which will provide maximum security, meet daily cash flow demands of the City, and provide the highest investment return while conforming to all California Laws pertaining to the investment of public funds.

In collaboration with the City of Atwater's investment advisor, Chandler Asset Management, finance staff recently reviewed the City's investment policy to verify if any revisions were needed in conjunction with California Government Code (Code) sections that govern the investment of public funds. Staff also reviewed the policy to ensure inclusion of the latest best practices from recognized industry groups such as Government Finance Officers Association (GFOA), California Society of Municipal Finance Officers (CSMFO) and California Municipal Treasurers Association (CMTA).

There are no recommended changes in policy content from the current fiscal year investment policy to the upcoming fiscal year investment policy. The only change in the policy attached referred to as Exhibit "A" is the update of the fiscal year from 2024-2025 to 2025-2026.

#### **II. FISCAL IMPACTS:**

While there is no direct fiscal impact with approval of this item, there is potential fiscal impact dependent on the type and length of the allowed investment. Remaining in compliance with Government Code Section 53600 *et seq.* is imperative to managing risk associated with noncompliance. Through annual review, update and approval, the investment policy remains in compliance with Government Code Section 53600 *et seq.* This item has been reviewed by the Finance Department.

**III. LEGAL REVIEW:**

This item has been reviewed by the City Attorney's Office.

**IV. EXISTING POLICY:**

Resolution No. 3464-24 is the most current adopted Statement of Investment Policy which covers Fiscal Year 2024-25. Approving Resolution XXXX-25 will bring into effect the Statement of Investment Policy for the Fiscal Year of 2025-26. This item also contributes toward the City Council's goal of ensuring financial solvency by complying with Government Code 53600 *et seq.*

**V. ALTERNATIVES:**

The City Council could choose not to adopt Resolution No. 3526-25 approving the Statement of Investment Policy for Fiscal Year 2025-26.

**VI. INTERDEPARTMENTAL COORDINATION:**

While Interdepartmental Coordination is not necessary for completion of this Resolution to approve the FY 2024-25 Statement of Investment Policy, it is fully expected all municipal departments will comply with the Statement of Investment Policy.

**VII. PUBLIC PARTICIPATION:**

The public will have an opportunity to provide comments on this item prior to City Council action.

**VIII. ENVIRONMENTAL REVIEW:**

This item is not a project under the California Environmental Quality Act (CEQA) as this activity does not cause either direct physical change in the environment, or a reasonably foreseeable indirect physical change in the environment, pursuant to Public Resources Code Section 21065.

**IX. STEPS FOLLOWING APPROVAL:**

Following approval and adoption of Resolution 3536-25, the City Clerk will post the FY 2025-26 Statement of Investment Policy to the City's website. The City will implement the FY 2025-26 Statement of Investment Policy for all applicable activities.

Submitted by:



---

Anna Nicholas, Finance Director

Approved by:



---

Chris Hoem, City Manager

Attachments:

1. XXXX Reso Adopt Stmt of Investment Policy FY 25-26
2. FY 25-26 Atwater Investment Policy-FINAL



**CITY COUNCIL  
OF THE  
CITY OF ATWATER**

**RESOLUTION NO. XXXX-25**

**A RESOLUTION OF THE CITY COUNCIL OF THE  
CITY OF ATWATER APPROVING THE  
STATEMENT OF INVESTMENT POLICY FOR THE  
2025-2026 FISCAL YEAR AND DELEGATING  
AUTHORITY TO THE CITY TREASURER TO  
INVEST FUNDS IN ACCORDANCE WITH THE  
STATEMENT OF INVESTMENT POLICY**

**WHEREAS**, the City Council has reviewed a proposed annual Statement of Investment Policy providing guidelines for the investment of City funds pursuant to Government Code Sections 53600 *et seq.*; and

**WHEREAS**, consistent with Government Code Section 53607, the City Council may annually delegate authority to the City Treasurer to make investments on behalf of the City.

**NOW, THEREFORE, BE IT RESOLVED**, by the City Council of the City of Atwater that the Statement of Investment Policy attached as **Exhibit "A"** is hereby approved.

**BE IT FURTHER RESOLVED**, that the City Council does hereby delegate authority to the City Treasurer to invest funds in accordance with the City's Statement of Investment Policy for the 2025-2026 fiscal year.

The foregoing resolution is hereby adopted this 9th day of June 2025.

**AYES:  
NOES:  
ABSENT:**

**APPROVED:**

\_\_\_\_\_  
**MIKE NELSON, MAYOR**

**ATTEST:**

\_\_\_\_\_  
**KORY J. BILLINGS, CITY CLERK**

CITY OF ATWATER  
STATEMENT OF INVESTMENT POLICY  
Fiscal Year 2025-2026

**1. Purpose**

This statement is intended to provide a guideline for the prudent investment of operating funds and restricted monies and to outline a policy for maximizing the efficiency of the cash management system for the City of Atwater. Ultimate investment goals include the enhancement of economic status and the protection of pooled cash investments. This investment policy was endorsed and adopted by the City Council of the City of Atwater, is effective as of the 10th day of June, 2025, and replaces any previous version.

**2. Policy**

It is the policy of the City of Atwater to invest public funds in a manner which will provide maximum security, meet the daily cash flow demands of the City, and provide highest investment return while conforming to all California laws set forth in the State Government Code, Sections 53600 *et seq.*, and local statutes governing the investment of public funds.

**3. Scope**

This Investment Policy applies to all funds and investment activities under the direct authority of the City of Atwater, including that of the Successor Agency to the Atwater Redevelopment Agency. This policy does not cover any funds held by fiscal agents in connection with the issuance of any debt by the City. Such funds shall be invested in accordance with the bond documents and trust indentures.

Pooling of funds: Except for cash in certain restricted and special funds, the Agency will consolidate cash and reserve balances from all funds to maximize investment earnings and to increase efficiencies with regard to investment pricing, safekeeping and administration. Investment income will be allocated to the various funds based on their respective participation and in accordance with generally accepted accounting principles.

**4. Prudence**

Pursuant to California Government Code , Section 53600.3, all persons authorized to make investment decisions on behalf of the City are trustees and therefore fiduciaries subject to the prudent investor standard: "...all governing bodies of local agencies or persons authorized to make investment decisions on behalf of those local agencies investing public funds pursuant to this chapter are trustees and therefore fiduciaries subject to the prudent investor standard." When investing, reinvesting, purchasing, acquiring, exchanging, selling, or managing public funds, a trustee shall act with care, skill, prudence, and diligence under the circumstances then prevailing, including, but not limited to, the general economic conditions and the anticipated needs of the agency, that a prudent person acting in a like capacity and familiarity with those matters would use in the conduct of funds of a like character and with like aims, to safeguard the principal and maintain the liquidity needs of the agency. Within the limitations of this section and considering individual investments as part of an overall strategy, investments may be acquired as authorized by law. Investment officials shall recognize that the investment portfolio is subject to public review and evaluation. The overall investment program shall be designed and managed with a degree of professionalism that is worthy of the public trust. Deviations from expectations of a security's credit or market risk should be reported to the governing body in a timely fashion and appropriate action should be taken to control adverse developments.

CITY OF ATWATER  
STATEMENT OF INVESTMENT POLICY  
Fiscal Year 2025-2026

**5. Objective**

The primary objectives in priority order, of the City of Atwater's investment activities shall be:

5.1 Safety: Safety of principal is the foremost objective of the investment program. Investments of the City of Atwater shall be undertaken in a manner that seeks to ensure that capital losses are avoided, whether from securities default, broker-dealer default, or erosion of market value. To attain this objective, diversification is required in order that potential losses on individual securities do not exceed the income generated from the remainder of the portfolio. The City may elect to sell a security prior to its maturity and record a capital gain or loss in order to improve the quality, liquidity or yield of the portfolio in response to market conditions or the City's risk preferences.

5.2 Liquidity: The City of Atwater's investment portfolio will remain sufficiently liquid to enable the City to meet all operating requirements, which might be reasonably anticipated.

5.3 Return on Investment: The City of Atwater's investment portfolio shall be designed with the objective of attaining a market rate of return throughout budgetary and economic cycles, taking into account the City's investment risk constraints and the cash flow characteristics of the portfolio.

**6. Risk Tolerance**

The City Council of the City of Atwater recognizes that investment risks can result from issuer default, market price changes or various technical complications leading to temporary illiquidity. Portfolio diversification is employed as a method to control risk. Investment managers are expected to display prudence in the selection of securities, as a way to minimize default risk. No individual investment transaction shall be undertaken, which jeopardizes the total capital position of the overall portfolio. The City Treasurer shall, concurrent with the annual review and approval of the City's Statement of Investment Policy, periodically recommend to the City Council guidelines and strategies to control risks of default, market price changes and liquidity.

**7. Delegation of Authority**

Management responsibility for the investment program is the responsibility of the City Council unless delegated by City Council action to the City Treasurer. Investment of City of Atwater funds shall be conducted within the constraints of this Investment Policy. The conduct of the City's day-to-day banking and investment activities shall be the responsibility of the Finance Director, Finance Operations Manager and/or City Manager of the City of Atwater. The Finance Director, Finance Operations Manager and/or City Manager must conform to the signature requirements on all City accounts and cannot conduct banking and investing business without the proper signatures.

The City may engage the services of one or more external investment advisers, who are registered under the Investment Advisers Act of 1940, to assist in the management of the City's investment portfolio in a manner consistent with the City's objectives. External investment advisers may be granted discretion to purchase and sell investment securities in accordance with this investment policy.

The City's overall investment program shall be designed and managed with a degree of professionalism that is worthy of the public trust. The City recognizes that in a diversified portfolio,

CITY OF ATWATER  
STATEMENT OF INVESTMENT POLICY  
Fiscal Year 2025-2026

occasional measured losses may be inevitable and must be considered within the context of the overall portfolio's return and the cash flow requirements of the City.

**8. Ethics and Conflicts of Interest**

Officers and employees involved in the investment process shall refrain from personal business activity that could conflict with proper execution of the investment program, or which could impair their ability to make impartial investment decisions. Employees and investment officials shall disclose to the City Manager any material financial interests in financial institutions that conduct business within the jurisdiction, and they shall further disclose any large personal financial/investment positions that could be related to the performance of the City of Atwater's portfolio. Employees and officers shall subordinate their personal investment transactions to those of the City's, particularly with regard to the time of purchases and sales.

All participants in the investment process are required to comply with terms of the Political Reform Act, Fair Political Practices Commission Regulations promulgated thereunder (2 C.C.R. §§ 18110 through 18998), the City's Conflict of Interest Policy, including, without limitation, filing of Form 700, notification and recusal obligations, and Government Code section 1090 prohibitions.

**9. Authorized Financial Dealers and Institutions**

To the extent practicable, the Treasurer shall endeavor to complete investment transactions using a competitive bid process whenever possible. The City's Treasurer will determine which financial institutions are authorized to provide investment services to the City. It shall be the City's policy to purchase securities only from authorized institutions and firms.

The Treasurer shall maintain procedures for establishing a list of authorized broker/dealers and financial institutions that are approved for investment purposes that are selected through a process of due diligence as determined by the City. Due inquiry shall determine whether such authorized broker/dealers, and the individuals covering the City are reputable and trustworthy, knowledgeable and experienced in Public City investing and able to meet all of their financial obligations. These institutions may include "primary" dealers or regional dealers that qualify under Securities and Exchange Commission (SEC) Rule 15c3-1 (uniform net capital rule).

In accordance with Gov. Code Section 53601.5, the City is permitted to purchase investments from the following institutions:

- Institutions licensed by the state as a broker-dealer.
- Institutions that are members of a federally regulated securities exchange.
- A brokerage firm designated as a primary government dealer by the Federal Reserve bank.
- Nationally or state-chartered banks.
- A State Association or a Federal Association
- Direct issuers of securities eligible for purchase.

Selection of financial institutions and broker/dealers authorized to engage in transactions will be at the sole discretion of the City, except where the City utilizes an external investment adviser in which case the City may rely on the adviser for selection.

CITY OF ATWATER  
STATEMENT OF INVESTMENT POLICY  
Fiscal Year 2025-2026

All financial institutions which desire to become qualified bidders for investment transactions (and which are not dealing only with the investment adviser) must supply the Treasurer with audited financials and a statement certifying that the institution has reviewed the California Government Code, Section 53600 *et seq.* and the City's investment policy. The Treasurer will conduct an annual review of the financial condition and registrations of such qualified bidders.

Public deposits will be made only in qualified public depositories as established by State law. Deposits will be insured by the Federal Deposit Insurance Corporation, or, to the extent the amount exceeds the insured maximum, will be collateralized in accordance with State law.

Selection of broker/dealers used by an external investment adviser retained by the City will be at the sole discretion of the adviser. Where possible, transactions with broker/dealers shall be selected on a competitive basis and their bid or offering prices shall be recorded. If there is no other readily available competitive offering, best efforts will be made to document quotations for comparable or alternative securities. When purchasing original issue instrumentality securities, no competitive offerings will be required as all dealers in the selling group offer those securities at the same original issue price.

**10. Authorized Investments**

The City is governed by the California Government Code Sections 53600 *et seq.* Authorized investments of the City are detailed in Exhibit "A" which is made part of this investment policy.

**11. Investment Pools / Mutual Funds**

The Agency shall conduct a thorough investigation of any pool or mutual fund prior to making an investment, and on a continual basis thereafter. The Treasurer shall develop a questionnaire which will answer the following general questions:

- A description of eligible investment securities, and a written statement of investment policy and objectives.
- A description of interest calculations and how it is distributed, and how gains and losses are treated.
- A description of how the securities are safeguarded (including the settlement processes), and how often the securities are priced and the program audited.
- A description of who may invest in the program, how often, what size deposit and withdrawal are allowed.
- A schedule for receiving statements and portfolio listings.
- Are reserves, retained earnings, etc. utilized by the pool/fund?
- A fee schedule, and when and how is it assessed.
- Is the pool/fund eligible for bond proceeds and/or will it accept such proceeds?

CITY OF ATWATER  
STATEMENT OF INVESTMENT POLICY  
Fiscal Year 2025-2026

**12. Collateralization**

Collateralization will be required as indicated in Exhibit "A". Collateral will always be held by an independent third party with whom the City has a current custodial agreement. A clearly marked evidence of ownership (safekeeping receipt) must be supplied to the City and retained. The right of collateral substitution may be granted.

CERTIFICATES OF DEPOSIT (CDS). The City shall require any commercial bank or savings and loan association to deposit eligible securities with an agency of a depository approved by the State Banking Department to secure any uninsured portion of a Non-Negotiable Certificate of Deposit. The value of eligible securities as defined pursuant to California Government Code, Section 53651, pledged against a Certificate of Deposit shall be equal to 150% of the face value of the CD if the securities are classified as mortgages and 110% of the face value of the CD for all other classes of security.

COLLATERALIZATION OF BANK DEPOSITS. This is the process by which a bank or financial institution pledges securities, or other deposits for the purpose of securing repayment of deposited funds. The City shall require any bank or financial institution to comply with the collateralization criteria defined in California Government Code, Section 53651.

REPURCHASE AGREEMENTS. The City requires that Repurchase Agreements be collateralized only by securities authorized in accordance with California Government Code:

- The securities which collateralize the repurchase agreement shall be priced at Market Value, including any Accrued Interest plus a margin. The Market Value of the securities that underlie a repurchase agreement shall be valued at 102% or greater of the funds borrowed against those securities.
- Financial institutions shall mark the value of the collateral to market at least monthly and increase or decrease the collateral to satisfy the ratio requirement described above.
- The City shall receive monthly statements of collateral.

**13. Safekeeping and Custody**

All securities owned by the City, shall be held in safekeeping by the City's custodian bank or a third-party bank trust department, acting as agent for the City under the terms of a custody or trustee agreement executed by the bank and by the City. A monthly report will be received by the City from the custodian or third-party bank trust department listing all securities held in safekeeping with current market data and other information. All securities will be received and delivered using standard delivery-versus-payment (DVP) procedures. The only exceptions to the foregoing shall be depository accounts and securities purchases made with: (i) local government investment pools; (ii) time certificates of deposit, and, (iii) mutual funds and money market mutual funds, since these securities are not deliverable.

CITY OF ATWATER  
STATEMENT OF INVESTMENT POLICY  
Fiscal Year 2025-2026

**14. Risk Management and Diversification**

**MITIGATING CREDIT RISK IN THE PORTFOLIO**

Credit risk is the risk that a security or a portfolio will lose some or all its value due to a real or perceived change in the ability of the issuer to repay its debt. The City will mitigate credit risk by adopting the following strategies:

- Following the diversification requirements included in the “Authorized Investments” section of this policy.
- No more than 5% of the total portfolio may be deposited with or invested in securities issued by any single issuer unless otherwise specified in this policy.
- The City may elect to sell a security prior to its maturity and record a capital gain or loss in order to manage the quality, liquidity or yield of the portfolio in response to market conditions or City’s risk preferences.
- If a security owned by the City is downgraded to a level below the requirements of this policy, making the security ineligible for additional purchases, the following steps will be taken:
  - Any actions taken related to the downgrade by the investment manager will be communicated to the Treasurer in a timely manner.
  - If a decision is made to retain the security, the credit situation will be monitored and reported to the City Council.

**MITIGATING MARKET RISK IN THE PORTFOLIO**

Market risk is the risk that the portfolio value will fluctuate due to changes in the general level of interest rates. The City recognizes that, over time, longer-term portfolios have the potential to achieve higher returns. On the other hand, longer-term portfolios have higher volatility of return. The City will mitigate market risk by providing adequate liquidity for short-term cash needs, and by making longer-term investments only with funds that are not needed for current cash flow purposes.

The City further recognizes that certain types of securities, including variable rate securities, securities with principal paydowns prior to maturity, and securities with embedded options, will affect the market risk profile of the portfolio differently in different interest rate environments. The City, therefore, adopts the following strategies to control and mitigate its exposure to market risk:

CITY OF ATWATER  
STATEMENT OF INVESTMENT POLICY  
Fiscal Year 2025-2026

- The City will maintain a minimum of six months of budgeted operating expenditures in short-term investments to provide sufficient liquidity for expected disbursements.
- The maximum stated final maturity of individual securities in the portfolio will be five (5) years, except as otherwise stated in this policy.
  
- The duration of the portfolio will generally be approximately equal to the duration (typically, plus or minus 20%) of a Market Benchmark, an index selected by the City based on the City's investment objectives, constraints and risk tolerances.

**15. Maximum Maturities**

Unless matched to a specific cash flow, the City will not directly invest in securities maturing more than five years from the settlement date (See exceptions indicated in Exhibit "A").

**16. Internal Control**

The Treasurer shall establish a system of written internal controls which shall be reviewed by an independent auditor. This review will provide internal control by assuring compliance with policies and procedures. The controls shall be designed to prevent losses of public funds arising from fraud, employee error, misrepresentation of third parties, unanticipated changes in financial markets, or imprudent actions by employees and officers of the city. Controls deemed most important include: control of collusion, separation of duties, separation of transaction authority from accounting and recordkeeping, clear delegation of authority, specific limitations regarding securities losses and remedial action, written confirmation of telephone transactions, minimizing the number of authorized investment officials, documentation of transactions and strategies, and code of ethics standards.'

**17. Performance Standards**

The investment portfolio shall be designed to attain a market average rate of return through budgetary and economic cycles, taking into account the investment risk constraints and cash flow needs. The specific investment performance objective for the portfolio shall be to earn a total rate of return over a market cycle which is approximately equal to a market benchmark index. The current benchmark index for the portfolio is the ICE BofA 1-5 Yr US Treasury & Agency Index.

**18. Reporting**

The City Treasurer shall submit a monthly investment report to the City Council. This report will include all required elements of the monthly report as prescribed in California Government Code Section 53646. Pursuant to the adopted Investment Policy for the City of Atwater, this monthly shall include:

1. The type of investment, name of issuer, date of investment, date of maturity, rate of interest, asking price and par and dollar amount invested on all securities, investments, monies and/or deposits.
2. The weighted average maturity of the portfolio.
3. Transactions for the period
4. A description of the funds, investments and programs (including lending programs)

CITY OF ATWATER  
STATEMENT OF INVESTMENT POLICY  
Fiscal Year 2025-2026

managed by contracted parties (i.e. LAIF, investment pools, outside money managers and securities lending agents)

5. The market value as of the date of the report and the source of the valuation.
6. A statement of compliance with the Investment Policy or, if not in compliance, a statement of non-compliance and the manner in which the portfolio is not in compliance.
7. A statement of compliance with California Government Code Section 53646 from the City Treasurer certifying that sufficient investment liquidity and anticipated revenues are available to meet the City's budgeted expenditure requirement for the next six (6) months or an explanation as to why sufficient money shall, or may, not be available

**19. Review of the Investment Policy**

The City of Atwater's Statement of Investment Policy shall be reviewed and adopted at least annually within 120 days of the end of the fiscal year to ensure its consistency with the overall objectives of preservation of principal, liquidity and return, and its relevance to current law and financial and economic trends by City Council resolution. Any modifications made thereto must be approved by the City Council.

**20. External Auditor**

As a part of each year's financial audit of the City of Atwater, the external auditors shall review the Statement of Investment Policy and shall confirm that the City's investments are in compliance with that policy. Any issues noted will be reported to the City Council.

CITY OF ATWATER  
STATEMENT OF INVESTMENT POLICY  
Fiscal Year 2025-2026

ALLOWABLE INVESTMENTS AND ADDITIONAL INVESTMENT GUIDELINES

**A. INVESTMENTS**- Within the investments permitted by the Code, the Agency seeks to further restrict eligible investments to the guidelines listed below. In the event a discrepancy is found between this policy and the Code, the more restrictive parameters will take precedence. Percentage holding limits listed in this section apply at the time the security is purchased.

Any investment currently held at the time the policy is adopted which does not meet the new policy guidelines can be held until maturity and shall be exempt from the current policy. At the time of the investment's maturity or liquidation, such funds shall be reinvested only as provided in the current policy.

An appropriate risk level shall be maintained by primarily purchasing securities that are of high quality, liquid, and marketable. The portfolio shall be diversified by security type and institution to avoid incurring unreasonable and avoidable risks regarding specific security types or individual issuers.

**1. U.S. Treasury Securities (bills, notes and bonds)** are sold to finance gaps between the federal government's receipts and expenditures.

California Government Code Section 53601 Requirement: No limit specified:

City of Atwater Limitation:

- 1) Maximum maturity - five years
- 2) Maximum par value total size - None
- 3) Maximum par value per issue- None
- 4) Credit- Full faith and credit of the Federal Government

**2. U.S. Agency & Government Sponsored Enterprise Securities** are not direct obligations of the United States but rather are direct obligations of agencies of the federal government or government-sponsored enterprises. Securities issued by U.S. government agencies are backed by the full faith and credit of the U.S. government. They include the following agencies:

- Government National Mortgage Association (GNMA)
- Export-Import Bank (EXIMBANK)
- Small Business Administration (SBAs)
- Farmers Home Administration (FHA)
- General Services Administration (GSA)
- Maritime Administration

The federal government has sponsored the creation of, or the financial support of several corporations, also known as government-sponsored enterprises. None of these organizations carry the federal government guarantee.

They include the following agencies:

- Federal National Mortgage Association (FNMA)
- Federal Farm Credit Bank (FFCB)
- Federal Home Loan Bank (FHLB)

CITY OF ATWATER  
STATEMENT OF INVESTMENT POLICY  
Fiscal Year 2025-2026

ALLOWABLE INVESTMENTS AND ADDITIONAL INVESTMENT GUIDELINES

- Federal Home Loan Mortgage Corporation (FHLMC)
- Tennessee Valley Authority (TVA)

California Government Code Section 53601 Requirement: No limit specified.

City of Atwater Limitation:

- 1) Maximum maturity- five years
- 2) Maximum par value total size- no limitation
- 3) Maximum par value per issue-no limitation
- 4) The maximum percent of callable agency securities in the portfolio will be 20%.
- 5) Credit-Despite having no statutory limitation concerning this category, prudent investment practice necessitates constant analysis of the issuing agency. Although these issues have either the implicit or explicit guarantee of the federal government, market perception often limits the liquidity of these issues.

**3. Obligations of the State of California or any local agency within the state,** including bonds payable solely out of revenues from a revenue producing property owned, controlled or operated by the state or any local agency, or by a department, board, agency or authority of the state or any local agency.

California Government Code Section 53601 Requirement: No limit specified.

City of Atwater Limitation:

- 1) Maximum maturity- five years
- 2) Maximum par value total size- 30% of portfolio
- 3) Maximum par value per issue-5%
- 4) Credit- The Securities are rated in a rating category of "A" or its equivalent or better by at least one nationally recognized statistical rating organization ("NRSRO")

**4. Obligations (Municipal Securities) of any of the other 49 states in addition to California,** including bonds payable solely out of revenues from a revenue producing property owned, controlled or operated by the state or any local agency, or by a department, board, agency or authority of the state or any local agency.

California Government Code Section 53601 Requirement: No limit specified.

City of Atwater Limitation:

- 1) Maximum maturity- five years
- 2) Maximum par value total size- 30% of portfolio
- 3) Maximum par value per issue-5%
- 4) Credit- The Securities are rated in a rating category of "A" or its equivalent or better by at least one nationally recognized statistical rating organization ("NRSRO")

**5. Bankers Acceptances** are typically created from a letter of credit issued in a foreign trade transaction and are time drafts drawn on and accepted by a bank to pay a specified amount of money on a specified date.

CITY OF ATWATER  
STATEMENT OF INVESTMENT POLICY  
Fiscal Year 2025-2026

**ALLOWABLE INVESTMENTS AND ADDITIONAL INVESTMENT GUIDELINES**

California Government Code Section 53601 Requirement:

- 1) Purchases may not exceed 180 days.
- 2) Purchases are restricted to 40% of the agency's surplus money.
- 3) No more than 30% of the City's surplus money may be invested in the bankers' acceptances of any one commercial bank.
- 4) Include only those that are eligible for discounting with the Federal Reserve System.

City of Atwater Limitation:

- 1) Maximum maturity – 180 days
- 2) Maximum par value size 30% of portfolio
- 3) Maximum par value per institution - 5%
- 4) Credit - financial institutions that shall only include banks that have short-term credit ratings of A-1, P-1 or equivalent ratings from other recognized rating services.

**6. Certificates of Deposit**

a. Negotiable Certificats of Deposit (NCDs), issued by a nationally or state-chartered bank, a savings association or a federal association, a state or federal credit union, or by a federally licensed or state-licensed branch of a foreign ban:

California Government Code Section 53601(i) Requirement:

- 1) Maximum maturity - 5 years
- 2) Maximum par value total size - No more than 30% of the total portfolio may be invested in NCDs.

City of Atwater Limitation:

- 1) Maximum maturity - 5 years
- 2) Maximum par value total size - No more than 30% of the total portfolio may be invested in NCDs (combined with CDARS).
- 3) Maximum par value per institution - No more than 5% of the total portfolio may be invested in any single issuer.
- 4) Credit - The amount of the NCD insured up to the FDIC limit does not require any credit ratings. Any amount above the FDIC insured limit must be issued by institutions which have short-term debt obligations rated "A-1" or its equivalent or better by at least one NRSRO; or long-term obligations rated in a rating category of "A" or its equivalent or better by at least one NRSRO.

b. Federally Insured Time Deposits (Non-Negotiable Certificates of Deposit) in state or federally chartered banks, savings and loans, or credit unions.

California Government Code Section 53630 Requirement:

- 1) Maximum maturity - 5 years

City of Atwater Limitation:

- 1) Maximum maturity - 5 years
- 2) Maximum par value total size - No more 20% of the total portfolio will be invested in a combination of federally insured and collateralized time deposits.

CITY OF ATWATER  
STATEMENT OF INVESTMENT POLICY  
Fiscal Year 2025-2026

ALLOWABLE INVESTMENTS AND ADDITIONAL INVESTMENT GUIDELINES

3) Maximum par value per institution - The amount per institution is limited to the maximum covered under federal insurance.

c. Collateralized Time Deposits (Non-Negotiable Certificates of Deposit) in state or federally chartered banks, savings and loans, or credit unions in excess of insured amounts which are fully collateralized with securities in accordance with California law.

California Government Code Section 53630 Requirement:

1) Maximum maturity - 5 years

City of Atwater Limitation:

1) Maximum maturity - 5 years

2) Maximum par value total size - No more 20% of the total portfolio will be invested in a combination of federally insured and collateralized time deposits.

d. Placement Service Deposit:

California Government Code Section 53630 Requirement:

1) Maximum maturity - 5 years

2) Maximum par value total size - Under a provision sunsetting on January 1, 2026, no more than 50% of the portfolio may be invested in deposits through a placement service, including Certificates of Deposit, if the Agency is a city, district or local agency that does not pool money with other local agencies.

City of Atwater Limitation:

1) Maximum maturity - 5 years

2) Maximum par value total size No more than 30% of the total portfolio may be invested in a combination of Certificates of Deposit, including CDARS.

e. Collateralized Bank Deposits. The City's deposits with financial institutions will be collateralized with pledged securities per California Government Code, Section 53651. There are no limits on the dollar amount or percentage that the City may invest in collateralized bank deposits.

California Government Code Section 53630 Requirement:

3) Maximum maturity - 5 years

4) Maximum par value total size – No limit

City of Atwater Limitation:

1) Maximum maturity - 5 years

**7. Commercial Paper** are short-term unsecured promissory notes issued by various economic entities in the open market to finance certain short-term credit needs.

California Government Code Section 53601 Requirement:

1) Prime quality of the highest ranking or of the highest letter and numerical rating as provided for by nationally recognized statistical-rating organization.

2) Issuing corporation must be organized and operating within the United States.

3) Issuing corporation must have total assets in excess of five hundred million dollars

CITY OF ATWATER  
STATEMENT OF INVESTMENT POLICY  
Fiscal Year 2025-2026

ALLOWABLE INVESTMENTS AND ADDITIONAL INVESTMENT GUIDELINES

(\$500,000,000).

- 4) Issuing corporation must have an "A" or higher rating by a nationally recognized statistical-rating organization for the issuer's debt, other than commercial paper.
- 5) Purchases may not exceed 270 days maturity.
- 6) Purchases may not represent more than 10% of the outstanding paper of an issuing corporation.
- 7) Purchases may not exceed 25% of the agency's surplus money.

City of Atwater Limitation:

- 1) Maximum maturity- 270 days
- 2) Maximum par value size 25% of portfolio
- 3) Maximum par value per name- 10% of outstanding commercial paper of any single issuer, and no more than 5% of total portfolio may be invested in any single issuer.
- 4) Credit- CA Government Code Section 53601 requirements including commercial paper rated "A-1" or higher, or the equivalent, by a nationally recognized statistical ratings organization.

**8. Medium Term Notes:** The issuer is a corporation organized and operating within the United States or by depository institutions licensed by the United States or any state and operating within the United States.

California Government Code Section 53601 Requirement:

- 1) Maximum of five years maturity
- 2) Shall be rating category of 'A' or better by a nationally recognized statistical ratings organization.
- 3) May not exceed 30% of surplus money

City of Atwater Limitation:

- 1) Maximum of five years maturity
- 2) Shall be rating category of 'A' or better by a nationally recognized statistical ratings organization
- 3) Maximum par value per issuer- 5%
- 4) Credit – from City authorized institutions that shall only include institutions rated in a rating category of 'A' or higher by a nationally recognized statistical-rating organization. Any downgrading of these issues after purchase shall be reported to the Council.

**9. Local Agency Investment Fund (LAIF)** was established by the State to enable treasurers to place funds in a pool for investments.

LAIF Limitations:

Maximum per California Government Code

City of Atwater Limitation:

1. LAIF limitation

**10. Repurchase Agreements** are not a security but a contractual agreement and consist of two simultaneous transactions: 1) First, an investor purchases securities (collateral) from a bank or dealer; 2) At the same time, the selling bank or dealer contractually agrees to repurchase the

CITY OF ATWATER  
STATEMENT OF INVESTMENT POLICY  
Fiscal Year 2025-2026

ALLOWABLE INVESTMENTS AND ADDITIONAL INVESTMENT GUIDELINES

collateral security at the same price (plus interest) at some mutually agreed future date.

California Government Code Section 53601 Requirement:

- 1) Term of repurchase agreements shall be for one year or less.
- 2) All securities under a repurchase agreement shall be held by the agency's safekeeping agent.
- 3) The seller of repurchase securities shall not be entitled to substitute securities, except as authorized by the City. New or substitute securities should be reasonably identical to the original securities in terms of maturity, yield, quality and liquidity.

City of Atwater Limitation:

- 1) Maximum maturity – one year
- 2) Maximum par value total size - 10%
- 3) Maximum par value per institution - 10%
- 4) Credit-
  - a) Securities shall be marked to market daily and shall be maintained at a value no lower than \$102.
  - b) Securities acceptable as collateral shall be U.S. Treasury obligations only.
  - c) It should be covered by a master repurchase agreement.
- 5) Repurchase agreements shall only be made with primary dealers of the Federal Reserve Bank of New York.

11. **Asset Backed Securities (ABS)/ Mortgage Back Securities (MBS)** are securities whose value is derived from the collateral of a specified pool of underlying assets. The pools of underlying assets can include common payments from the loans and leases of credit cards, autos, equipment and mortgages.

California Government Code Section 53601 (o) Requirement:

- 1) Maximum Maturity 5 years or less.
- 2) Shall be rated in a rating category of 'AA' or better by a nationally recognized statistical ratings organization.
- 3) Maximum par value total size- 20% of portfolio

City of Atwater Limitation:

- 1) Maximum maturity – 5 years or less
- 2) Maximum par value total size - 20%
- 3) Maximum par value per institution – 5%
- 4) Credit: In a rating category of 'AA' or better by a nationally recognized statistical ratings organization.
- 5) This section does not apply for issuers in section 2 (US agency and Government Securities).

12. **Supranationals Obligations:** Supranationals are international institutions that provide development financing, advisory services and/or other financial services to their member countries.

CITY OF ATWATER  
STATEMENT OF INVESTMENT POLICY  
Fiscal Year 2025-2026

ALLOWABLE INVESTMENTS AND ADDITIONAL INVESTMENT GUIDELINES

California Government Code Section 53601(q) Requirement:

- 1) Maximum of five years maturity or less
- 2) Shall be rated in a rating category of 'AA' or better by a nationally recognized statistical ratings organization.
- 3) May not exceed 30% of surplus money

City of Atwater Limitation:

- 1) Maximum of five years maturity or less
- 2) Shall be rated in a rating category of 'AA' or better by a nationally recognized statistical ratings organization
- 3) Maximum value not to exceed 30% of portfolio value
- 4) No more than 10% of the portfolio may be invested in any single issuer.
- 5) Credit –Any downgrading of these issues after purchase shall be reported to the Council.

13. **Mutual Funds and Money Market Mutual Funds** that are registered with the Securities and Exchange Commission under the Investment Company Act of 1940, provided that:

1. MUTUAL FUNDS that invest in the securities and obligations as authorized under California Government Code, Section 53601 (a) to (k) and (m) to (q) inclusive and that meet either of the following criteria:
  - (i) Attained the highest ranking or the highest letter and numerical rating provided by not less than two (2) NRSROs; or
  - (ii) Have retained an investment adviser registered or exempt from registration with the Securities and Exchange Commission with not less than five years' experience investing in the securities and obligations authorized by California Government Code, Section 53601 and with assets under management in excess of \$500 million.
  - No more than 10% of the total portfolio may be invested in shares of any one mutual fund.
2. MONEY MARKET MUTUAL FUNDS registered with the Securities and Exchange Commission under the Investment Company Act of 1940 and issued by diversified management companies and meet either of the following criteria:
  - (i) Have attained the highest ranking or the highest letter and numerical rating provided by not less than two (2) NRSROs; or
  - (ii) Have retained an investment adviser registered or exempt from registration with the Securities and Exchange Commission with not less than five years' experience managing money market mutual funds with assets under management in excess of \$500 million.

California Government Code Section 53601(q) Requirement:

- 1) Maximum maturity: no limit specified
2. a) Attained the highest ranking or the highest letter and numerical rating provided by not less than two (2) NRSROs; or b) Have retained an investment adviser registered

CITY OF ATWATER  
STATEMENT OF INVESTMENT POLICY  
Fiscal Year 2025-2026

ALLOWABLE INVESTMENTS AND ADDITIONAL INVESTMENT GUIDELINES

or exempt from registration with the Securities and Exchange Commission with not less than five years' experience investing in the securities and obligations authorized by California Government Code, Section 53601 and with assets under management in excess of \$500 million.

- 3) May not exceed 20% of portfolio

City of Atwater Limitation:

- 1) Maximum maturity not specified
- 2 a) Attained the highest ranking or the highest letter and numerical rating provided by not less than two (2) NRSROs; or b) Have retained an investment adviser registered or exempt from registration with the Securities and Exchange Commission with not less than five years' experience investing in the securities and obligations authorized by California Government Code, Section 53601 and with assets under management in excess of \$500 million.
- 3) No more than 20% of the total portfolio may be invested in these securities
- 4) Investment Limitations:
  - Mutual Funds: No more than 10% of the total portfolio may be invested in shares of any one mutual fund
  - Money Market Funds: No more than 20% of the total portfolio may be invested in shares of any one money market fund

CITY OF ATWATER  
STATEMENT OF INVESTMENT POLICY  
Fiscal Year 2025-2026

ALLOWABLE INVESTMENTS AND ADDITIONAL INVESTMENT GUIDELINES

---

**GLOSSARY OF INVESTMENT TERMS**

**AGENCIES.** Shorthand market terminology for any obligation issued by a *government-sponsored entity (GSE)*, or a *federally related institution*. Most obligations of GSEs are not guaranteed by the full faith and credit of the US government. Examples are:

**FFCB.** The Federal Farm Credit Bank System provides credit and liquidity in the agricultural industry. FFCB issues discount notes and bonds.

**FHLB.** The Federal Home Loan Bank provides credit and liquidity in the housing market. FHLB issues discount notes and bonds.

**FHLMC.** Like FHLB, the Federal Home Loan Mortgage Corporation provides credit and liquidity in the housing market. FHLMC, also called “FreddieMac” issues discount notes, bonds and mortgage pass-through securities.

**FNMA.** Like FHLB and FreddieMac, the Federal National Mortgage Association was established to provide credit and liquidity in the housing market. FNMA, also known as “FannieMae,” issues discount notes, bonds and mortgage pass-through securities.

**GNMA.** The Government National Mortgage Association, known as “GinnieMae,” issues mortgage pass-through securities, which are guaranteed by the full faith and credit of the US Government.

**PEFCO.** The Private Export Funding Corporation assists exporters. Obligations of PEFCO are not guaranteed by the full faith and credit of the US government.

**TVA.** The Tennessee Valley Authority provides flood control and power and promotes development in portions of the Tennessee, Ohio, and Mississippi River valleys. TVA currently issues discount notes and bonds.

**ASSET BACKED SECURITIES.** Securities supported by pools of installment loans or leases or by pools of revolving lines of credit.

**AVERAGE LIFE.** In mortgage-related investments, including CMOs, the average time to expected receipt of principal payments, weighted by the amount of principal expected.

**BANKER’S ACCEPTANCE.** A money market instrument created to facilitate international trade transactions. It is highly liquid and safe because the risk of the trade transaction is transferred to the bank which “accepts” the obligation to pay the investor.

**BENCHMARK.** A comparison security or portfolio. A performance benchmark is a partial market index, which reflects the mix of securities allowed under a specific investment policy.

**BROKER.** A broker brings buyers and sellers together for a transaction for which the broker

CITY OF ATWATER  
STATEMENT OF INVESTMENT POLICY  
Fiscal Year 2025-2026

ALLOWABLE INVESTMENTS AND ADDITIONAL INVESTMENT GUIDELINES

receives a commission. A broker does not sell securities from his own position.

**CALLABLE.** A callable security gives the issuer the option to call it from the investor prior to its maturity. The main cause of a call is a decline in interest rates. If interest rates decline, the issuer will likely call its current securities and reissue them at a lower rate of interest.

**CERTIFICATE OF DEPOSIT (CD).** A time deposit with a specific maturity evidenced by a certificate.

**CERTIFICATE OF DEPOSIT ACCOUNT REGISTRY SYSTEM (CDARS).** A private placement service that allows local agencies to purchase more than \$250,000 in CDs from a single financial institution (must be a participating institution of CDARS) while still maintaining FDIC insurance coverage. CDARS is currently the only entity providing this service. CDARS facilitates the trading of deposits between the California institution and other participating institutions in amounts that are less than \$250,000 each, so that FDIC coverage is maintained.

**COLLATERAL.** Securities or cash pledged by a borrower to secure repayment of a loan or repurchase agreement. Also, securities pledged by a financial institution to secure deposits of public monies.

**COLLATERALIZED BANK DEPOSIT.** A bank deposit that is collateralized at least 100% (principal plus interest to maturity). The deposit is collateralized using assets set aside by the issuer such as Treasury securities or other qualified collateral to secure the deposit in excess of the limit covered by the Federal Deposit Insurance Corporation.

**COLLATERALIZED MORTGAGE OBLIGATIONS (CMO).** Classes of bonds that redistribute the cash flows of mortgage securities (and whole loans) to create securities that have different levels of prepayment risk, as compared to the underlying mortgage securities.

**COLLATERALIZED TIME DEPOSIT.** Time deposits that are collateralized at least 100% (principal plus interest to maturity). These instruments are collateralized using assets set aside by the issuer such as Treasury securities or other qualified collateral to secure the deposit in excess of the limit covered by the Federal Deposit Insurance Corporation.

**COMMERCIAL PAPER.** The short-term unsecured debt of corporations.

**COUPON.** The rate of return at which interest is paid on a bond.

**CREDIT RISK.** The risk that principal and/or interest on an investment will not be paid in a timely manner due to changes in the condition of the issuer.

**DEALER.** A dealer acts as a principal in security transactions, selling securities from and buying securities for his own position.

**DEBENTURE.** A bond secured only by the general credit of the issuer.

**DELIVERY VS. PAYMENT (DVP).** A securities industry procedure whereby payment for a security

CITY OF ATWATER  
STATEMENT OF INVESTMENT POLICY  
Fiscal Year 2025-2026

ALLOWABLE INVESTMENTS AND ADDITIONAL INVESTMENT GUIDELINES

must be made at the time the security is delivered to the purchaser's agent.

**DERIVATIVE.** Any security that has principal and/or interest payments which are subject to uncertainty (but not for reasons of default or credit risk) as to timing and/or amount, or any security which represents a component of another security which has been separated from other components ("Stripped" coupons and principal). A derivative is also defined as a financial instrument the value of which is totally or partially derived from the value of another instrument, interest rate, or index.

**DISCOUNT.** The difference between the par value of a bond and the cost of the bond, when the cost is below par. Some short-term securities, such as T-bills and banker's acceptances, are known as discount securities. They sell at a discount from par and return the par value to the investor at maturity without additional interest. Other securities, which have fixed coupons, trade at a discount when the coupon rate is lower than the current market rate for securities of that maturity and/or quality.

**DIVERSIFICATION.** Dividing investment funds among a variety of investments to avoid excessive exposure to any one source of risk.

**DURATION.** The weighted average time to maturity of a bond where the weights are the present values of the future cash flows. Duration measures the price sensitivity of a security to changes interest rates.

**FEDERAL DEPOSIT INSURANCE CORPORATION (FDIC).** The Federal Deposit Insurance Corporation (FDIC) is an independent federal agency insuring deposits in U.S. banks and thrifts in the event of bank failures. The FDIC was created in 1933 to maintain public confidence and encourage stability in the financial system through the promotion of sound banking practices.

**FEDERALLY INSURED TIME DEPOSIT.** A time deposit is an interest-bearing bank deposit account that has a specified date of maturity, such as a certificate of deposit (CD). These deposits are limited to funds insured in accordance with FDIC insurance deposit limits.

**FIDUCIARY.** A person or organization that acts on behalf of another person(s) or organization that puts their clients' interest ahead of their own as they are bound both legally and ethically to act in the other's best interests.

**LEVERAGE.** Borrowing funds in order to invest in securities that have the potential to pay earnings at a rate higher than the cost of borrowing.

**LIQUIDITY.** The speed and ease with which an asset can be converted to cash.

**LOCAL AGENCY INVESTMENT FUND (LAIF).** A voluntary investment fund open to government entities and certain non-profit organizations in California that is managed by the State Treasurer's Office.

**LOCAL GOVERNMENT INVESTMENT POOL.** Investment pools that range from the State Treasurer's

CITY OF ATWATER  
STATEMENT OF INVESTMENT POLICY  
Fiscal Year 2025-2026

**ALLOWABLE INVESTMENTS AND ADDITIONAL INVESTMENT GUIDELINES**

Office Local Agency Investment Fund (LAIF) to county pools, to Joint Powers Authorities (JPAs). These funds are not subject to the same SEC rules applicable to money market mutual funds.

**MAKE WHOLE CALL.** A type of call provision on a bond that allows the issuer to pay off the remaining debt early. Unlike a call option, with a make whole call provision, the issuer makes a lump sum payment that equals the net present value (NPV) of future coupon payments that will not be paid because of the call. With this type of call, an investor is compensated, or "made whole."

**MARGIN.** The difference between the market value of a security and the loan a broker makes using that security as collateral.

**MARKET RISK.** The risk that the value of securities will fluctuate with changes in overall market conditions or interest rates.

**MARKET VALUE.** The price at which a security can be traded.

**MATURITY.** The final date upon which the principal of a security becomes due and payable. The investment's term or remaining maturity is measured from the settlement date to final maturity.

**MEDIUM TERM NOTES.** Unsecured, investment-grade senior debt securities of major corporations which are sold in relatively small amounts on either a continuous or an intermittent basis. MTNs are highly flexible debt instruments that can be structured to respond to market opportunities or to investor preferences.

**MODIFIED DURATION.** The percent change in price for a 100-basis point change in yields. Modified duration is the best single measure of a portfolio's or security's exposure to market risk.

**MONEY MARKET.** The market in which short-term debt instruments (T-bills, discount notes, commercial paper, and banker's acceptances) are issued and traded.

**MONEY MARKET MUTUAL FUND.** A mutual fund that invests exclusively in short-term securities. Examples of investments in money market funds are certificates of deposit and U.S. Treasury securities. Money market funds attempt to keep their net asset values at \$1 per share.

**MORTGAGE PASS-THROUGH SECURITIES.** A securitized participation in the interest and principal cash flows from a specified pool of mortgages. Principal and interest payments made on the mortgages are passed through to the holder of the security.

**MUNICIPAL SECURITIES.** Securities issued by state and local agencies to finance capital and operating expenses.

**MUTUAL FUND.** An entity which pools the funds of investors and invests those funds in a set of securities which is specifically defined in the fund's prospectus. Mutual funds can be

CITY OF ATWATER  
STATEMENT OF INVESTMENT POLICY  
Fiscal Year 2025-2026

**ALLOWABLE INVESTMENTS AND ADDITIONAL INVESTMENT GUIDELINES**

invested in various types of domestic and/or international stocks, bonds, and money market instruments, as set forth in the individual fund's prospectus. For most large, institutional investors, the costs associated with investing in mutual funds are higher than the investor can obtain through an individually managed portfolio.

**NATIONALLY RECOGNIZED STATISTICAL RATING ORGANIZATION (NRSRO).**

A credit rating agency that the Securities and Exchange Commission in the United States uses for regulatory purposes. Credit rating agencies provide assessments of an investment's risk. The issuers of investments, especially debt securities, pay credit rating agencies to provide them with ratings. The three most prominent NRSROs are Fitch, S&P, and Moody's.

**NEGOTIABLE CERTIFICATE OF DEPOSIT (CD).** A short-term debt instrument that pays interest and is issued by a bank, savings or federal association, state or federal credit union, or state-licensed branch of a foreign bank. Negotiable CDs are traded in a secondary market and are payable upon order to the bearer or initial depositor (investor).

**PAYDOWN.** A reduction in the principal amount owed on a bond, loan, or other debt.

**PRIMARY DEALER.** A financial institution (1) that is a trading counterparty with the Federal Reserve in its execution of market operations to carry out U.S. monetary policy, and (2) that participates for statistical reporting purposes in compiling data on activity in the U.S. Government securities market.

**PRUDENT PERSON (PRUDENT INVESTOR) RULE.** A standard of responsibility which applies to fiduciaries. In California, the rule is stated as "Investments shall be managed with the care, skill, prudence and diligence, under the circumstances then prevailing, that a prudent person, acting in a like capacity and familiar with such matters, would use in the conduct of an enterprise of like character and with like aims to accomplish similar purposes."

**REPURCHASE AGREEMENT.** Short-term purchases of securities with a simultaneous agreement to sell the securities back at a higher price. From the seller's point of view, the same transaction is a reverse repurchase agreement.

**SAFEKEEPING.** A service to bank customers whereby securities are held by the bank in the customer's name.

**SECURITIES AND EXCHANGE COMMISSION (SEC).** The U.S. Securities and Exchange Commission (SEC) is an independent federal government agency responsible for protecting investors, maintaining fair and orderly functioning of securities markets and facilitating capital formation. It was created by Congress in 1934 as the first federal regulator of securities markets. The SEC promotes full public disclosure, protects investors against fraudulent and manipulative practices in the market, and monitors corporate takeover actions in the United States.

CITY OF ATWATER  
STATEMENT OF INVESTMENT POLICY  
Fiscal Year 2025-2026

ALLOWABLE INVESTMENTS AND ADDITIONAL INVESTMENT GUIDELINES

**SECURITIES AND EXCHANGE COMMISSION SEC) RULE 15c3-1.** An SEC rule setting capital requirements for brokers and dealers. Under Rule 15c3-1, a broker or dealer must have sufficient liquidity in order to cover the most pressing obligations. This is defined as having a certain amount of liquidity as a percentage of the broker/dealer's total obligations. If the percentage falls below a certain point, the broker or dealer may not be allowed to take on new clients and may have restrictions placed on dealings with current client.

**STRUCTURED NOTE.** A complex, fixed income instrument, which pays interest, based on a formula tied to other interest rates, commodities or indices. Examples include inverse floating rate notes which have coupons that increase when other interest rates are falling, and which fall when other interest rates are rising, and "dual index floaters," which pay interest based on the relationship between two other interest rates - for example, the yield on the ten-year Treasury note minus the Libor rate. Issuers of such notes lock in a reduced cost of borrowing by purchasing interest rate swap agreements.

**SUPRANATIONAL.** A Supranational is a multi-national organization whereby member states transcend national boundaries or interests to share in the decision making to promote economic development in the member countries.

**TOTAL RATE OF RETURN.** A measure of a portfolio's performance over time. It is the internal rate of return, which equates the beginning value of the portfolio with the ending value; it includes interest earnings, realized and unrealized gains, and losses in the portfolio.

**U.S. TREASURY OBLIGATIONS.** Securities issued by the U.S. Treasury and backed by the full faith and credit of the United States. Treasuries are considered to have no credit risk and are the benchmark for interest rates on all other securities in the US and overseas. The Treasury issues both discounted securities and fixed coupon notes and bonds.

**TREASURY BILLS ("T-BILL").** All securities issued with initial maturities of one year or less are issued as discounted instruments and are called Treasury bills. The Treasury currently issues three- and six-month T-bills at regular weekly auctions. It also issues "cash management" bills as needed to smooth out cash flows.

**TREASURY NOTES.** All securities issued with initial maturities of two to ten years are called Treasury notes and pay interest semi-annually.

**TREASURY BONDS.** All securities issued with initial maturities greater than ten years are called Treasury bonds. Like Treasury notes, they pay interest semi-annually.

**YIELD TO MATURITY.** The annualized internal rate of return on an investment which equates the expected cash flows from the investment to its cost.



## CITY COUNCIL AGENDA REPORT

### CITY COUNCIL

Mike Nelson, Mayor  
Danny Ambriz      Brian Raymond  
John Cale          Kalisa Rochester

**MEETING DATE:** June 9, 2025  
**TO:** Mayor and City Council  
**FROM:** Anna Nicholas, Finance Director  
**PREPARED BY:** Anna Nicholas, Finance Director  
**SUBJECT:** **Adopting a Resolution Setting the Fiscal Year 2025-26 Miscellaneous Fee Schedule** (Finance Director Nicholas)

---

### **RECOMMENDED COUNCIL ACTION**

Open the Public Hearing and receive any testimony given regarding the proposed 2025-26 Miscellaneous Fee Schedule;

Close the Public Hearing;

Motion to adopt Resolution No. 3537-25 setting the City of Atwater's Miscellaneous Fee Schedule for Fiscal Year 2025-26; or

Motion to approve staff's recommendation as presented.

### **I. BACKGROUND/ANALYSIS:**

Each fiscal year, the City of Atwater sets the Citywide Miscellaneous Fee Schedule to assist with cost recovery for providing services. The proposed Miscellaneous Fee Schedule provides a legally defensible cost-recovery program to ensure that the City receives appropriate fees for services provided and supports the City Council's goal of following sound financial practices.

The Miscellaneous Fee Schedule is adjusted annually every July 1st after City Council approval. After reviewing the existing fees, if necessary, adjustments are made using the U.S. Bureau of Labor Statistics, Consumer Price Index, All Urban Consumers (Not Seasonally Adjusted) -West Region, by the percentage of change in the index from the month of April of the same year. All amounts are rounded to the nearest whole dollar.

The percentage of increase in the index over the past year was 2.128%, this is by comparison of 3.682% which was applied for Fiscal Year 2024-25. The proposed Miscellaneous Fee Schedule reflects this percentage increase in each fee, where applicable.

Of note, the City is currently under study with a consultant to produce a new Master Fee Schedule and will be brought forward to City Council in the future for review, consideration and approval.

**II. FISCAL IMPACTS:**

This item has been reviewed by the Finance Department.

**III. LEGAL REVIEW:**

This item has been reviewed by the City Attorney's Office.

**IV. EXISTING POLICY:**

This item is consistent with goal number one (1) of the City of Atwater 2020-2025 Strategic Plan: to ensure the city's continued financial stability.

**V. ALTERNATIVES:**

The City Council could choose not to adopt the Fiscal Year 2025-26 Miscellaneous Fee Schedule as presented.

**VI. INTERDEPARTMENTAL COORDINATION:**

The annual review and update of the Fiscal Year 2025-26 Miscellaneous Fee Schedule is a coordinated effort among all the departments in the City.

**VII. PUBLIC PARTICIPATION:**

The public will have an opportunity to provide comments on this item prior to City Council action.

**VIII. ENVIRONMENTAL REVIEW:**

This item is not a "project" under the California Environmental Quality Act (CEQA) as this activity does not cause either a direct physical change in the environment, or a reasonably foreseeable indirect physical change in the environment, pursuant to Public Resources Code Section 21065.

**IX. STEPS FOLLOWING APPROVAL:**

Upon adoption of Resolution No. 3537-25, setting the Miscellaneous Fee Schedule, the City Clerk will circulate the FY 2025-26 to all departments to begin charging the revised fees upon the effective date. In addition, the FY 2025-26 Miscellaneous Fee Schedule will be available on the City's website.

Submitted by:



---

Anna Nicholas, Finance Director

Approved by:



---

Chris Hoem, City Manager

Attachments:

1. Resolution Miscellaneous Fee Schedule FY 2025-26
2. FY 2025-26-MASTER MISC FEE SCHEDULE-FINAL to Council 06092025



**CITY COUNCIL  
OF THE  
CITY OF ATWATER**

**RESOLUTION NO. 3537-25**

**RESOLUTION OF THE CITY COUNCIL OF THE  
CITY OF ATWATER SETTING THE FISCAL YEAR  
2025-26 MISCELLANEOUS FEE SCHEDULE**

**WHEREAS**, the City of Atwater has established a Citywide fee structure “Miscellaneous Fee Schedule” to offset the costs of services; and

**WHEREAS**, the City of Atwater’s Miscellaneous Fee Schedule is adopted by resolution; and

**WHEREAS**, the City Council adopted Resolution No. 3502-24 setting the most recent Miscellaneous Fee Schedule on October 28, 2024; and

**WHEREAS**, the Miscellaneous Fee Schedule has been amended from time to time by resolution to amend said fees and changes for described services.

**NOW, THEREFORE, BE IT RESOLVED** by the City Council of the City of Atwater as follows:

- A. All previous resolutions that set and/or amended the Miscellaneous Fee Schedule are hereby repealed and superseded by Resolution No. 3537-25.
- B. The Miscellaneous Fee Schedule, attached hereto as **EXHIBIT “A”** and made a part of herein, is hereby approved.
- C. The purpose of the fees set forth in the City’s Miscellaneous Fee Schedule **EXHIBIT “A”** of this resolution is to recover up to the full, lawfully recoverable costs incurred by the City.
- D. **Effective Date.** All new and/or increased fees shall be effective upon adoption of this resolution with the exception of fees established in accordance with Government Code Section 66017. Development related new and/or increased fees shall be effective sixty (60) days following the effective date of this resolution.
- E. **Annual Adjustment.** Said miscellaneous fees shall be adjusted annually every July 1<sup>st</sup> according to the U.S. Bureau of Labor Statistics, Consumer Price Index, All Urban Consumers (Not Seasonally Adjusted). West Region, by the percentage

of change in the index from the month of April of the same year. Rounding shall be as follows: .01 to .49 shall be rounded down to the nearest whole dollar; .50 to .99 shall be rounded up to the nearest whole dollar.

- F. **Repealer.** These fees shall supersede the corresponding fees previously established by the City. All previously adopted and conflicting fees, and all resolutions and other actions of the City Council are hereby repealed to the extent they conflict with the contents of this resolution.
  
- G. **Severability.** The individual fees and charges set forth in **EXHIBIT “A”** of this resolution and portions of this resolution are severable. Should any of the fees or charges or any portion of this resolution be adjudged to be invalid and unenforceable by a body of competent jurisdiction, then the remaining fees, charges and/or resolution portions shall be and continue in full force and effect, except as to those fee, charges, and/or resolution portions that have been adjudged invalid. The City Council of the City of Atwater hereby declared that is would have adopted each of the fee and charges set forth in **EXHIBIT “A”** of this resolution, and this resolution and each section, subsection, clause, sentence, phrase and other portion thereof, irrespective of the fact that one or more of the fees, charges, or sections, subsections, clauses, sentences, phrases or other portions of this resolution may be held invalid or unconstitutional.

The foregoing resolution is hereby adopted this 9<sup>th</sup> day of June 2025.

**AYES:**  
**NOES:**  
**ABSENT:**

**APPROVED:**

\_\_\_\_\_  
**MIKE NELSON, MAYOR**

**ATTEST:**

\_\_\_\_\_  
**KORY J. BILLINGS, CITY CLERK**

**Miscellaneous Fee Schedule**  
**Fiscal Year 2025-26**

CPI% increase for FY 25/26

**2.128%**

**MISCELLANEOUS FEES:**

**2025-26**

Cost Recovery, Legal Services				Actual Cost
Cost Recovery, Liability Claim Processing				Actual Cost
Notary Services (as set by GC 8211) <b>No COLA associated</b>				\$15 per signature
Mailed Copies of City Council Agenda (per fiscal year)				\$45
Mailed Copies of City Council Minutes (per fiscal year)				\$42
Mailed Copies of City Council and Planning Agendas and Minutes (per fiscal year)				\$151
Copy of City Council Video DVD				\$13
Final Budget (summary)				\$14
Final Budget				\$55
Copy of Municipal Code to CD				\$13
Preliminary Budget				\$38
Annual Financial Statement				\$34
Five Year Capital Improvement Budget				\$22
Voucher				\$39
Business License Listing				\$29
Mailing Labels for Business License				\$39
Abatement Lien				\$50
Photocopies (first page)				\$4
Photocopies (per copy of B/W)				\$0.13
Photocopies (per copy of color)				\$0.22
Public Hearing Processing Fee				Actual Cost
Returned Items				\$48
Electronic Payment Processing Fees				Up to 5% of the total amount
Donation Bin Permit/Renewal Processing Fee				\$50 annually
Donation Bin Permit Sticker (replacement)				\$14
Research				Actual Cost
<b>COMMUNITY DEVELOPMENT:</b>				
<b>BUILDING DIVISION:</b>				
Building Inspection Fee (minimum 1 hour)				\$130 per hour
Monthly Building Activity Reports (per fiscal year)				\$35
Building Permit Plan Reproduction (smaller than 11x17)				\$90
Building Permit Plan Reproduction (larger than 11x17)				\$178
<b>PLANNING DIVISION:</b>				
Building Permit Application Plan Review (15 mins.)				\$57
Building Permit Application Plan Review (16 to 30 mins.)				\$114
Building Permit Application Plan Review (over 30 mins.)				\$228
General Plan (Copy or Disk)				\$69
General Plan EIR (Copy or Disk)				\$74
Specific Plan Application				Deposit \$10,373, Actual Cost + 20%
Specific Plan Preparation				Actual cost + 20%
Housing Element (Copy or Disk)				\$46
General Plan or Zoning Map Reproduction				\$17
Street Tree Master Plan				\$38
Annexation Application				\$3,128 plus \$115 per acre
Appeal of Staff Decision to Planning Commission				\$248

**Miscellaneous Fee Schedule**  
**Fiscal Year 2025-26**

CPI% increase for FY 25/26

**2.128%**

**MISCELLANEOUS FEES:**

**2025-26**

Appeal of Planning Commission Decision to City Council				\$248
Environmental Assessment (Review of private prepared document)				Actual Cost + 20%
Environmental Assessment Preparation for Private Development Project				Actual Cost + 20%
Environmental Impact Report Preparation				Actual Cost + 20%
General Plan Amendment Preparation				Deposit \$2,074, Actual cost + 20%
Home Occupation Permit				\$229
Lot Line Adjustment				Deposit \$690 + actual cost
Lot Merger				Deposit \$690 + actual cost
Monthly Building Activity Reports (per fiscal year)				\$35
Pre-zoning				Deposit \$2,084 + actual cost
Reversion to Acreage				Deposit \$690 + actual cost
Sign Review				\$194
Site & Architectural Plan Review				Deposit \$1,050 + actual cost
Tentative Subdivision Map				Deposit \$3,110 + \$62 per lot, Actual Cost + 20%
Tentative Parcel Map				Deposit \$1,915 + \$62 per lot, Actual Cost + 20%
Condominium Conversion				Actual Cost + 20%
Regular Conditional Use Permit				Actual Cost. \$2,000 Minimum Deposit
Conditional Use Permit Amendment				\$369
Conditional Use Permit Monitoring				\$150 Annually
Commercial Conditional Use Permit General Plan Update Fee				\$253
Variance				Deposit \$1,014, Actual Cost + 20%
Zone Change				Deposit \$1,886, Actual Cost + 20%
Zoning Ordinance Text Amendment				Deposit \$1,886, Actual Cost + 20%
Time Extension Request Application				Original Application Fee
Planned Development Zone:				
Master Plan Application				Deposit \$2,290, Actual Cost + 20%
Final Development Plan Application				Deposit \$2,290, Actual Cost + 20%
Planned Development Amendment:				Deposit \$1,154, Actual Cost + 20%
Development Agreement Preparation				Actual Cost + 20%
<b>BUSINESS LICENSE:</b>				
Nonrefundable License Application Fee				\$41
Appeal Fee				Actual Cost
Amendment to Business License Fee				\$31
Duplicate License Fee				\$5
<b>CANNABIS REGULATORY PERMIT:</b>				
Cannabis Application Fee				Actual Cost. \$1,500 Minimum Deposit
Cannabis Application Renewal Fee				\$352
Appeal Fee				Actual Cost
Cannabis Regulatory Permit, Annual				\$15,000
Cannabis Regulatory Permit Amendment				\$400
<b>ENGINEERING DIVISION:</b>				

**Miscellaneous Fee Schedule**  
**Fiscal Year 2025-26**

CPI% increase for FY 25/26

**2.128%**

**MISCELLANEOUS FEES:**

**2025-26**

Cost Recovery, Legal Services				Actual Cost + 20%
Improvement Standards and Specifications Book				\$39
Map or Document Research (minimum 1 hour)				Actual Cost + 20%
Improvement Plans Review, City Staff				3% of value
Improvement Plans Review, Consultant				Deposit 3% of value, Actual Cost + 20%
Traffic Plan Check Review				Actual Cost
Storm Water Quality Control Plan Review				\$820
Swimming Pool Permit				\$39
Encroachment Permit				3% of value ( \$264 minimum)
Encroachment Permit for Public Utilities (AT&T, PG&E, MID, Comcast, etc.)				\$318
Inspections for Public Utilities Company Permits, City Staff				\$137 per hour
Inspections for Public Utilities Company Permits, Consultant				Actual Cost + 20%
Well Construction (except drinking water)				\$318
Well Abandonment				\$318
Encroachment Permit for Driveway Approach Replacement				\$318
Encroachment Permit for Sidewalk Replacement				\$318
Encroachment Permit for Utilities Installation (Street Cuts)				\$428
*Trench Deposit, Single Utility (held for 12 months)				Deposit \$2,538 + Actual Cost
*Trench Deposit, Multi Utilities (12 months from excavation of last trench)				Deposit \$6,679 + Actual Cost
*Trench deposits are not required for projects covered under a warranty bond				
On-Site Inspections				3% of value
Off-Site Inspections				3% of value
False Alarms (within a 12 month period at a single site) <b>False alarms are not subject to CPI Adjustment</b>				
<b>PUBLIC WORKS:</b>				
Administrative Fee				20% for all billable charges
Street Sweeper and Clean-Up Fee (minimum 2 hours)				Actual Cost
Barricade Rental				\$6 each-first day, \$1 each-each day after
Emergency Labor, Equipment and Materials				Actual Cost
Hydrant Use or Construction Water (meter cost plus actual cost)				Deposit \$559 plus installation \$47 plus \$5 per thousand gallons of usage
Delinquent Backflow Testing				\$150 plus actual cost for repair parts if needed
Water Problem (call out) Evaluation (minimum 2 hours)				Actual Cost
After Hour Reconnection Fee (SB 998)				\$159
Red Tags (second and subsequent notices)				Actual Cost
Commercial Recycling				Actual Cost plus 11%
<b>POLICE:</b>				
Background Check Fee				\$139
Copies				.10 cents (per page)
Photos				\$15 per CD; \$1 per page if printed
Unconsensual Franchise Tow Fee (Per Vehicle)				\$63
Second Hand Dealer/Pawn Broker License (initial)				
False Alarms (first and second incident)				\$0
False Alarms (third thru fifth**)				\$69

**Miscellaneous Fee Schedule**  
**Fiscal Year 2025-26**

CPI% increase for FY 25/26

**2.128%**

**MISCELLANEOUS FEES:**

**2025-26**

False Alarms (sixth and subsequent**)					\$138
False Alarms (maximum fee per day)					\$345
<b>**If both Police and Fire respond to false alarm, only one charge shall be assessed per incident</b>					
Domestic Fowl/Animal Permit					\$31
Cats/Dogs Redeemed (first occurrence)					\$71
Cats/Dogs Redeemed (second occurrence)					\$143
Animals to Pound, Requested by Owner					\$127
Clearance Letter					\$32
Dance Permit					\$38
Fingerprint Card					\$63
Bicycle License					\$7
Amplified Sound Permit					\$51
Second Hand Dealer/Pawn Broker License (renewal)					\$38
Alcohol Consumption Permit (City property, per event)					\$51
Solicitor Permit (non-profit)					\$25
Solicitor Permit (profit)					\$50
Handgun Dealer Permit (initial)					\$50
Handgun Dealer Permit (renewal)					\$32
Neighborhood Watch Program					
Police Reports, Crime/Accident (first 4 pages)					\$25
Jail Booking					County Cost plus 20%
Citation Sign-Off (for non-Atwater resident)					\$19
Stored Vehicle Release					\$288
Repossession Filing Fee (mandated by State Gov. Code 41612)					\$20
Concealed Weapon Permit (initial)					\$225
Concealed Weapon Permit (renewal)					\$174
Emergency Response (Gov. Code 53150-53158)					Actual Cost plus 15%
1 - 5,000 sq. ft.					\$51
Taxi Cab Permit (initial)					\$51
Taxi Cab Permit (renewal)					\$32
Tow Cab Franchise Fee					\$63
Abandoned Cart Fee					\$50 per cart, per pick-up
Code Enforcement Reinspection Fee					\$56
<b>FIRE:</b>					
1,251 GPM (16 hour maximum) 1251-1500					\$96/hour
1,501 GPM (16 hour maximum) 1501-2000					\$98.50/hour
Pick-Up (16 hour maximum)					\$62/hour
Works Comp.					Actual Cost
Administration (OES)					Actual Cost
<b>Annual Inspections and New Business Inspections</b>					
Low Hazard Inspection (businesses, industries, merchandise) Per Hour: Occupancy types: A (<50 People), B, C, F-2, M, S-2, U					
1 - 5,000 sq. ft. (first inspection)					\$141
First Re-Inspection					\$157
Second Re-Inspection					\$173
5,001 - 10,000 sq. ft. (first inspection)					\$151

**Miscellaneous Fee Schedule**  
**Fiscal Year 2025-26**

CPI% increase for FY 25/26

**2.128%**

**MISCELLANEOUS FEES:**

**2025-26**

First Re-Inspection					\$167
Second Re-Inspection					\$183
10,001 - 20,000 sq. ft. (first inspection)					\$162
First Re-Inspection					\$178
Second Re-Inspection					\$194
20,001 - 40,000 sq. ft. (first inspection)					\$194
First Re-Inspection					\$210
Second Re-Inspection					\$226
40,001 - 80,000 sq. ft. (first inspection)					\$204
First Re-Inspection					\$220
Second Re-Inspection					\$236
80,001 - 120,000 sq. ft. (first inspection)					\$215
First Re-Inspection					\$231
Second Re-Inspection					\$247
120,001 - 150,000 sq. ft. (first inspection)					\$278
First Re-Inspection					\$294
Second Re-Inspection					\$310
150,001 - 200,000 sq. ft. (first inspection)					\$342
First Re-Inspection					\$358
Second Re-Inspection					\$374
200,001+ sq. ft. (first inspection)					\$406
First Re-Inspection					\$421
Second Re-Inspection					\$437
Moderate-High Hazard Inspection (50+ gather, education facility, high fire area, hospitals, residential, storage) Per Hour:					
Occupancy types: A (>50 People), E, F-1, H-1-5, I-1-3, I-4, L, R-1-4, S-1					
1 - 5,000 sq. ft. (first inspection)					\$141
First Re-Inspection					\$157
Second Re-Inspection					\$173
5,001 - 10,000 sq. ft. (first inspection)					\$151
First Re-Inspection					\$167
Second Re-Inspection					\$183
10,001 - 20,000 sq. ft. (first inspection)					\$162
First Re-Inspection					\$178
Second Re-Inspection					\$194
20,001 - 40,000 sq. ft. (first inspection)					\$215
First Re-Inspection					\$231
Second Re-Inspection					\$247
40,001 - 80,000 sq. ft. (first inspection)					\$226
First Re-Inspection					\$241
Second Re-Inspection					\$257
80,001 - 120,000 sq. ft. (first inspection)					\$236
First Re-Inspection					\$252
Second Re-Inspection					\$268
120,001 - 150,000 sq. ft. (first inspection)					\$321
First Re-Inspection					\$337
Second Re-Inspection					\$353

**Miscellaneous Fee Schedule**  
**Fiscal Year 2025-26**

CPI% increase for FY 25/26

**2.128%**

**MISCELLANEOUS FEES:**

**2025-26**

150,001 - 200,000 sq. ft. (first inspection)					\$406
First Re-Inspection					\$421
Second Re-Inspection					\$437
200,001+ sq. ft. (first inspection)					\$490
First Re-Inspection					\$506
Second Re-Inspection					\$522
Other Inspections/Rates:					
Inspections:					
Christmas Tree Lots or Sale Areas at Car Sales					\$67
Board and Care Facilities (full time patient care, State mandated inspection, 7 - 50 occupants)					\$142
Board and Care Facilities (full time patient care, State mandated inspection, over 50 occupants)					\$229
Daycare Facilities (more than 6 children, State mandated inspection)					\$142
Fire Safety Application Review					\$229
Fire Safety Plan Review					\$229
Aircraft Refueling Vehicle (initial)					\$333
Occupancy Permits					\$74
Penalty Charges (unauthorized occupancy)					\$155
Tents and Air-Supported Structures (per 200 sq. ft., except for camping)					\$126
Rates:					
Hydrant Flow Data-Per Hydrant					\$294
Weed Abatement					Contractors Cost plus 20%
Consultation					\$126
Fire Cause Investigation					\$126
Stand-by or Fire Watch					\$152
Operational Permits:					
Tanks: Hazardous Material Storage, Installation/Removal					\$152
Aerosol Products Permit (retail storage, under exempt amounts per sq. ft.)					\$137
Aerosol Products Permit (warehouse and storage)					\$274
Aircraft Repair Hanger					\$137
Commercial Rubbish Handling Operation (initial)					\$206
Aircraft Refueling Vehicle (renewal)					\$137
Asbestos Removal Permit					\$206
Automobile Wrecking Yard					\$206
Battery System					\$274
Bowling Pin or Alley Refinishing (initial)					\$274
Bowling Pin or Alley Refinishing (renewal)					\$217
Candles/Open Flame in Assembly Area (single use permit)					\$48
Candles/Open Flame in Assembly Area (on-going facility permit)					\$217
Carnivals and Fairs					\$154
Cellulose Nitrate Film					\$278
Cellulose Nitrate Storage					\$278
Combustible Fiber Storage					\$341
Combustible Material Storage					\$154
Compressed Gas, Store/Handle/Use (initial)					\$278
Compressed Gas, Store/Handle/Use (renewal)					\$154

**Miscellaneous Fee Schedule**  
**Fiscal Year 2025-26**

CPI% increase for FY 25/26

**2.128%**

**MISCELLANEOUS FEES:**

**2025-26**

Containers/Tanks (initial)					\$217
Commercial Rubbish Handling Operation (renewal)					\$154
Cryogen Use, Plan Check/Install/Inspection/Use (initial)					\$429
Cryogen Use, Plan Check/Install/Inspection/Use (renewal)					\$172
Dry Cleaning Plants (initial)					\$278
Dry Cleaning Plants (renewal)					\$217
Dust Producing Operation (initial)					\$278
Dust Producing Operation (renewal)					\$217
Explosive or Blasting Agent (permit and 2 blasts)					\$217
Explosive or Blasting Agent (more than 2 blasts)					\$67
Fireworks Ground Display					\$154
Fireworks, Pyrotechnic Special Effects (theatrical/movies)					\$154
Fireworks, Aerial Display (includes ground display)					\$341
Flammable or Combustible Liquids					\$341
Retail Storage (under exempt amount per control area)					\$67
Pipeline, Operations/Excavation					\$154
Liquid or Gas Fueled Vehicles or Equipment in Assembly					\$341
Containers/Tanks (renewal)					\$217
Underground Tanks					\$154
Tank Removal					\$217
Tank Vehicles (initial)					\$217
Tank Vehicles (renewal)					\$154
Fruit Ripening					\$154
Fumigation or Thermal Insecticides Fogging					\$154
Hazardous Materials, Retail Storage (under exempt amount per control area)					\$154
Hazardous Materials, Storage/Handle/Use (initial)					\$547
Hazardous Materials, Storage/Handle/Use (renewal)					\$217
Hazardous Production Materials					\$421
High Piled Combustible Stock (initial)					\$421
High Piled Combustible Stock (renewal)					\$278
LPG - Non Single Family Dwelling					\$278
LPG - Single Family Dwelling					\$154
Special Use/Event Permit					\$154
Lumber Yards					\$217
Magnesium Working					\$278
Mall Covered					\$278
Motor Vehicle Fuel Dispensing Station					\$278
Motor Vehicle Refueling Unit					\$278
Open Fires (includes bonfires & burn permits)					\$67
Organic Coating (initial)					\$543
Organic Coating (renewal)					\$417
Ovens, Industrial Baking or Drying (initial)					\$217
Ovens, Industrial Baking or Drying (renewal)					\$154
Radioactive Materials (initial)					\$278
Radioactive Materials (renewal)					\$154

**Miscellaneous Fee Schedule**  
**Fiscal Year 2025-26**

CPI% increase for FY 25/26

**2.128%**

**MISCELLANEOUS FEES:**

**2025-26**

Refrigeration Equipment, Install/Operate (initial)				\$341
Refrigeration Equipment, Install/Operate (renewal)				\$217
Repair Garages				\$154
Administration (OES)				\$154
Spraying or Dipping (initial)				\$404
Spraying or Dipping (renewal)				\$217
Tents/Canopy/Membrane Structures - Non High Fire Hazard Area (100 occupants)				\$154
Tents (all others)				\$404
Tire Storage				\$217
Wood Products				\$278
Hot Work and Cutting Operations (within occupancy and mobile)				\$217
Fireworks Stands/Booth Application Fee				\$186
Firework Stand/Storage/Display Inspection				\$142
Special Events Fire and Life Safety				
Cost Recovery/Miscellaneous:				
1,250-1500 GPM (16 hour maximum)				\$114
1,501-2000 GPM (16 hour maximum)				\$118
Pick-Up (16 hour maximum)				\$78
Works Comp.				Actual Cost
Rent: Private Organization (per hour)				\$0.20
Fire Reports				\$19
Street Spills				\$58 plus Actual Cost
<b>False Alarms (within a 12 month period at a single site) False alarms are not subject to COLA</b>				
False Alarms (first and second incident)				\$0
False Alarms (third thru fifth**)				\$67
False Alarms (sixth and subsequent**)				\$135
False Alarms (maximum fee per day)				\$337
<b>**If both Police and Fire respond to false alarm, only one charge shall be assessed per incident.</b>				
<b>PARKS, RECREATION &amp; COMMUNITY EVENTS</b>				
<b>Community Center, Multipurpose Room</b>				
Reservation and Cleaning Deposit				\$350
Cancellation Fee: Less than 10 Days of Rental				Forfeit of all rental fees
Cancellation Fee: More than 10 Days of Rental				\$175
Cancellation Fee: More than 30 Days of Rental				\$80
Rent: Private Organization (per hour)				\$100
Rent: Non-Profit/Senior Organization (per hour)				\$70
Rent: Private Organization (per day)				\$2,400
Rent: Non-Profit/Senior Organization (per day)				\$1,680
Facility Attendant, (per hour)				\$35
<b>Community Center, Multipurpose Room &amp; Evelyn Chambers Senior Room</b>				
Reservation and Cleaning Deposit				\$525
Cancellation Fee: Less than 10 Days of Rental				Forfeit Deposit
Cancellation Fee: More than 10 Days of Rental				\$175
Cancellation Fee: More than 30 Days of Rental				\$80
Rent: Private Organization (per hour)				\$140

**Miscellaneous Fee Schedule**  
**Fiscal Year 2025-26**

CPI% increase for FY 25/26

**2.128%**

**MISCELLANEOUS FEES:**

**2025-26**

Rent: Non-Profit/Senior Organization (per hour)					\$90
Rent: Private Organization (per day)					\$3,360
Rent: Non-Profit/Senior Organization (per day)					\$2,160
Facility Attendant, (per hour)					\$35
<b>Community Center, Evelyn Chambers Senior Room</b>					
Reservation and Cleaning Deposit					\$210
Cancellation Fee: Less than 10 Days of Rental					Forfeit of all rental fees
Cancellation Fee: More than 10 Days of Rental					\$105
Cancellation Fee: More than 30 Days of Rental					\$80
Rent: Private Organization (per hour)					\$75
Rent: Non-Profit/Senior Organization (per hour)					\$40
Rent: Private Organization (per day)					\$1,800
Rent: Non-Profit/Senior Organization (per day)					\$960
Facility Attendant, (per hour)					\$35
<b>Community Center, Jessie Frago or Andy Longinotti Meeting Rooms</b>					
Reservation and Cleaning Deposit					\$210
Cancellation Fee: Less than 10 Days of Rental					Forfeit of all rental fees
Cancellation Fee: More than 10 Days of Rental					\$105
Cancellation Fee: More than 30 Days of Rental					\$80
Rent: Private Organization (per hour)					\$65
Rent: Non-Profit/Senior Organization (per hour)					\$40
Rent: Private Organization (per day)					\$1,560
Rent: Non-Profit/Senior Organization (per day)					\$960
Facility Attendant, (per hour)					\$35
<b>Community Center, Kitchen</b>					
Reservation and Cleaning Deposit					\$210
Cancellation Fee: Less than 10 Days of Rental					Forfeit of all rental fees
Cancellation Fee: More than 10 Days of Rental					\$105
Cancellation Fee: More than 30 Days of Rental					\$80
Senior Citizen Groups with Kitchen (per hour)					\$40
Rent: Non-Profit/Senior Organization (per hour)					\$35
Senior Citizen Groups with Kitchen (per day)					\$960
Rent: Non-Profit/Senior Organization (per day)					\$840
<b>Table &amp; Chair Fees:</b>					
Table & Chair Set Up and Usage Fee					\$125
Table & Chair Set up and Usage Fee for Senior Citizen Organization					\$75
<b>Castle Youth Center</b>					
Birthday Party (2 hours) gym, game room & activity area					\$175
Gym Rental (per hour)					\$60
Facility Attendant, (per hour)					\$35
<b>Veterans Park Pavilion</b>					
Reservation and Cleaning Deposit					\$200
Cancellation Fee: Less than 10 Days of Rental					Forfeit of all rental fees
Cancellation Fee: More than 10 Days of Rental					\$75
Cancellation Fee: More than 30 Days of Rental					\$80
Atwater Resident Rental Fee with Kitchen					\$250

**Miscellaneous Fee Schedule**  
**Fiscal Year 2025-26**

CPI% increase for FY 25/26

**2.128%**

**MISCELLANEOUS FEES:**

**2025-26**

Senior/Civic/Schools/Non-Profit Organization with Kitchen					\$200
Osborn and Miyake Ball Field Tournament without Lights (per field per day)					\$175
Facility Attendant, (per hour)					\$35
<b>Bloss Grounds</b>					
Deposit					\$350
Private Party (2 hour minimum)					\$80 per hour
Non-Profit / Senior Group (2 hour minimum)					\$40 per hour
Facility Attendant, (per hour)					\$35
Photography Session (2 hour minimum) - <b>Exclusive Use Only</b>					\$30 per hour
<b>Bloss Library Museum</b>					
Private Usage					\$50 per hour
Non-Profit / Senior Group					No Charge
Facility Attendant, (per hour)					\$35
<b>Field Rentals</b>					
Osborn and Miyake Ball Field Deposit					\$210
Osborn and Miyake Ball Field Rental (per hour)					\$35
Osborn and Miyake Ball Field Rental with Lights (per hour)					\$40
Learn to Swim Program (parent & infant)					\$145
Osborn and Miyake Ball Field Tournament Field Preps (per prep per field per day)					\$75
Veterans Park Football Field Deposit					\$210
Veterans Park Football / Soccer Field, Youth Teams (per day)					\$125
Veterans Park Football Field, Adult Teams (per day)					\$150
Memorial Ball Field Deposit					\$200
Memorial Ball Field (per game)					\$75
Memorial Ball Field Prep					\$75
Memorial Ball Field Light Usage (per hour)					\$40
Joan Faul Soccer Field Deposit					\$210
Joan Faul Soccer Field 1 (per day)					\$100
Joan Faul Soccer Field 2 (per day)					\$100
Joan Faul Soccer Fields 1 & 2 (per day)					\$175
<b>Youth Recreation Programs</b>					
			<b>Resident</b>	<b>Non Resident</b>	
Osborn Park Tennis Court (per key for one year)			\$80	\$100	
Osborn Park Tennis Court (per key for six months)			\$40	\$50	
Youth Basketball (co-ed, boys and girls, grades K-12) (per player)			\$80	\$105	
Youth Indoor Soccer (per player)			\$75	\$95	
Summer Drop-in Program - Per Week					
Full Day - Per Week			\$90	\$115	
Youth Flag Football (per player)			\$75	\$95	
Youth Volleyball (per player)			\$85	\$105	
Summer Youth Camp (per camp)			\$50	\$70	
<b>Adult Recreation Programs</b>					
Men's Spring Softball			\$550	\$575	
Men's Summer Softball			\$550	\$575	
Men's Fall Softball			\$550	\$575	
Coed Spring Softball			\$550	\$575	

**Miscellaneous Fee Schedule**  
**Fiscal Year 2025-26**

CPI% increase for FY 25/26

**2.128%**

**MISCELLANEOUS FEES:**

**2025-26**

Vendor Fair Booth Rental (12x12)	\$550	\$575
Coed Fall Softball	\$550	\$575
Coed Winter Volleyball	\$425	\$450
Coed Summer Volleyball	\$425	\$450
Men's Volleyball	\$425	\$450
Women's Volleyball	\$425	\$450
Men's Summer Basketball League	\$650	\$675
Men's Winter Basketball League	\$650	\$675
<b>Other Recreation Programs</b>		
Misc. Recreation Classes & Events	\$10 - \$50	\$10 - \$50
Vendor Fair Booth Rental (12x12)	\$100	\$100
Christmas Parade Entry Fee	\$45	\$45
Christmas Parade Additional Horse Entry Fee (per horse)	\$5	\$5

**Miscellaneous Fee Schedule**  
**Fiscal Year 2025-26**

CPI% increase for FY 25/26

**2.128%**

**MISCELLANEOUS FEES:**

**2025-26**

<b>Sanitation</b>		
<b>Other/Additional Services/One-Time/Temporary</b>	<b>Billing Frequency</b>	
Single-Family & Multi-Family (2-4 units w/CARTS)		
Residential Large Item Pick-up - Includes up to two (2) Items	Per Occurrence	\$63
Restart of Services (Auto Resume Fee)	Per Occurrence	\$0
Cart Delivery	Per Occurrence	\$105
Cart Removal	Per Occurrence	\$0
Cart Exchange	Per Occurrence	\$79
Residential Cart Replacement Fee	Per Occurrence	\$79
Overloaded/Contamination Fee 1st Occurrence (any cart)	Per Occurrence	\$27
Overloaded/Contamination Fee 2nd Occurrence (any cart)	Per Occurrence	\$32
<b>Temporary Bins- Available to ALL Property Types</b>		
3 Cubic Yard Temporary Bin		
Delivery, Removal and up to 7 days rental	Per Bin	\$236
Each additional pickup	Per Occurrence	\$110
4 Cubic Yard Temporary Bin		
Delivery, Removal and up to 7 days rental	Per Bin	\$292
Each additional pickup	Per Occurrence	\$127
<b>Multi-Family (5+ units) ** Commercial -All ** Multi-Family (2-4 units)</b>		
<b>(Bin or Cart)</b>	<b>(Bin or Cart)</b>	<b>(Bin ONLY)</b>
Cart Contamination / Overloaded	Per Occurrence	\$27
Bin Contamination / Overloaded	Per Cubic Year	\$32
Special Services:		
Special Pick-Up up to 3 cubic yards	Each	\$218
Additional Standby and Loading Time	Per Hour	\$144
Large Venue Events (Non-City Events)	Per Occurrence	\$218
Other Services:		
Locking Bin, Lock on Gate, enclosure monthly fee	Per Lock, Per Month	\$47
Trip Charge/Dry Run	Per Occurrence	\$209
Restart of Services (Auto Resume Fee)	Per Occurrence	\$0
Setup Fee	Per Occurrence	\$0
Delivery Charge	Per Occurrence	\$47
Delivery Charge Commercial Carts	Per Occurrence	\$27
Removal	Per Occurrence	\$79
Exchange Fee	Per Occurrence	\$47
Stinger/Scout Service Fee	Per Bin, Per Service	\$39
Recycling Contamination Fee	Per Occurrence	\$45
Overage Fee	Per Occurrence	\$62
Roll-Off Containers billed on a per pull plus disposal fee		
10 Cubic Yd Container per pull	Per Haul	\$448
20 Cubic Yd Container per pull	Per Haul	\$464
30 Cubic Yd Container per pull	Per Haul	\$477
40 Cubic Yd Container per pull	Per Haul	\$488
Container Rental per day after 7 days	Per Day	\$18

**Miscellaneous Fee Schedule  
Fiscal Year 2025-26**

CPI% increase for FY 25/26

**2.128%**

**MISCELLANEOUS FEES:**

**2025-26**

Commercial and Multi-Family Rates (monthly):

Number of Pick Up(s) per week	1x	2x	3x	4x	5x	6x
<small>(Note: includes 32-Gallon Recycling and 32-Gallon Organics)</small>						
<b>Trash:</b>						
64- Gallon Cart	\$48.84	\$70.54	\$92.24	\$113.93	\$135.63	\$157.33
96- Gallon Cart		\$97.66	\$141.06	\$184.45	\$227.85	\$271.23
1 Cubic Yard Bin						\$471.94
2 Cubic Yard Bin	\$184.45	\$314.63	\$444.82	\$575.00	\$705.18	\$835.37
3 Cubic Yard Bin						\$1,052.34
4 Cubic Yard Bin	\$287.51	\$445.42	\$634.67	\$831.15	\$929.99	\$1,114.42
6 Cubic Yard Bin						\$1,301.25
2 Cubic Yard Compactor	\$489.00	\$844.00	\$1,120.00	\$1,555.00	\$1,911.00	\$2,266.00
3 Cubic Yard Compactor	\$637.00	\$1,082.00	\$1,526.00	\$1,970.00	\$2,414.00	\$2,859.00
6 Cubic Yard Compactor	\$1,067.00	\$1,708.00	\$2,298.00	\$2,722.00	\$3,074.00	\$3,538.00
<b>Recycling:</b>						
64- Gallon Cart	\$20.79	\$34.59	\$48.39	\$62.19	\$76.00	\$89.79
96- Gallon Cart	\$21.60	\$36.12	\$50.65	\$65.18	\$79.71	\$94.24
1 Cubic Yard Bin	\$61.95	\$110.38	\$158.81	\$207.25	\$255.67	\$304.11
2 Cubic Yard Bin	\$94.24	\$166.89	\$239.53	\$312.18	\$384.82	\$441.33
3 Cubic Yard Bin	\$110.38	\$207.25	\$279.90	\$352.54	\$433.26	\$522.05
4 Cubic Yard Bin	\$134.60	\$247.61	\$360.61	\$473.62	\$594.70	\$715.77
6 Cubic Yard Bin	\$174.96	\$344.47	\$489.76	\$651.20	\$812.64	\$974.07
2 Cubic Yard Compactor	\$243.00	\$441.00	\$640.00	\$838.00	\$1,036.00	\$1,191.00
3 Cubic Yard Compactor	\$287.00	\$551.00	\$750.00	\$948.00	\$1,168.00	\$1,411.00
6 Cubic Yard Compactor	\$463.00	\$926.00	\$1,323.00	\$1,763.00	\$2,204.00	\$2,645.00
<b>Organics: (Also includes :Green Waste &amp; Food Waste, Green Waste only, &amp; Food Waste only)</b>						
64-Gallon Cart	\$30.64	\$55.82	\$79.60	\$103.39	\$127.17	\$150.96
96-Gallon Cart	\$36.23	\$58.62	\$82.40	\$106.18	\$129.97	\$153.76
1 Cubic Yard Bin	\$110.15	\$180.34	\$264.28	\$348.23	\$432.18	\$516.13
2 Cubic Yard Bin	\$166.35	\$316.06	\$465.76	\$615.47	\$765.18	\$914.88
3 Cubic Yard Bin	\$229.31	\$439.18	\$649.05	\$858.92	\$1,068.78	\$1,278.66
4 Cubic Yard Bin	\$299.27	\$551.11	\$802.95	\$1,054.80	\$1,306.64	\$1,558.48
6 Cubic Yard Bin	\$425.19	\$809.95	\$1,194.71	\$1,579.46	\$1,964.22	\$2,348.98
<b>Push Rate Fee's (monthly):</b>						
	1	2	3	4	5	6
15 Feet	\$37.00	\$73.00	\$105.00	\$131.00	\$157.00	\$183.00
25 Feet	\$47.00	\$89.00	\$131.00	\$172.00	\$214.00	\$256.00
50 Feet	\$157.00	\$251.00	\$344.00	\$468.00	\$532.00	\$626.00
75 Feet	\$188.00	\$292.00	\$397.00	\$501.00	\$605.00	\$709.00
100 Feet	\$261.00	\$391.00	\$522.00	\$652.00	\$782.00	\$1,043.00



**CITY COUNCIL  
AGENDA REPORT**

**CITY COUNCIL**

Mike Nelson, Mayor  
Danny Ambriz                      Brian Raymond  
John Cale                              Kalisa Rochester

**MEETING DATE:** June 9, 2025  
**TO:** Mayor and City Council  
**FROM:** Anna Nicholas, Finance Director  
**PREPARED BY:** Anna Nicholas, Finance Director  
**SUBJECT:** **Resolutions Adopting the Fiscal Year 2025-26 Budget including Five-Year Capital Improvement Plan and Approving Fund Expenditures and Fund Transfers; Establishing Appropriations Limitations; and Amending Classification Plan and Adopting Salary Schedule A-26 Effective June 20, 2025 (City Manager/Executive Director Hoem, Human Resources Director Sousa, and Finance Director/Treasurer Nicholas)**

**RECOMMENDED COUNCIL ACTION**

Open the Public Hearing and receive any testimony given regarding the Fiscal Year 2025-26 Budget;

Close the Public Hearing;

Motion to adopt Joint Authority Resolution No. 3538-25, Resolution No. AFD 1-2025, and Resolution No. SA 2025-1 adopting the Fiscal Year 2025-26 budget, approving Fund Expenditures and Fund Transfers, and a Five-Year Capital Improvement Program with any modifications from the budget review and public hearing; to adopt Resolution No. 3539-25 establishing the Fiscal Year 2025-26 Appropriations Limitation; to adopt Resolution No. 3540-25 amending the City of Atwater Classification Plan and adopting Salary Schedule A-26, effective June 19, 2025; or

Motion to approve staff's recommendation as presented.

**I. BACKGROUND/ANALYSIS:**

City staff began the budget preparation process for Fiscal Year (FY) 2025-26 after the current Mid-Year Budget task had been completed. All the City's municipal departments have collectively worked to produce a budget that will maintain or improve the City's service levels while being mindful of operating with constrained resources. The FY 2025-26 Proposed Budget provides the City with the authority to use resources for the benefit of the community and is part of the annual budget process in which the City Council approves and adopts the budget by June 30th of each year. This action allows

for expending funds for the new fiscal year beginning July 1st. The FY 2025-26 Proposed Budget is drafted with estimates based on available data and known factors at the time the budget is prepared.

On May 27, 2025, a Budget Workshop was held to present the draft FY 2025-26 Proposed Budget that allowed for review of the estimated revenues and expenditures contained in the annual operating budget and Capital Improvement Plan. On May 31, 2025, the City conducted a Strategic Planning Workshop that provided additional opportunity for budgetary discussion and public comment. At the time the proposed budget is compiled for the upcoming fiscal year, early projections available are used for revenue and expense estimates. Knowing these estimates could change over the next several months, the City performs a mid-year review of the budget in which revisions to the early estimates can be made if needed. The preparation of the FY 2025-26 Proposed Budget utilized a hybrid approach of both zero-based budgeting and traditional budgeting methods, with the latter being the foremost method used for the development of the budget.

The budgeting process is a function carried out throughout the fiscal year and is a highly collaborative process among all municipal departments within the City of Atwater. City governments are not immune to external economic events such as price increases, as all departments have felt the impact of increased expenses on the department operating budgets. Sales tax revenue projections remain relatively flat in comparison to the previous few years. With this budget, City staff took a pragmatic approach to carefully allocating costs to appropriate funds and created a sensible and fiscally sustainable spending plan for the fiscal year. City Council will be adopting an updated strategic plan in the coming months which will help guide and facilitate the allocation of resources in future fiscal years.

**General Fund Overview:**

The FY 2025-26 Proposed Budget Revenue and Expenditure estimates are:

Fiscal Year 2025-26	
General Fund	
Revenues	\$ 20,649,606
Expenditures	\$ 21,869,088
Difference	\$ (1,219,482)
One-time Spending	\$ 809,000
	<b>\$ (410,482)</b>

The General Fund revenue and expenditure estimates are preliminary and will be monitored throughout the duration of the fiscal year. The City Council will be apprised

of any major changes in these estimates during the mid-year budget review process. At this time, the General Fund Revenue estimates are projected to be \$20,649,606 and the General Fund Expenditure estimates are projected to be \$21,869,088. Of the \$1,219,482, expenses that are greater than revenue estimates, \$809,000 is considered one-time costs and not recurring expenses and the breakdown is displayed here:

Fiscal Year 2025-26	
General Fund One Time Expenses	
Fire Truck Type I Pay off	\$634,000
Mower-Parks	\$ 50,000
Fire Station Building repairs	\$125,000
	\$809,000

The City could experience some cost savings that would help reduce some of the estimated expenses. At certain periods of time throughout fiscal years, there are vacancies for budgeted personnel that provide cost savings. In addition, the CalFIRE agreement may yield savings if the full agreement amount is not reached through the fiscal year. Should this scenario not be likely in the upcoming fiscal year, there is an appropriate undesignated balance in the General Fund to cover the structural deficit. However, this is an area of priority for strategic planning in which the ongoing revenues need to cover ongoing expenses in order to preserve the General Fund balance for necessary one-time costs, economic downturns, and other unforeseen events that could significantly impact the incoming revenue streams and outgoing costs of the City.

**General Fund Balance:**

By way of Resolution No. 3068-19, the City is required to keep ten percent of the estimated fiscal year General Fund expenditures in reserve. The FY 2025-26 budget meets this requirement. Additionally, this budget allows the City to meet the goal of twenty-five percent of the estimated expenditures for the General Fund to be reserved. The City will continue to work diligently on maintaining this elevated goal of ensuring twenty-five percent of estimated operating expenses are reserved for emergencies, while budgeting for service delivery with constrained resources. Based on the current fiscal year (2024-25) and the upcoming fiscal year (2025-26) estimates, the General Fund is projected to have a fund balance of \$14.9 million at June 30, 2026.

**Gas Tax Revenues:**

Fund 1011 and Fund 1018 are the associated funds for the Highway Users Tax Account “HUTA” and SB1-Road Maintenance Rehabilitation Account “RMRA”, respectively. Combined, these funds are commonly referred to as “Gas Tax” and

provide revenues to be spent on local streets and roads in the areas of operations and maintenance, street projects and other related costs. The estimates used for the FY 2025-26 budget year were released with Governor Newsom’s May Revise budget. The collective total estimate for the City of Atwater for FY 2025-26 is \$1,745,201 to be received during the fiscal year, a slight increase from the current FY 2024-25 revenue projections of \$1,670,089.

**Classification Plan/ Salary Schedule:**

The amended City of Atwater classification plan and salary schedule will be effective June 19, 2025, and includes a two percent cost of living adjustment for the Atwater Police Officer's Association bargaining group.

**CalPERS UAL:**

For FY 2025-26, the annual prepayment amount for all the tiers the City participates in is \$2,667,378. By paying the full amount in July, versus monthly payments, the City is able to save approximately 3% in cost which has been included in the budgeted amount. The City of Atwater has five plans with CalPERS. Each plan has a funded status and unfunded accrued liability (UAL), and is displayed in the chart below:

		Funded Status as of June 30, 2023	
		UAL	Funded Ratio
Miscellaneous		\$ 14,234,128	66.7
Miscellaneous Second Tier		\$ 46,300	83.4
PEPRA Miscellaneous		\$ 288,448	86.3
PEPRA Safety Police Plan		\$ 237,804	86.0
Safety Plan		\$ 16,025,413	68.4
		\$ 30,832,093	78.2
Overall funded status ratio for CalPERS 75% estimated June 30, 2024			
Source: www.calpers.ca.gov			

**Insurance Premiums:**

The City of Atwater is a member of the Central San Joaquin Valley Risk Management Authority, referred to as the ‘RMA’. The RMA is a joint powers authority which serves as the City’s insurance coverage for various coverage programs. In addition to pooled insurance rates, the RMA provides additional benefits to member cities, such as contract review, risk management training, and valuable employee safety training. The FY 2025-26 Proposed Budget includes a premium increase of approximately 16% from the prior fiscal year. The premium is paid through allocation of multiple funds. The total estimated contribution that has been included in the proposed budget is \$2,420,905, which is the total combined premium amount for the programs the City participates in.

**Capital Improvement Projects:**

The FY 2025-26 budget includes \$16,398,624 in Capital Improvement Program project expenses, planned in multiple funds. A full detailed listing of the projects has been summarized for easy access in the 'Capital Improvement Program' pages of the budget document.

**Fiscal Year 2025-26 Appropriations Limit "GANN Limit":**

The appropriations limitation for Fiscal Year 2025-26 is calculated to be \$66,711,927. The appropriations subject to the limitations are \$52,218,193, and therefore are under the appropriations limit and are not anticipated to exceed the appropriations limit. (Resolution No. 3539-25).

**Other Notable Items for FY 2025-26 Proposed Budget**

The proposed budget for FY 2025-26 includes funding to add (2) Part-time Community Service Officers, (2) Water Systems Operators, conversion of a part-time Building Maintenance Worker to a full-time position, and staffing reorganization in the Community Development Department. The budget includes funding to purchase a new mower for parks operations and to fully pay the purchase obligation for the City's new Type I fire engine.

**Looking forward and Items of Consideration:**

Sewer fund: in addition to ongoing operations and maintenance, this fund maintains debt service, and it is imperative to establish user fees to cover ongoing operations and maintenance and debt service. A sewer rate increase needs to be evaluated and if warranted, adopted to ensure debt service coverage while maintaining sufficient revenues to cover ongoing expenses. The CFD-Public Safety Fund is projected to run a deficit based on revenue and expense estimates; therefore, requiring a General Fund subsidy. The true cost of providing the public safety services is not being accounted for in this fund, as there are costs associated with centralized services and administration that the General Fund is paying for, in addition to the subsidized transfer that is expected to occur for FY 2025-26. Public Safety Transaction & Use Tax Fund has been balanced with estimated ongoing revenues and estimated ongoing expenses. Similar to the CFD Public Safety Fund, the Public Safety Transactions and Use Tax Fund does not capture the full costs of providing the services out of the fund. Further consideration needs to be given in the General Fund structural deficit, which in part is due to absorbing an estimated amount of costs for the CFD-Public Safety Fund. The current CalFIRE agreement includes a five percent cost escalator and the memorandum of understanding for the Atwater Police Officer's Association (POA) includes a two percent Cost of Live Adjustment (COLA). Of note, the POA agreement includes a two percent COLA effective 7/1/2026 which will be factored into the FY 2026-27 budgeted expenses. When growing services in one department of the City, full

consideration needs to be given to the true cost of the service to ensure the sustainability of all funding sources for the service(s). Additional items of consideration (such as General Fund Reserve Policy revision) were discussed at the strategic planning meeting held on May 31, 2025, and will be brought forward at a future date for formal adoption.

**Overall Proposed Budget:**

In summary, the Fiscal Year 2025-26 budget will allow for the City to adopt a spending plan for continuity of services beginning July 1, 2025. Budgets serve two primary purposes for local governments: a developed spending plan and a communication tool to convey the services and projects of the City’s operations. City staff have met these two objectives by estimating revenues and expenditures with available data to minimize any potential large fluctuations in resources balanced with service delivery, and by communicating the adopted priorities and projects of the City Council.

**II. FISCAL IMPACTS:**

The fiscal impact of the FY 2025-26 proposed budget will be an increase of funds due to estimated revenues/transfers-in across all funds in the amount of \$68,474,360, and a reduction in funds due to estimated expenses/transfers-out across all funds in the amount of \$85,169,612, of which \$16,398,624 has been identified as Capital Improvement Plan program costs.

Fiscal Year 2025-26	
<u>Projected Fiscal Impact All Funds</u>	
Revenue	<u>\$68,474,360</u>
CIP Expense	\$ 16,398,624
Operating Expense	<u>\$68,770,988</u>
Total Expenses	\$85,169,612

**III. LEGAL REVIEW:**

This item has been reviewed by the City Attorney's Office.

**IV. EXISTING POLICY:**

Should the proposed Fiscal Year 2025-26 budget not be adopted, a continuing resolution must be adopted to meet current or immediate obligations until the Fiscal Year 2025-26 budget is adopted by City Council.

**V. ALTERNATIVES:**

There are no suggested staff alternatives and staff recommendation is to approve the Fiscal Year 2025-26 proposed budget as presented. However, should the proposed Fiscal Year 2025-26 budget not be adopted, a continuing resolution must be adopted to meet current or immediate obligations until the Fiscal Year 2025-26 budget is adopted by the City Council.

**VI. INTERDEPARTMENTAL COORDINATION:**

The compilation of the City's Annual Budget involves coordinated efforts of all department directors and the City Manager.

**VII. PUBLIC PARTICIPATION:**

A Public Hearing Notice was published in the Merced Sun Star. Additionally, the public will have an opportunity to provide comment on this item prior to City Council action.

**VIII. ENVIRONMENTAL REVIEW:**

This item does not meet the definition of a "project" as defined under Section 21065 of the Public Resources Code in that it would not directly or foreseeable indirectly significantly impact the physical environment and therefore is not subject to analysis.

**IX. STEPS FOLLOWING APPROVAL:**

Following adoption of the Fiscal Year 2025-26 budget, the City Clerk will finalize the resolutions to include in the FY 2025-26 budget document. A copy of the budget document will be made available on the City's website. The FY 2025-26 budget is implemented from July 1, 2025, through June 30, 2026.

Submitted by:



---

Anna Nicholas, Finance Director

Submitted by:

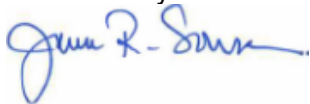

---

Jana Sousa, Human Resources Director

Submitted and Approved by:



Chris Hoem, City Manager

Attachments:

1. Joint Authority Resolution FY 25-26
2. FY 2025-26 Final Budget Book
3. Resolution Number 3539-25 Resolution
4. Resolution Number 3539-25 EXHIBIT A Appropriations Limitation FY 25-26
5. Resolution No. 3540-25 Amends Classification Plan and Adopts Salary Schedule A-26



## CITY OF ATWATER JOINT AUTHORITY RESOLUTION

**RESOLUTION NO. 3538-25  
RESOLUTION NO. AFD 1-2025  
AND  
RESOLUTION NO. SA 2025-1**

**A RESOLUTION OF THE CITY COUNCIL OF THE  
CITY OF ATWATER, BOARD OF DIRECTORS OF  
THE ATWATER FIRE PROTECTION DISTRICT,  
AND GOVERNING BOARD OF THE SUCCESSOR  
AGENCY TO THE ATWATER REDEVELOPMENT  
AGENCY ADOPTING THE 2025-26 FISCAL YEAR  
BUDGET, APPROVING FUND EXPENDITURES  
AND FUND TRANSFERS, AND 5-YEAR CAPITAL  
IMPROVEMENT PROGRAM**

**WHEREAS**, the City Manager/Executive Director has submitted to the City Council of the City of Atwater, the Board of Directors of the Atwater Fire Protection District, and the Governing Board of the Successor Agency to the Atwater Redevelopment Agency the 2025-26 Fiscal Year Budget; and

**WHEREAS**, it is the intention of the City Council of the City of Atwater, the Board of Directors of the Atwater Fire Protection District, and the Governing Board of the Successor Agency to the Atwater Redevelopment Agency to adopt the proposed budget as submitted by the City Manager/Executive Director.

**NOW, THEREFORE, BE IT RESOLVED** that the 2025-26 Fiscal Year Budget for the City of Atwater, the Atwater Fire Protection District, and the Successor Agency to the Atwater Redevelopment Agency as presented on June 9, 2025 (incorporated by reference herein) is hereby approved by the City Council of the City of Atwater, the Board of Directors of the Atwater Fire Protection District, and the Governing Board of the Successor Agency to the Atwater Redevelopment Agency.

**BE IT FURTHER RESOLVED** that a copy of the approved 2025-26 Fiscal Year Budget for the City of Atwater, Atwater Fire Protection District, and the Successor Agency to the Atwater Redevelopment Agency shall be available in the office of the City Manager and the City Clerk.

The foregoing resolution is hereby adopted this 9<sup>th</sup> day of June 2025.

**AYES:**

**NOES:**

**ABSENT:**

**APPROVED:**

\_\_\_\_\_  
**MIKE NELSON, MAYOR**

**ATTEST:**

\_\_\_\_\_  
**KORY J. BILLINGS, CITY CLERK**

# CITY OF ATWATER



## FISCAL YEAR BUDGET 2025-2026

July 1, 2025 – June 30, 2026

*Adopted on June 9, 2025*

# CITY OF ATWATER

A General Law City

*~Incorporated 1922~*

## City Council

Mike Nelson, Mayor

John Cale, Council Member, District 1

Kalisa Rochester, Council Member, District 2

Danny Ambriz, Council Member, District 3

Brian Raymond, Council Member, District 4

## Executive Management Team

Chris Hoem, City Manager

Robert Ayuso, Battalion Chief, CAL FIRE

Richard McEachin, Police Chief

Anna Nicholas, Finance Director

Jana Sousa, Human Resources Director

Frank Splendorio, contract City Attorney, Best Best & Krieger

Justin Vinson, Public Works Director

Blank Page

# CITY OF ATWATER

## Elected Representatives

**John Cale**  
Council Member  
(District 1)



**Kalisa Rochester**  
Council Member  
(District 2)



**Mike Nelson**  
Mayor



**Danny Ambriz**  
Council Member  
(District 3)



**Brian Raymond**  
Mayor Pro Tem  
(District 4)



City of Atwater  
Office of the City Manager  
1160 Fifth Street  
Atwater, California 95301  
(209) 357-6300  
[www.atwater.org](http://www.atwater.org)



# CITY OF ATWATER ORGANIZATIONAL CHART 2025

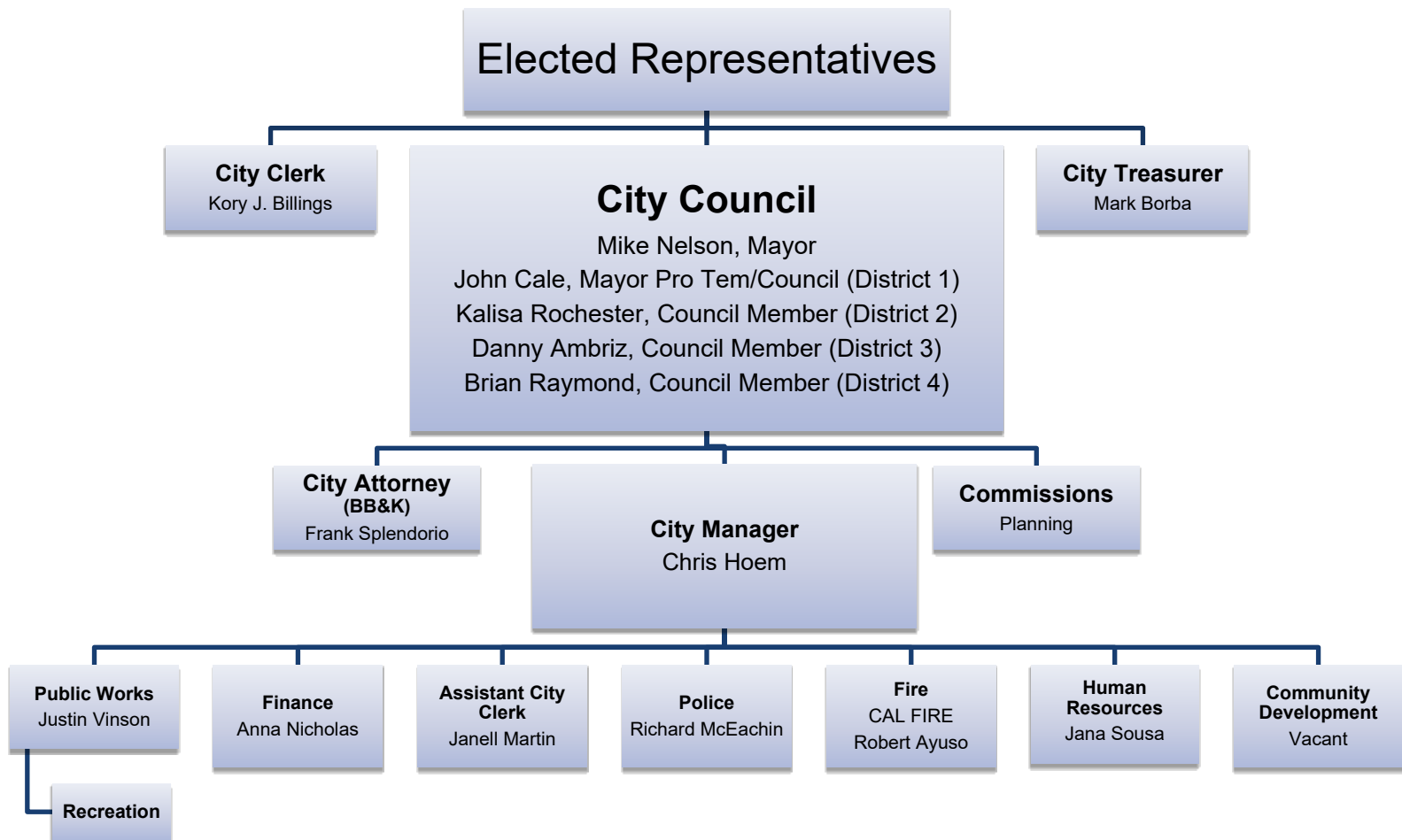

**Council Committees:** Audit & Finance,  
Citizens Oversight for Public Safety Transaction and Use Tax



## **TABLE OF CONTENTS**

---

### **Introduction**

City Manager's Budget Message.....	1
City Mission Statement .....	4

### **Fund Summaries**

Personnel by Department.....	6
General Fund Revenue History .....	7
General Fund Expenditure History .....	7
General Fund - Fund Balance History .....	8
Fund Balance Projection .....	9

### **General Fund Revenue**

General Fund Revenue .....	11
----------------------------	----

### **General Fund Expenditures**

Mayor and City Council.....	15
City Administration/City Clerk .....	17
Finance.....	19
Human Resources .....	21
City Treasurer.....	23
Non-Departmental .....	24
Police.....	25
Fire .....	32
Community Development .....	34
Recreation .....	38
Community Events .....	42
Public Works - Parks Operations.....	44
Miscellaneous.....	46

### **Other Funds Revenue and Expenditures**

General Fund Capital Projects .....	48
Public Safety Transactions and Use Tax Fund .....	50
Measure V Fund .....	53
Measure V 20% Alternative Fund.....	54
Abandoned Vehicle Program Fund .....	55

Measure V Fund Regional Fund.....	56
ARPA-American Rescue Plan Act Fund.....	57
Gas Tax/Street Improvement Fund .....	59
Local Transportation Fund.....	62
Traffic Circulation Fund .....	63
RSTP – Regional Surface Transportaion Program Fund .....	64
SB1 – Road Maintenance and Rehabilitation RMRA Fund .....	65
Parks and Recreation Fund.....	66
General Plan Update / Housing Element Update .....	67
CDBG and Home Grants Fund.....	68
Police Facility Impact Fees Fund.....	70
Fire Facility Impact Fees Fund .....	71
Government Building Facility Fund.....	72
Pension Rate Stabilization Trust Fund .....	73
Maintenance Districts Fund .....	74
Community Facilities Districts Fund-Police Field Operations .....	75
Water Enterprise Funds.....	77
Wastewater Enterprise Funds .....	81
Sanitation Enterprise Fund .....	87
Internal Services Fund-City Buildings and Equipment Maintenance .....	89
Employee Benefits Fund .....	95
Risk Management Fund .....	97
Information Technology Fund.....	98
Successor Agency to the Atwater Redevelopment Agency .....	99
5-yr Capital Improvement Program .....	101
Debt Service .....	106
Interfund Transfers .....	108

**Supplemental**

Resolution No. 3068-19



# City of Atwater

---

OFFICE OF THE CITY MANAGER  
1160 FIFTH STREET  
ATWATER, CA 95301  
(209) 357-6300

## City Manager's Budget Message

### **Honorable Mayor, City Councilmembers, and the City of Atwater:**

I am pleased to present the City of Atwater's Budget for Fiscal Year 2025–26. This document represents more than just financial planning—it is a statement of priorities, a tool for accountability, and a reflection of our community's ongoing commitment to responsible governance. Included in this year's budget package are the City's Operating Budget and the Five-Year Capital Improvement Plan (CIP).

This budget has been developed during a period of relative economic steadiness, yet one that still demands thoughtful stewardship. Although general revenues remain mostly flat, our team has made meaningful progress in reducing the City's structural deficit by approximately one half. We have achieved this not through short-term fixes, but through the deliberate alignment of recurring expenditures with sustainable revenue sources. We are proud to report that all remaining ARPA (American Rescue Plan Act) funds have been fully obligated and directed toward one-time, strategic investments consistent with Council priorities.

### **Economic Outlook and Revenue Trends**

Atwater remains highly reliant on sales tax revenue, particularly from commercial activity along the State Route 99 corridor. We recognize the vulnerabilities that come with this dependence, especially as consumer behavior continues to evolve post-pandemic. While revenues have stabilized, they have not increased significantly. This reality reinforces the importance of

renewed attention to local economic development, business attraction, and retail retention strategies.

### **Strategic Focus and Fiscal Responsibility**

The FY 2025–26 budget marks a continued pivot toward long-term financial resilience. Over the past year, we have begun laying the groundwork for this through structural improvements and operational efficiencies. While we have not eliminated the structural deficit entirely, we have narrowed it significantly. Our efforts have included:

- Reassessing department budgets for cost-efficiency
- Making data-informed adjustments to service delivery
- Continuing our commitment to conservative revenue projections
- Enhancing fiscal discipline across departments

As we move forward, our guiding principles remain unchanged: preserve service levels, maintain a strong and professional workforce, and invest wisely in Atwater’s future.

### **Policy Direction and Planning Framework**

This year presents an opportunity to build upon the City’s recent Strategic Plan workshop (held on May 31, 2025) by developing goals tailored to key objectives, such as:

- Economic Development
- Public Safety and Stability
- Financial Solvency
- Transparency in Communication
- Improving Quality of Life

These goals will inform a policy-based budget framework that ensures alignment between City Council priorities and departmental activities. A continued emphasis on financial transparency will support both Council oversight and public trust. The updated Strategic Plan 2025-2030 is anticipated to be presented to Council by July 2025.

### **Looking Ahead: Fiscal Recovery and Resilience**

Although the City is now in a more stable financial position than it was a year ago, much work remains. To continue moving toward a structurally balanced General Fund, we will complete the following strategic efforts that are currently underway:

- Completion of a comprehensive fee and rate studies to ensure cost recovery
- Updates to development impact fees to support growth-related infrastructure
- Citywide cost allocation plan revisions to improve transparency
- Evaluation of revenue enhancement opportunities
- Proactive investment management strategies

### **Closing Thoughts**

This budget represents progress. It is the result of difficult but necessary decisions, detailed analysis, and a shared commitment to improving the financial health of our City. I want to thank the City Council for its leadership and clear direction throughout the budget process. I also extend my gratitude to City staff, particularly the Finance Department, for their diligence and professionalism in preparing this comprehensive budget package. Lastly, I want to show appreciation for the many ideas and suggestions that our public stakeholders and community have graciously shared with us.

Together, with continued focus, strategic investment, and community engagement, Atwater is building a more resilient future.

Respectfully submitted,

---

Chris Hoem  
City Manager



## Mission, Vision and Core Values

The purpose of establishing the City's Mission, Vision and Core Values is to clearly define why the City was incorporated, how the City Council envisions its future, and to what principles Council and Staff will adhere as part of conducting its business.

### Our Mission

---

***The Mission of the City of Atwater is to provide high quality, professional services and a safe family-oriented community where our residents may thrive.***

### Our Vision

---

***The City of Atwater is a regional leader in sustainable development offering a safe and welcoming community with a thriving downtown and stable economy that supports our growing population.***

### Our Core Values

---

*Integrity  
Collaboration  
Transparency  
Diversity*

*Respect  
Customer Service  
Innovation  
Responsiveness*

# Summary Information



# City of Atwater

## Fiscal Year 2025-26 Budget

### PERSONNEL BY DEPARTMENT

Department	Position	2022-23	2023-24	2024-25	2025-26
Administration	City Manager	1.00	1.00	1.00	1.00
	Assistant City Clerk/Records Coordinator	1.00	1.00	1.00	1.00
	Executive Assistant	0.00	0.00	1.00	1.00
	Administrative Assistant I/II	0.00	2.00	1.00	0.00
		2.00	4.00	4.00	3.00
Community Development	Deputy City Manager/Community Development Director	0.00	0.00	1.00	0.00
	Community Development Director	1.00	1.00	0.00	1.00
	City Engineer	0.00	1.00	1.00	1.00
	Chief Building Official/Fire Code Official	1.00	1.00	1.00	1.00
	Civil Engineering Assistant	1.00	1.00	1.00	1.00
	Senior Planner	1.00	1.00	1.00	1.00
	Assistant Planner	0.00	0.00	1.00	0.00
	Planning Technician	0.00	0.00	0.00	1.00
	Executive Assistant	1.00	1.00	1.00	1.00
	Project Accountant/Successor Agency Assistant	1.00	1.00	1.00	1.00
	Building Permit Technician I/II	1.00	1.00	1.00	2.00
	Administrative Assistant I/II	3.50	2.00	2.00	1.00
		10.50	10.00	10.00	11.00
Finance	Finance Director	1.00	1.00	1.00	1.00
	Finance Analyst - Special Projects ( <i>part-time position</i> )	0.00	0.50	0.50	0.50
	Finance Operations Manager	1.00	1.00	1.00	1.00
	Accountant I/II	1.00	1.00	2.00	2.00
	Accounting Technician	2.00	2.00	2.00	2.00
	Account Clerk I/II	3.50	4.00	4.00	4.00
	8.50	9.50	10.50	10.50	
Human Resources	Human Resources Director	1.00	0.00	1.00	1.00
	Human Resources Manager	0.00	1.00	0.00	0.00
	Human Resources Analyst	1.00	1.00	1.00	2.00
	Human Resources Technician I/II	3.00	3.00	3.00	1.00
	Human Resources Assistant	0.00	0.00	0.00	1.00
	5.00	5.00	5.00	5.00	
Police	Police Chief	1.00	1.00	1.00	1.00
	Police Lieutenant	1.00	1.00	1.00	1.00
	Police Sergeant	5.00	5.00	5.00	5.00
	Police Corporal	0.00	2.00	0.00	0.00
	Police Officer Recruit / Police Officer	21.00	19.00	19.00	19.00
	Police Administrative Supervisor	1.00	1.00	0.00	0.00
	Executive Assistant	0.00	0.00	1.00	1.00
	Public Safety Communications Supervisor	0.00	0.00	1.00	1.00
	Public Safety Dispatcher	6.00	7.00	6.00	6.00
	Public Safety Records Supervisor	0.00	0.00	1.00	1.00
	Police Clerk I/II	2.00	2.00	2.00	2.00
	Code Enforcement Manager	1.00	1.00	1.00	1.00
	Code Enforcement Officer	1.00	2.00	1.00	1.00
	Community Services Officer ( <i>includes part-time positions</i> )	2.00	2.00	1.00	2.00
	41.00	43.00	40.00	41.00	
Public Works	Public Works Director	1.00	1.00	1.00	1.00
	Public Works Superintendent	1.00	1.00	1.00	1.00
	Sewer Division Supervisor	1.00	1.00	1.00	1.00
	Executive Assistant	1.00	1.00	1.00	1.00
	Administrative Assistant I	1.00	1.00	1.00	1.00
	Recreation Supervisor	0.50	1.00	1.00	1.00
	Recreation Coordinator	0.00	1.00	1.00	1.00
	Senior Recreation Leader ( <i>part-time position</i> )	0.50	0.00	0.00	0.00
	Recreation Leader ( <i>part-time position</i> )	4.00	4.00	4.00	2.50
	Events Coordinator	0.50	0.50	1.00	0.00
	Administrative Assistant I/II	0.50	1.00	0.00	0.00
Public Works (cont.)	Systems Technician	1.00	1.00	1.00	1.00
	Streets & Parks Division Supervisor	1.00	1.00	1.00	1.00
	Streets Maintenance Worker I/II ( <i>includes part-time position</i> )	4.50	4.50	4.50	4.50
	Parks Maintenance Worker I ( <i>includes part-time position</i> )	4.50	4.50	4.50	4.50
	Water Division Supervisor	1.00	1.00	1.00	1.00
	Water Systems Pump Operator	1.00	1.00	1.00	1.00
	Water Systems Operators I/II	6.00	6.00	6.00	8.00
	Sewer Maintenance Worker I/II	8.00	8.00	8.00	8.00
	Building Maintenance Worker I ( <i>includes part-time position</i> )	1.50	1.50	1.50	2.00
	Mechanic I/II	2.00	2.00	2.00	2.00
	41.50	43.00	42.50	42.50	
	<b>GRAND TOTAL</b>	<b>108.5</b>	<b>114.5</b>	<b>112.0</b>	<b>113.0</b>

# City of Atwater

## Fiscal Year 2025-26 Budget

### GENERAL FUND REVENUE HISTORY

Fiscal Years 2018-19 through projected 2025-26

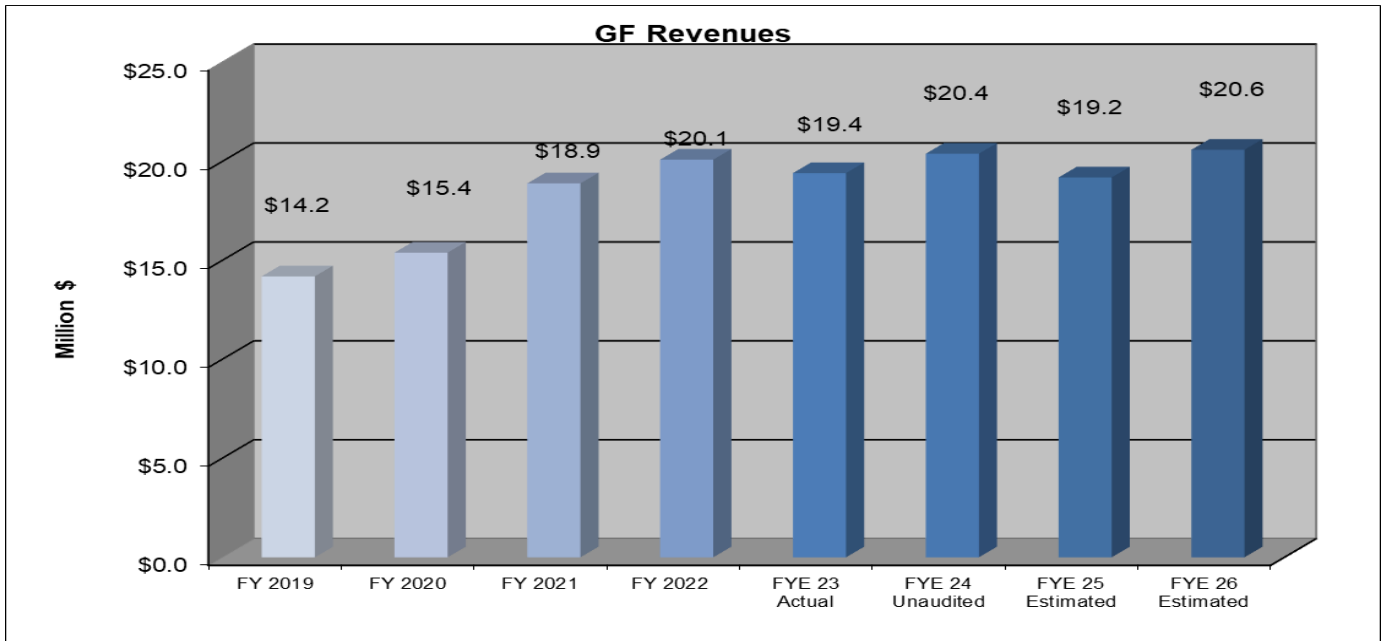

### GENERAL FUND EXPENDITURE HISTORY

Fiscal Years 2018-19 through projected 2025-26

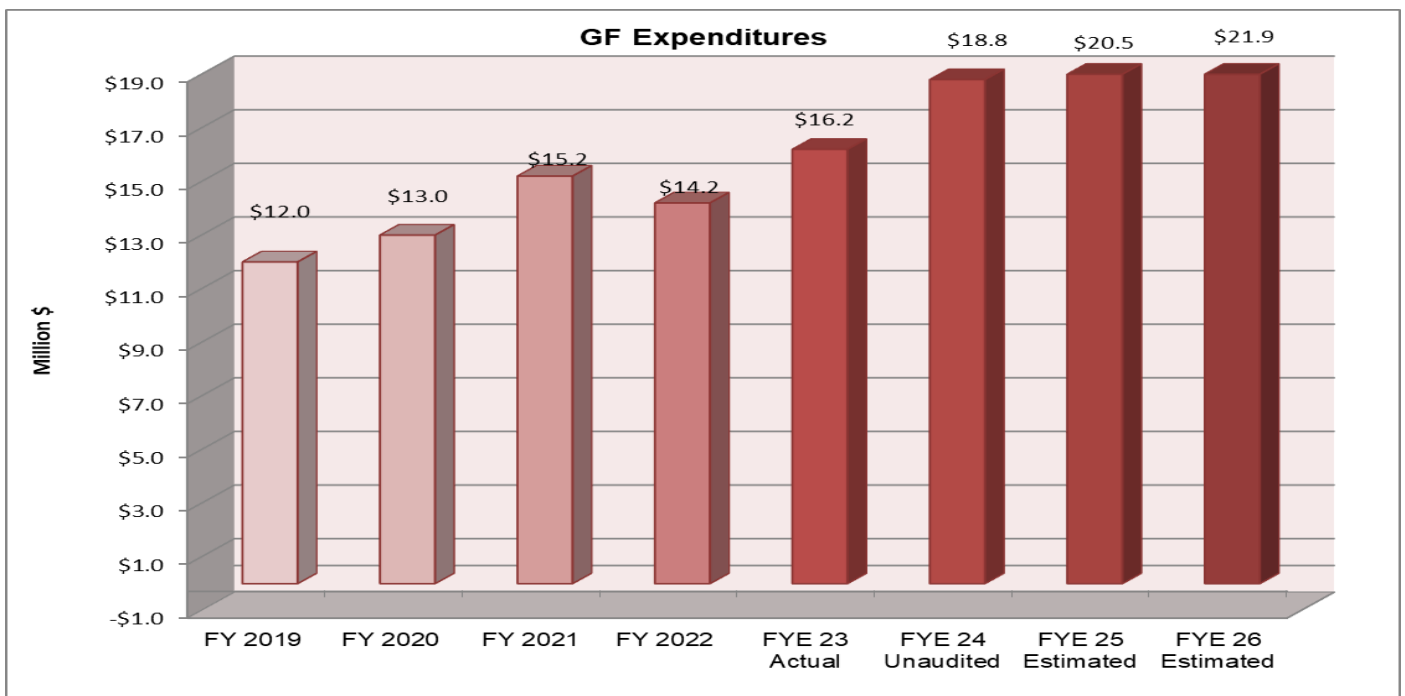

# City of Atwater

## Fiscal Year 2025-26 Budget

### General Fund Expenditures by Department

<b>GENERAL FUND EXPENDITURE SUMMARY</b>			
	<b>FY 2023-24 Unaudited</b>	<b>FY 2024-25 Current Budget</b>	<b>FY 2025-26 Proposed Budget</b>
<b>Department</b>			
City Council	\$20,130	\$25,700	\$71,200
City Administration / City Clerk	776,485	837,936	698,815
Finance	1,123,906	1,455,044	1,513,264
Human Resources	664,013	819,619	840,375
City Treasurer	2,728	3,848	3,149
Non-Departmental Misc.	2,715,408	2,735,827	2,753,252
Police	6,013,491	6,817,112	6,786,059
Fire	3,255,915	3,138,423	4,372,597
Community Development	2,140,049	2,507,136	2,471,914
Recreation	484,922	604,514	541,416
Community Events	69,502	112,269	13,300
Parks	687,206	773,266	785,198
Operating Transfers Out	952,884	917,640	1,018,549
<b>Total Expenditures</b>	<b>\$18,906,639</b>	<b>\$20,748,335</b>	<b>\$21,869,088</b>

### General Fund Balance History

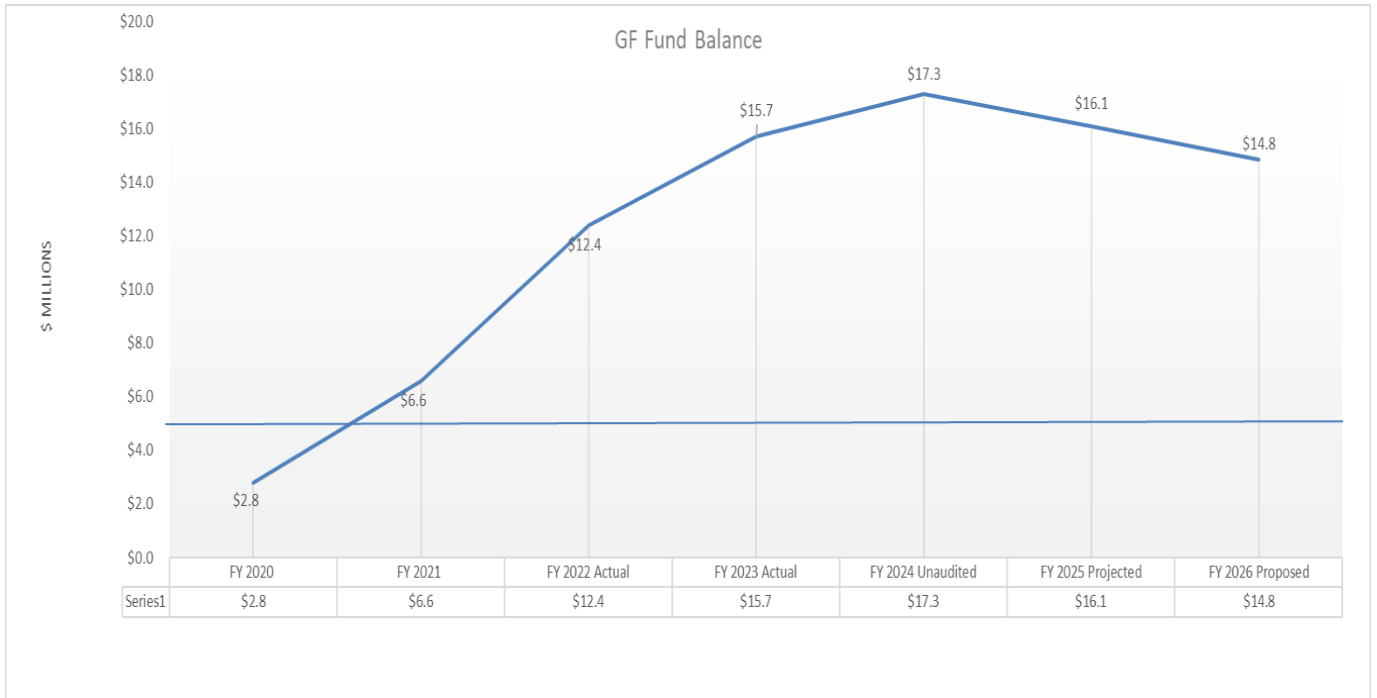

# City of Atwater

## Fiscal Year 2025-26 Budget

### Projected Fund Balances

FUND #	FUND DESCRIPTIONS	FY 23/24 Budget		FY 24/25 Budget		FY 25/26 Budget		
		Unaudited						
		Projected Fund Balance 6/30/2024	Revenue / Transfers IN	Expenditures / Transfers OUT	Projected Fund Balance 6/30/2025	Revenue / Transfers IN	Expenditures / Transfers OUT	Projected Fund Balance 6/30/2026
0001	<b>GENERAL FUND</b>	\$ 17,334,682	\$ 19,564,083	\$ 20,698,335	\$ 16,200,430	\$20,649,606	\$ 21,869,088	\$ 14,980,948
	25% General Fund Reserve Goal =	\$ (4,705,237)			\$ (5,174,584)			\$ (5,467,272)
	<b>Reserve General Fund- Unassigned Fund Bal</b>	<b>\$ 12,629,445</b>			<b>\$ 11,025,846</b>			<b>\$ 9,513,676</b>
	<b>GEN FUND BALANCE NO RESERVE SET ASIDE</b>	<b>\$ 17,334,682</b>			<b>\$ 16,200,430</b>			<b>\$ 14,980,948</b>
<b>NON-GENERAL FUNDS:</b>								
0003	General Fund Capital	\$ (34,837)	\$ 3,305,137	\$ 3,305,137	\$ (34,837)	\$ 2,598,890	\$ 2,598,890	\$ (34,837)
0004	Public Safety Transactions and Use Tax	\$ 3,072,498	\$ 5,115,700	\$ 5,856,701	\$ 2,331,497	\$ 5,289,315	\$ 5,289,338	\$ 2,331,474
0007	Measure V Fund	\$ 5,311,256	\$ 801,000	\$ 2,833,707	\$ 3,278,549	\$ 820,000	\$ 1,637,567	\$ 2,460,982
0008	Measure V 20% Alternative Modes	\$ 915,757	\$ 196,000	\$ 423,749	\$ 688,008	\$ 196,000	\$ 391,796	\$ 492,212
0009	Abandoned Vehicle Abatement Fund	\$ 363	\$ 29,716	\$ 29,765	\$ 314	\$ 30,958	\$ 30,948	\$ 324
0010	Measure V Regional Fund	\$ (120,842)	\$ 2,579,834	\$ 2,350,000	\$ 108,992	\$ 2,350,000	\$ 2,350,000	\$ 108,992
1005	Police Grant Fund	\$ 101,880	\$ 52,682	\$ 52,682	\$ 101,880	\$ -	\$ -	\$ 101,880
1010	ARPA - American Rescue Plan Act	\$ 2,756,108	\$ -	\$ 2,676,306	\$ 79,802	\$ -	\$ 165,566	\$ (85,764)
1011	Gas Tax Fund	\$ 156,642	\$ 1,490,317	\$ 1,489,965	\$ 156,994	\$ 1,501,415	\$ 1,501,617	\$ 156,792
1013	Local Transportation Fund	\$ 588,849	\$ -	\$ 394,828	\$ 194,021	\$ 1,000	\$ 394,828	\$ (199,807)
1015	Traffic Circulation Facilities Fund	\$ 1,545,572	\$ -	\$ -	\$ 1,545,572	\$ 8,676	\$ 184,000	\$ 1,370,248
1016	Applegate Interchange Fund	\$ 774,063	\$ -	\$ -	\$ 774,063	\$ -	\$ -	\$ 774,063
1017	RSTP - Regional Surf. Trans. Program Fund	\$ 2,691,316	\$ 449,743	\$ 2,918,211	\$ 222,848	\$ 5,000	\$ 2,430,350	\$ (2,202,502)
1018	SB1 - Road Maint & Rehab RMRA Fund	\$ 2,416,517	\$ 801,841	\$ 3,120,236	\$ 98,122	\$ 865,088	\$ 672,583	\$ 290,627
1020	Parks & Recreation Fund	\$ 1,946,857	\$ 17,674	\$ 600,000	\$ 1,364,531	\$ 17,674	\$ 400,000	\$ 982,205
1021	Parks Grant Fund	\$ -	\$ -	\$ -	\$ -	\$ -	\$ -	\$ -
1040	General Plan Housing Element Fund	\$ (10,800)	\$ 75,394	\$ 89,200	\$ (24,606)	\$ 25,394	\$ 14,594	\$ (13,806)
1041	General Plan Update Fund	\$ 1,901,195	\$ -	\$ 142,000	\$ 1,759,195	\$ -	\$ 1,681,148	\$ 78,047
1055	Neighborhood Stabilization Fund	\$ 229,201	\$ -	\$ -	\$ 229,201	\$ -	\$ -	\$ 229,201
1059-1080	Housing Grant Funds	\$ 999,142	\$ 949,757	\$ 949,257	\$ 999,642	\$ 302,504	\$ 658,408	\$ 643,738
1091	Police Facility Impact Fee Fund	\$ 195,823	\$ 4,500	\$ -	\$ 200,323	\$ 4,500	\$ -	\$ 204,823
1093	Fire Facility Impact Fee Fund	\$ 270,581	\$ 4,340	\$ 170	\$ 274,751	\$ 4,140	\$ 170	\$ 278,721
1095	Government Building Facility Tax	\$ 288,991	\$ 4,500	\$ -	\$ 293,491	\$ 4,500	\$ -	\$ 297,991
4020	Performance Bond Trust	\$ 108,704	\$ -	\$ -	\$ 108,704	\$ -	\$ -	\$ 108,704
4030	Narcotics Program Trust	\$ 2,152	\$ -	\$ -	\$ 2,152	\$ -	\$ -	\$ 2,152
4080	Pension Rate Stabilization - 115 Trust	\$ 514,432	\$ 50,000	\$ -	\$ 564,432	\$ 50,000	\$ -	\$ 614,432
4090	CFD No. 1 Trust	\$ 135,862	\$ 400	\$ -	\$ 136,262	\$ -	\$ -	\$ 136,262
5001-5055	Maintenance Districts	\$ 1,246,190	\$ 347,369	\$ 443,897	\$ 1,149,662	\$ 347,369	\$ 433,641	\$ 1,063,390
5050	CFD Districts - Police & Fire	\$ 90,962	\$ 835,065	\$ 800,279	\$ 125,748	\$ 883,081	\$ 882,838	\$ 125,991
6000-6006	Water Enterprise Fund	\$ 22,982,390	\$ 8,256,750	\$ 11,865,330	\$ 19,373,810	\$ 8,486,500	\$ 7,335,430	\$ 20,524,880
6007	Water - 1,2,3 - TCP Fund	\$ 39,289,699	\$ 25,000	\$ 2,149,640	\$ 37,165,059	\$ 25,000	\$ 1,500,000	\$ 35,690,059
6010-6015	Wastewater Enterprise Fund	\$ 18,703,504	\$ 12,400,118	\$ 18,274,505	\$ 12,829,117	\$12,408,624	\$ 21,311,560	\$ 3,926,181
6020	Sanitation Enterprise Fund	\$ 2,909,359	\$ 4,706,000	\$ 4,924,147	\$ 2,691,212	\$ 5,048,042	\$ 5,021,155	\$ 2,718,099
7000	Internal Services Fund (Bldg / Equip)	\$ 1,408,181	\$ 1,939,886	\$ 1,996,097	\$ 1,351,970	\$ 1,897,004	\$ 1,905,516	\$ 1,343,458
7001	ISF Equipment/Bldg Replacement Fund	\$ 195,959	\$ 100,000	\$ -	\$ 295,959	\$ 100,500	\$ -	\$ 396,459
7010	Employee Benefits Fund	\$ 784,001	\$ 1,003,097	\$ 1,003,200	\$ 783,898	\$ 1,100,200	\$ 1,058,200	\$ 825,898
7020	Risk Management Fund	\$ 935,057	\$ 2,541,858	\$ 2,520,104	\$ 956,811	\$ 2,572,406	\$ 2,571,406	\$ 957,811
7030	Information Technology Fund	\$ 681,252	\$ 782,318	\$ 782,317	\$ 681,253	\$ 880,975	\$ 878,975	\$ 683,253
	<b>Total</b>	<b>\$ 133,318,518</b>	<b>\$ 68,430,079</b>	<b>\$ 92,689,766</b>	<b>\$ 109,058,831</b>	<b>\$68,474,360</b>	<b>\$ 85,169,612</b>	<b>\$ 92,363,579</b>

\* Some fund balance negatives are due to encumbrances in two fiscal years/not actuals spent

# General Fund Revenues

# City of Atwater

## Fiscal Year 2025-26 Budget

Account Number	Description	FY 2023-24 Unaudited	FY 2024-25 Amended Budget as of 3/24/25	FY 2025-26 BUDGET
<b>0001</b>	<b>General Fund Revenues</b>			
0001-0000-1031	Sales & Use Tax	\$ 4,522,933	\$ 4,291,901	\$ 4,520,134
0001-0000-1032	Sales & Use Tax-Public Safety	\$ 179,282	\$ 192,000	\$ 203,000
0001-0000-1041	Business License Tax	\$ 237,083	\$ 230,000	\$ 240,000
0001-0000-1049	SB 1186 Fees-Business License	\$ 4,746	\$ 3,600	\$ 4,000
0001-0000-1051	Franchise Tax	\$ 714,781	\$ 640,000	\$ 737,064
0001-0000-1100	Prop Tax In Lieu Veh Lic Fee	\$ 3,851,288	\$ 4,060,000	\$ 4,204,937
0001-0000-1101	Property Tax, Current Secure	\$ 2,693,436	\$ 2,917,467	\$ 2,906,500
0001-0000-1102	Property Tax, Current Unsecure	\$ 202,926	\$ 212,466	\$ 219,105
0001-0000-1103	Property Tax, Prior Secured	\$ -	\$ 300	\$ 200
0001-0000-1104	Property Tax, Prior Unsecure	\$ 5,520	\$ 5,000	\$ 5,000
0001-0000-1105	Property Tax, Supplemental	\$ 60,285	\$ 35,000	\$ 60,000
0001-0000-1106	Property Tax Miscellaneous	\$ 16,570	\$ 10,000	\$ 16,000
0001-0000-1115	Property Tax, Homeowner Exempt	\$ 19,145	\$ 18,000	\$ 19,000
0001-0000-1117	Prop Tax Other In-Lieu Housing	\$ 2,369	\$ 2,000	\$ 2,000
0001-0000-1121	Transient Occupancy Tax	\$ 51,276	\$ 49,000	\$ 52,000
0001-0000-1161	Documentary Stamp Tax	\$ 66,433	\$ 90,000	\$ 70,000
0001-0000-2082	Other Licenses And Permits	\$ 1,484	\$ -	\$ 1,000
0001-0000-3012	SJVAPCD Grant	\$ 20,000	\$ -	
0001-0000-3110	Motor Vehicle In-Lieu Fee	\$ 39,219	\$ 37,000	\$ 50,000
0001-0000-3175	Statutory Pass-Through Revenue	\$ 142,199	\$ 90,000	\$ 140,000
0001-0000-3176	RDA Residuals (COA)	\$ 555,307	\$ 150,000	\$ 560,000
0001-0000-3177	RDA Residuals (COA Fire Dept)	\$ 182,836	\$ 100,000	\$ 190,000
0001-0000-4021	Sale Of Maps And Copies	\$ 73	\$ 2,000	\$ 1,000
0001-0000-4141	Admin Fees, Streets - Internal Service Operations	\$ 63,649	\$ 80,135	\$ 78,272
0001-0000-4142	Admin Fees, Water - Incl. Internal Service Operations & Salary Alloc.	\$ 1,389,343	\$ 1,469,431	\$ 1,520,376
0001-0000-4143	Admin Fees, Sanitation- Incl. Internal Service Operations & Salary Alloc.	\$ 836,818	\$ 933,898	\$ 868,453
0001-0000-4144	Admin Fees, Sewer - Incl. Internal Service Operations & Salary Alloc.	\$ 1,246,188	\$ 1,308,044	\$ 1,380,921
0001-0000-4145	Admin Fees, Maintenance Dist - Salary Alloc.	\$ 71,784	\$ 70,996	\$ 60,574
0001-0000-4149	Admin Fees, Successor Agency	\$ 29,422	\$ 29,422	\$ 29,422
0001-0000-5038	Forfeits	\$ 6,702	\$ 2,500	\$ 5,000
0001-0000-6001	Interest Earned	\$ 457,933	\$ 20,000	\$ 80,000
0001-0000-6010	Rents & Leases	\$ 500	\$ 500	\$ 500
0001-0000-6011	Cellular 2000 Lease	\$ 42,247	\$ 41,600	\$ 44,810
0001-0000-6013	KVRQ-F Tower Lease	\$ 13,230	\$ 12,600	\$ 13,800
0001-0000-6016	Metro PCS Lease	\$ 44,881	\$ 40,300	\$ 49,164
0001-0000-6026	Cingular @ Water Tower	\$ 21,533	\$ 21,533	\$ 23,139
0001-0000-6053	Ad Display Lease BK Industries	\$ -	\$ -	\$ 1,500
0001-0000-6062	Penalties	\$ 39,238	\$ 35,000	\$ 35,000
0001-0000-6091	Other Revenue	\$ 10,931	\$ 3,000	\$ 7,000
0001-0000-6093	Unrealized Loss/Gain on Investments	\$ 134,664	\$ -	
0001-0000-8005	Trn Fr Water Enterprise	\$ 152,375	\$ 152,375	\$ 152,375

# City of Atwater

## Fiscal Year 2025-26 Budget

### General Fund Revenues (cont.)

Account Number	Description	FY 2023-24 Unaudited	FY 2024-25 Amended Budget as of 3/24/25	FY 2025-26 BUDGET
0001-0000-8014	Trn Fr General Fund Capital		\$ -	
0001-0000-8029	Trn Fr Low to Mod Income	\$ 50,000	\$ 50,000	
0001-1000-6065	Veteran's Brick Project	\$ 1,000	\$ 1,500	
0001-1000-6080	Donations & Contributions	\$ -	\$ -	
0001-1010-6091	Other Revenue	\$ 385	\$ -	
0001-2020-2010	Animal License	\$ 672	\$ 500	\$ 700
0001-2020-2022	Bicycle License	\$ -	\$ -	
0001-2020-2082	Other Licenses And Permits	\$ 7,509	\$ 7,000	\$ 7,000
0001-2020-3021	Post Reimbursements	\$ 3,878	\$ 3,000	\$ 3,000
0001-2020-3023	MUHSD/AESD Reimbursement	\$ 150,302	\$ 160,000	\$ 142,565
0001-2020-3025	State Cops Funding	\$ 175,550	\$ 155,000	\$ 175,000
0001-2020-4025	Live Scan	\$ 3,004	\$ 4,000	\$ 3,000
0001-2020-4030	Vehicle Release Fees	\$ 30,275	\$ 30,000	\$ 35,000
0001-2020-4031	Animal Control Services	\$ 1,612	\$ 2,500	\$ 2,000
0001-2020-4032	Police Special Services	\$ 30,842	\$ 28,000	\$ 30,000
0001-2020-4034	Police Cost Recovery	\$ 7,236	\$ 10,000	\$ 10,000
0001-2020-4039	Unclaimed Property	\$ -	\$ -	
0001-2020-5025	Vehicle Code Fines	\$ 151	\$ 250	\$ 300
0001-2020-5026	Other Fines	\$ 18,191	\$ 20,000	\$ 13,000
0001-2020-5027	Parking Fines	\$ 82,269	\$ 35,000	\$ 35,000
0001-2020-6062	Penalties	\$ 34,900	\$ 80,000	\$ 30,000
0001-2030-2060	Fireworks Permits	\$ 4,052	\$ 3,400	\$ 4,000
0001-2030-3013	Fire District In-lieu Fee	\$ 322,892	\$ 300,000	\$ 325,000
0001-2030-3027	Office of Traffic Safety Grant	\$ -	\$ -	
0001-2030-3134	State Fire Reimbursement	\$ 3,201	\$ 50,000	\$ 20,000
0001-2030-3152	FEMA Fire Grant	\$ -	\$ -	
0001-2030-4010	Fire Inspection Fees	\$ 47,720	\$ 40,000	\$ 40,000
0001-2030-4013	Fire Plan Reviews	\$ 4,911	\$ 3,000	\$ 3,000
0001-2030-4035	Weed Abatement	\$ 1,916	\$ 1,500	\$ 1,500
0001-2030-4038	Fire Dept Response Fee	\$ 13,536	\$ 12,000	\$ 12,000
0001-2030-6091	Other Revenue	\$ 11,330	\$ 8,000	\$ 4,000
0001-4000-1076	Annexation Fees	\$ 289	\$ 4,000	\$ 2,500
0001-4000-2101	Well Permits	\$ 1,486	\$ 900	\$ 3,000
0001-4000-2250	Building Permits	\$ 320,617	\$ 300,000	\$ 325,000
0001-4000-3170	Grant Revenue	\$ -	\$ 40,000	\$ 40,000
	California Energy Commission for Automated Permit Processing (CalAPP)			
0001-4000-4000	Commercial CUP-Gen Plan Update	\$ 478	\$ 3,000	\$ 1,984
0001-4000-4001	Planning Fees	\$ 75,084	\$ 50,000	\$ 40,000
0001-4000-4002	Engineering Admin Fees	\$ -	\$ 5,000	\$ 5,000
0001-4000-4003	Plan Check Fees-Building	\$ 72,556	\$ 93,000	\$ 65,000
0001-4000-4006	CUP Monitoring Fee	\$ -	\$ 1,000	

**City of Atwater**  
Fiscal Year 2025-26 Budget

**General Fund Revenues (cont.)**

Account Number	Description	FY 2023-24 Unaudited	FY 2024-25 Amended Budget as of 3/24/25	FY 2025-26 BUDGET
0001-4000-4009	Engineering Inspection Fees	\$ 51,118	\$ 60,000	\$ 70,000
0001-4000-4012	Misc Building Inspection Fees	\$ 2,340	\$ 2,500	\$ 3,000
0001-4000-4014	Reimbursable Fees	\$ -	\$ 100	\$ 100
0001-4000-4015	Reimbursable Plan Check	\$ 7,809	\$ 25,000	\$ 40,000
0001-4000-4019	Business License Fees	\$ 7,890	\$ 8,000	\$ 11,000
0001-4000-4023	Sale Of Stndrd Specs&Drwngs	\$ 97	\$ 200	\$ 200
0001-4000-4199	Electronic Pmt Processing Fees	\$ -	\$ -	
0001-4003-4014	Reimbursable Fees	\$ 7,705	\$ 10,000	\$ 100
0001-4003-4017	Cannabis Fees	\$ 377,705	\$ 75,000	\$ 75,000
0001-4003-1071	Cannabis Tax	\$ 216,005	\$ 361,200	\$ 351,000
0001-6060-4066	Contracted Recreation Fees	\$ -		
0001-6060-4069	Youth & Adult Sponsorships		\$ 500	\$ 1,000
0001-6060-4102	Men's Summer Softball	\$ 11,000	\$ 9,900	\$ 9,900
0001-6060-4103	Coed Fall Softball	\$ 3,300	\$ 6,600	\$ 5,500
0001-6060-4104	Coed Summer Softball	\$ 8,250	\$ 6,600	\$ 6,600
0001-6060-4105	Coed Volleyball	\$ 19,019	\$ 11,000	\$ 18,000
0001-6060-4108	Youth Flag Football	\$ 9,440	\$ 9,440	\$ 9,500
0001-6060-4109	Youth Volleyball	\$ 10,765	\$ 10,765	\$ 12,000
0001-6060-4110	Youth Indoor Soccer	\$ 2,215	\$ 4,500	\$ 3,500
0001-6060-4111	Men's Fall Softball	\$ 6,050	\$ 9,900	\$ 8,800
0001-6060-4115	Tennis Key	\$ 2,270	\$ 2,050	\$ 2,300
0001-6060-4117	Youth Basketball	\$ 23,975	\$ 25,000	\$ 25,000
0001-6060-4120	Field Rentals	\$ 2,415	\$ 1,500	\$ 1,000
0001-6060-4121	Summer Youth Camps	\$ 9,180	\$ 10,000	
0001-6060-4122	Various Classes	\$ 8,147	\$ 6,370	\$ 8,000
	Summer Youth Classes			
0001-6060-4124	Men's Volleyball			\$ 2,550
0001-6060-4125	Women's Volleyball			\$ 2,550
0001-6060-4126	Aerobics	\$ -	\$ 5,040	\$ 7,000
0001-6060-4199	Electronic Pmt Processing Fees	\$ 4,700	\$ 4,800	\$ 5,000
0001-6060-6014	Community Center Rental	\$ 44,830	\$ 30,000	\$ 40,000
0001-6061-6015	Castle Park Rental	\$ 7,025	\$ 3,000	
0001-6061-6080	Donations & Contributions	\$ 10,000	\$ -	
0001-6062-2094	Miss Atwater	\$ 1,275	\$ -	
0001-6062-2097	Christmas Parade	\$ 74	\$ -	
0001-6062-2098	Christmas Toy Drive	\$ 40	\$ -	
0001-6062-4122	Various Classes	\$ 720	\$ -	
0001-6062-6020	Castle Youth Center Rental	\$ 355	\$ 2,500	
0001-6062-6091	Donations Events	\$ 720	\$ -	\$ 1,000
0001-6064-6010	Rents & Leases - Bloss Mansion	\$ 285	\$ 1,500	200
0001-6066-6010	Rents & Leases - Bloss Library Museum	\$ -	\$ -	\$ 10
	<b>Total Revenues</b>	<b>\$ 20,465,547</b>	<b>\$ 19,564,083</b>	<b>\$20,649,606</b>

# General Fund Expenditures

# City of Atwater

## Fiscal Year 2025-26 Budget

### **MAYOR AND CITY COUNCIL**

#### **Overview**

The City Council is the policy-making body for the City of Atwater. Through duly convened regular, adjourned, and special meetings, the City Council adopts ordinances and resolutions setting forth statutory and regulatory policies of the City. The City Council is elected to overlapping four-year terms. The City Council also serves as the governing board for the Successor Agency to the Atwater Redevelopment Agency, the Board of Directors of the Atwater Fire Protection District, the Board of Directors of the Atwater Public Financing Authority, the Board of Directors of the Atwater Housing Authority, and the Board of Directors of the Atwater Public Improvement Corporation. The City Council appoints the City Manager, City Attorney and all advisory commissions (currently only the Planning Commission).

City Council goals are carried out by City staff under the direction of the City Manager. The City Manager is the link between City Council policy development and policy implementation and City operations. The City Council provides information to the citizens. The City Council meetings are presented live via the City's website, Facebook, and YouTube and supported streaming devices to keep the community informed as to the activities and projects throughout the city. Through the City Council Member community involvement, the Council encourages proactive participation of the citizens in City government. The City Council has an Audit and Finance standing Committee Citizens Oversight Committee for the Public Safety Transactions and Use Tax (Measure B), and a General Plan Technical Advisory Committee.

The City Council's ultimate goal as a policy board is to provide leadership, transparency and vision for the residents of Atwater. The City's mission is to provide innovative, sustained high quality public service to the community by encouraging each employee to work up to their maximum capacity.

The City Council's primary mission is to serve the community by providing professional leadership while enhancing the welfare of the City and responding to the needs of Atwater's residents and businesses. The City Council is sensitive and accessible to all members of the community, and by example, sets a positive tone for handling community issues professionally and delivering excellent City services.

City of Atwater  
Fiscal Year 2025-26 Budget

**MAYOR AND CITY COUNCIL**

Account Number	Description	FY 2023-24 Unaudited	FY 2024-25 Amended Budget as of 3/24/25	FY 2025-26 BUDGET	FY 2025-26 Details
0001-1000-2020	Office Supplies	\$ -			
0001-1000-2021	Special Departmental Expense	\$ 4,096	\$ 3,000	2,200	
	Meeting Supplies (batteries, etc.)				
	Plaques, Certificates, Frames, etc.				
	Veteran's Park Brick Project				
	Other Miscellaneous Departmental Expense				\$ 2,200
0001-1000-3036	Memberships & Subscriptions	\$ 314	\$ 400	48,500	
	LAFCO				\$ 10,000
	League of CA Cities				\$ 15,500
	MCAG				\$ 23,000
0001-1000-3037	Travel/Conferences/Meetings	\$ 15,720	\$ 22,300	20,500	
	League of CA Cities				\$ 12,000
	MCAG One Voice				\$ 6,000
	ICSC Conference				
	City County Dinners				\$ 500
	Other Training, Travel and Reimbursements				\$ 2,000
	<b>Total Expenditures</b>	<b>\$ 20,130</b>	<b>\$ 25,700</b>	<b>\$ 71,200</b>	

# City of Atwater

## Fiscal Year 2025-26 Budget

### **CITY ADMINISTRATION / CITY CLERK**

#### **Overview**

##### Administration:

The City Manager is the administrative head of the municipal government of the City of Atwater. The duties and responsibilities of the City Manager are outlined within the City's Municipal Code. The City Manager is the administrative link between the policies set by the City Council and the action necessary to execute those policies. The City Manager is responsible for providing administrative direction for all City departments in accordance with the policies established by the City Council.

The City Manager provides direction regarding implementation of City Council policies, projects, programs, and priorities. The primary focus is to provide leadership, quality and transparent government, and to facilitate efficient and cost-effective delivery of services.

It is the City Manager's duty to enforce all laws and ordinances of the City. The City Manager has personnel authority over all City employees and is responsible to oversee all organization of City departments, offices and positions and reorganization of any department, division, or unit. It is the City Manager's responsibility to manage and coordinate the development of the City's budget and the City's long-term capital improvement plans and financing strategies for City Council oversight.

It is the City Manager's responsibility to keep the City Council informed and updated on the financial conditions, program implementation and potential needs of the City. It is a role of the City Manager to develop and recommend programs to ensure the economic development and financial stability of the City.

##### City Clerk:

Atwater has an elected City Clerk and utilizes deputized City staff under the direction of the City Manager to handle the day-to-day City Clerk operations, including official recordkeeping, and providing notary and information services to the public, City Council and staff in a professional manner, with impartiality, courtesy, and tact.

The City Clerk's Office records the proceedings of the City Council, Successor Agency to the Atwater Redevelopment Agency, Fire Protection District, Public Improvement Corporation, Housing Authority, and Public Financing Authority meetings; prepares and distributes agendas and minutes for these meetings; prepares and processes ordinances and resolutions. The City Clerk Department provides overall keeping of historical, legal, and official records of the City Council and all City departments. Other duties include retention of legal documents, and administration of the State Political Reform Act and the City of Atwater's Conflict of Interest Code, administers oath of office, processes claims, serves as financial disclosure officer and as the California Public Records coordinator, maintains compliance with State laws regarding the Brown Act, annexations, legal

# City of Atwater

## Fiscal Year 2025-26 Budget

### CITY ADMINISTRATION / CITY CLERK (cont.)

notices, elections, and Fair Political Practices Commission filings; updates Municipal Code and receives and opens bids. The City Clerk also coordinates the consolidation of the General Municipal Election.

Account Number	Description	FY 2023-24 Unaudited	FY 2024-25 Amended Budget as of 3/24/25	FY 2025-26 BUDGET	FY 2025-26 Details
0001-1010-1001	Salaries & Wages, Regular	\$ 313,271	\$ 378,612	\$ 337,505	
	City Manager				\$ 209,418
	Assistant City Clerk/Records Coordinator				\$ 75,786
	Executive Assistant				\$ 52,301
0001-1010-1002	Salaries & Wages, Parttime	\$ 3,336	\$ 3,336	\$ 3,336	
	City Clerk				
0001-1010-1003	Leave Accrual Buy-Out	\$ 72,176	\$ 37,089	\$ 37,089	
0001-1010-1004	Overtime	\$ -	\$ 1,000	\$ 1,000	
0001-1010-1008	In-Lieu Of Insurance Benefit	\$ 11,790	\$ 14,400	\$ 7,200	
0001-1010-1012	Fica/Medicare	\$ 25,795	\$ 27,832	\$ 24,137	
0001-1010-1013	Retirement	\$ 152,936	\$ 135,109	\$ 123,608	
0001-1010-1014	Health Insurance	\$ 16,354	\$ 58,886	\$ 26,834	
0001-1010-1015	Worker's Compensation	\$ 26,340	\$ 32,185	\$ 28,494	
0001-1010-2021	Special Departmental Expense	\$ 4,691	\$ 7,500	\$ 6,700	
	Employee Appreciation Event				\$ 4,000
	City County Dinner				\$ 200
	Misc meetings & refreshments				\$ 2,500
0001-1010-3028	Election Costs	\$ -	\$ 27,958		
0001-1010-3030	Professional Services	\$ 2,914	\$ 4,950	\$ 6,500	
	Certified Records Destruction				\$ 2,750
	Municipal Code website maint				\$ 3,750
0001-1010-3031	Communications	\$ 2,455	\$ 1,850	\$ 1,850	
0001-1010-3033	Printing & Advertising				
0001-1010-3034	Rents & Leases	\$ 4,236	\$ 4,446	\$ 5,000	
	Copier Lease				
0001-1010-3035	Operations & Maintenance	\$ 802	\$ 1,500	\$ 1,500	
	Copier Usage Fees				
0001-1010-3036	Memberships & Subscriptions	\$ 625	\$ 1,355	\$ 1,400	
	AAME				\$ 600
	City Clerk Association of California				\$ 250
	ICSC				\$ 175
	Intl Institute of Municipal Clerks				\$ 375
0001-1010-3037	Travel/Conferences/Meetings	\$ 6,431	\$ 13,600	\$ 16,700	
	AAME				\$ 2,000
	ICSC				\$ 3,000
	League of CA Cities				\$ 5,200
	MCAG One Voice				\$ 5,000
	MCI				\$ 1,500
0001-1010-3038	Training	\$ 2,050	\$ 3,000	\$ 1,500	
	MCI				
0001-1010-3099	Miscellaneous	\$ 1,115	\$ -		
0001-1010-4088	Risk Management Charges	\$ 58,253	\$ 83,328	\$ 68,462	
0001-1010-6021	Machinery & Equipment	\$ 70,915	\$ -		
	<b>Total Expenditures</b>	<b>\$ 776,485</b>	<b>\$ 837,936</b>	<b>\$ 698,815</b>	

# City of Atwater

## Fiscal Year 2025-26 Budget

### **FINANCE**

#### **Overview**

The Finance Department ensures prudent financial management of the City's resources. The Finance Department provides financial management by developing, implementing, and maintaining the City's financial systems. These responsibilities range from the daily administration of City fiscal resources to long range financial planning. The Finance Department is responsible for:

- General accounting
- Accounts payable and receivable management
- Utility billing administration
- Business license payments
- Financial analysis
- Long-range financial planning
- Budget preparation and monitoring

The Finance Department ensures that all financial transactions are accurately recorded by Generally Accepted Accounting Principles (GAAP) and maintain a high level of internal control. We prepare and submit financial related reports and provide timely review and analysis of potential problems and issues. We communicate with all departments and respond to questions and inquiries regarding financial reporting and budgeting.

#### **Objectives**

- Our emphasis is on teamwork, collaboration, integrity and professionalism.
- We provide information that is timely, prompt and accurate.
- Promote an environment that encourages productive and innovative solutions that benefit the Community.
- Provide an environment that emphasizes open communications and full disclosure.

Our focus is on delivering effective and efficient services that stress continuous improvement and result in excellence in customer service.

# City of Atwater

## Fiscal Year 2025-26 Budget

### FINANCE

Account Number	Description	FY 2023-24 Unaudited	FY 2024-25 Amended Budget as of 3/24/25	FY 2025-26 BUDGET	FY 2025-26 Details
0001-1015-1001	Salaries & Wages, Regular	\$ 477,638	\$ 613,514	\$ 669,857	
	Finance Director				\$ 149,957
	Finance Operations Manager				\$ 101,083
	Accountant II				\$ 76,601
	Accountant I				\$ 56,467
	Accounting Technician				\$ 59,218
	Accounting Technician				\$ 52,624
	Account Clerk I/II				\$ 48,680
	Account Clerk I/II				\$ 45,219
	Account Clerk I				\$ 40,365
	Account Clerk I				\$ 39,643
0001-1015-1002	Salaries & Wages, Parttime	\$ 62,059	\$ 67,600	\$ 33,800	
	Parttime Wages (retired annuitant)				
0001-1015-1003	Leave Accrual Buy-Out	\$ 8,960	\$ 15,024	\$ 15,024	
0001-1015-1004	Overtime	\$ 515	\$ 1,800	\$ 1,800	
0001-1015-1008	In-Lieu Of Insurance Benefit	\$ 7,500	\$ 14,400	\$ 14,400	
0001-1015-1012	Fica/Medicare	\$ 41,509	\$ 54,092	\$ 56,218	
0001-1015-1013	Retirement	\$ 233,308	\$ 212,408	\$ 234,402	
0001-1015-1014	Health Insurance	\$ 58,780	\$ 93,906	\$ 119,133	
0001-1015-1015	Worker's Compensation	\$ 44,651	\$ 52,359	\$ 54,229	
0001-1015-1024	Additional Duty	\$ 4,344	\$ 1,922		
0001-1015-2020	Office Supplies	\$ -	\$ 750	\$ 900	
0001-1015-2021	Special Departmental Expense	\$ 419	\$ 750	\$ 900	
0001-1015-3030	Professional Services	\$ 72,747	\$ 175,000	\$ 150,000	
	Financial Statements Audit, GASB's & SCO reports				
	Property/Sales Tax and Other Consulting and Reporting				
0001-1015-3031	Communications	\$ 1,430	\$ 1,500	\$ 1,600	
	Cell Phone				
0001-1015-3034	Rents & Leases	\$ 4,859	\$ 5,200	\$ 5,300	
	Copier Leases				
0001-1015-3035	Operations & Maintenance	\$ 1,135	\$ 1,200	\$ 1,300	
	Copier Usage Fees				
0001-1015-3036	Memberships & Subscriptions	\$ 660	\$ 800	\$ 1,100	
	CSMFO/GFOA/CMTA/CMRTA				
0001-1015-3037	Travel/Conferences/Meetings	\$ 5,961	\$ 10,000	\$ 12,000	
	CSMFO/CMTA/League of CA Cities Conference & Chapter Meetings				
	Springbrook Activate Conference				
0001-1015-3038	Training	\$ 3,207	\$ 2,000	\$ 2,000	
	CSMFO/GFOA Training				
	Miscellaneous Department Training				
0001-1015-4088	Risk Management Charges	\$ 94,224	\$ 130,819	\$ 139,301	
	<b>Total Expenditures</b>	<b>\$ 1,123,906</b>	<b>\$ 1,455,044</b>	<b>\$ 1,513,264</b>	

# City of Atwater

## Fiscal Year 2025-26 Budget

### **HUMAN RESOURCES**

#### **Overview**

##### Human Resources:

The goal of Human Resources is to successfully operate, maintain, and continually improve the City's personnel program to deliver the highest quality work product to those the department serves. The Human Resources Department employs industry recognized best practices to attain a high level of operational performance and prioritizes flexibility and responsiveness to adapt to the increasing complexity of the industry landscape. Core Human Resources services include recruitment, retainment of qualified employees in a diverse workforce, and employee onboarding and orientation services; is responsible for; administration of employee benefits, including post-retirement benefits; payroll administration and required reporting; regulatory compliance with employment labor laws and training; policy and procedures development and administration; job classification, compensation and labor market research; organizational and employee professional development; risk management and health and safety programs; administering claims; employee relations, including coordinating and managing labor negotiations with all labor groups; employee assistance programs; management and security of personnel records; administration of employee performance evaluation programs; and assisting other City departments in employment-related activities and workflows.

City of Atwater  
Fiscal Year 2025-26 Budget

**HUMAN RESOURCES**

Account Number	Description	FY 2023-24 Unaudited	FY 2024-25 Amended Budget as of 3/24/25	FY 2025-26 BUDGET	FY 2025-26 Details
0001-1020-1001	Salaries & Wages, Regular	\$ 329,529	\$ 408,861	\$ 413,066	
	Human Resources Director				\$ 142,201
	Human Resources Analyst				\$ 82,688
	Human Resources Analyst				\$ 78,750
	Human Resources Technician I				\$ 65,829
	Human Resources Assistant				\$ 43,598
0001-1020-1002	Salaries & Wages, Parttime	\$ -	\$ -		
0001-1020-1003	Leave Accrual Buy-Out	\$ 12,763	\$ 24,572	\$ 33,092	
0001-1020-1004	Overtime	\$ 153	\$ 3,000	\$ 1,000	
0001-1020-1008	In-Lieu Of Insurance Benefit	\$ 14,310	\$ 14,400	\$ 14,400	
0001-1020-1012	Fica/Medicare	\$ 27,014	\$ 34,489	\$ 35,309	
0001-1020-1013	Retirement	\$ 160,845	\$ 149,894	\$ 155,702	
0001-1020-1014	Health Insurance	\$ 16,901	\$ 44,982	\$ 47,181	
0001-1020-1015	Worker's Compensation	\$ 29,113	\$ 33,400	\$ 34,060	
0001-1020-1024	Additional Duty		\$ -		
0001-1020-2020	Office Supplies		\$ -		
0001-1020-2021	Special Departmental Expense		\$ -		
0001-1020-3030	Professional Services		\$ -		
0001-1020-3031	Communications	\$ 1,462	\$ 1,000	\$ 3,000	
0001-1020-3034	Rents & Leases	\$ 937	\$ 1,000	\$ 1,200	
	Copier Leases (2)				
0001-1020-3035	Operations & Maintenance	\$ 4	\$ 150	\$ 100	
	Copier Usage Fees				
0001-1020-3036	Memberships & Subscriptions	\$ 622	\$ 5,500	\$ 5,000	
	CALPELRA- CA Labor Public Employers Labor Relations Assoc.				
	Liebert Cassidy Whitmore Consortium				
	Other				
0001-1020-3037	Travel/Conferences/Meetings	\$ 6,159	\$ 10,000	\$ 10,000	
	CALPELRA- CA Labor Public Employers Labor Relations Assoc.				
	Liebert Cassidy Whitmore Consortium				
	Other				
0001-1020-3038	Training	\$ 495	\$ 2,000	\$ 2,000	
	Human Resources Training				
0001-1020-4088	Risk Management Charges	\$ 63,706	\$ 86,371	\$ 85,265	
	<b>Total Expenditures</b>	<b>\$ 664,013</b>	<b>\$ 819,619</b>	<b>\$ 840,375</b>	

# City of Atwater

## Fiscal Year 2025-26 Budget

### CITY TREASURER

#### Overview

The City Treasurer is an elected position. This position is responsible for maintaining the treasury, investment program, and banking services of the City. The treasurer sits as a member of the City’s Audit and Finance Committee along with two council members. The Treasurer is the custodian of the City’s Treasurer Report. Objective of the City Treasurer include:

- To provide an investment program that protects City investments.
- Safely and effectively invest surplus funds to minimize risk and maximize yield.
- Accurate and secure banking, cash and investment reporting.

Account Number	Description	FY 2023-24 Unaudited	FY 2024-25 Amended Budget as of 3/24/25	FY 2025-26 BUDGET	FY 2025-26 Details
0001-1025-1002	Salaries & Wages, Parttime	\$ 2,340	\$ 2,340	\$ 2,340	
	Treasurer				\$ 2,340
0001-1025-1012	Fica/Medicare	\$ 179	\$ 180	\$ 181	
0001-1025-1015	Worker's Compensation	\$ 209	\$ 173	\$ 173	
0001-1025-3036	Memberships & Subscriptions	\$ -	\$ 155	\$ 155	
	CA Municipal Treasurers Association				
0001-1025-3037	Travel/Conferences/Meetings	\$ -	\$ 1,000	\$ 300	
	<b>Total Expenditures</b>	<b>\$ 2,728</b>	<b>\$ 3,848</b>	<b>\$ 3,149</b>	

# City of Atwater

## Fiscal Year 2025-26 Budget

### NON-DEPARTMENTAL

#### Overview

The Non-Departmental budget unit contains appropriations which have not been specifically assigned or allocated to the operating functions within departments of the City's budget. These include a portion of the City Attorney's fees, central building maintenance, payments, and other related general purpose budget items.

Account Number	Description	FY 2023-24 Unaudited	FY 2024-25 Amended Budget as of 3/24/25	FY 2025-26 BUDGET
0001-1050-2020	Office Supplies	\$ 28,144	\$ 45,100	\$ 46,000
	Citywide Office Supplies			
	Mail Machines (supplies, postage)			
	Envelopes/Letterhead/Receipts/Forms			
	Payroll Checks & AP Checks			
	W2 and 1099 Forms			
0001-1050-2021	Special Departmental Expense	\$ 24,903	\$ 20,300	\$ 21,000
	Oral Board Expenses			
	Pre-employment activities			
	Mail Machine Software License			
	Other			
0001-1050-3030	Professional Services	\$ 361,965	\$ 367,000	\$ 367,000
	City Attorney Legal Services			
0001-1050-3033	Printing & Advertising	\$ 6,955	\$ 13,000	\$ 14,000
	Legal, Classified Notices, Other			
0001-1050-3034	Rents & Leases	\$ 6,421	\$ 9,463	\$ 11,000
	Copiers			
	Mail Machines			
0001-1050-3035	Operations & Maintenance	\$ 2,002	\$ 1,740	\$ 2,200
	Copier Usage Fees			
0001-1050-3036	Memberships & Subscriptions	\$ 45,389	\$ 51,100	\$ -
0001-1050-3099	Miscellaneous	\$ 11,391	\$ 20,000	\$ 23,000
	Armored Car Service			
0001-1050-3102	Electronic Pmt Processing Exp	\$ 19,597	\$ 18,500	\$ 20,000
	Front Counter Terminals			
0001-1050-4041	Equipment Maint. Charges	\$ 101,446	\$ 101,746	\$ 100,621
0001-1050-4045	Building Maint. Charges	\$ 877,143	\$ 809,860	\$ 771,687
0001-1050-4087	Information Technology Charges	\$ 709,159	\$ 693,601	\$ 728,520
0001-1050-4089	Employee Benefits Charges	\$ 520,893	\$ 584,417	\$ 648,224
0001-1050-5030	Interest-Interfund Loans	\$ -	\$ -	\$ -
0001-1050-6021	Machinery & Equipment	\$ -	\$ -	0
	<b>Total Expenditures</b>	<b>\$ 2,715,408</b>	<b>\$ 2,735,827</b>	<b>\$ 2,753,252</b>

# City of Atwater

## Fiscal Year 2025-26 Budget

### **POLICE DEPARTMENT - ADMINISTRATION**

#### **Overview**

The Police Administration activity provides support for all Police divisions and bureaus and serves as a liaison with both the attorney's offices and the courts. This activity provides records management, evidence security and the upkeep and maintenance of the department's equipment. This unit assures correct, competent, and courteous service to the public. It provides technical and law enforcement information to both the public and the Department. The Administration division insures responsive telecommunications work in the reception and transmission of 911 and radio emergency for law enforcement service calls as well as complaints and inquiries from the public. It is also responsible for the management of the City's vehicle abatement program, addressing animal control issues, pick-up of animals, issuing citations for animal control violations and the transport of animals to the Merced County Animal Shelter.

Goals of the Administration Division of the Police Department include:

- Public Safety Dispatchers, Police Record Clerks, and Community Service Officers will respond to the citizens of the community in a timely and courteous manner.
- Police Record Clerks will continue to perform professional administrative support work using modern office practices and procedures.
- Public Safety Dispatchers will continue to perform responsive telecommunications work in the reception and transmission of 911 telephone and emergency radio service calls, complaints, and inquiries from the public.
- Community Service Officers will assist with inquiries made by phone and in person regarding department information, handle the vehicle abatement program within the City of Atwater, handle animal complaints such as excessive barking dogs or loose animals, issuing citations for animal control violations, the pick-up of animals and the transport of animals to the Merced County Animal Control Shelter.
- Code Enforcement Unit will address municipal code violations, blight and other quality of life issues affecting the residents of Atwater.
- Community outreach through efforts like APD chaplains and Neighborhood Watch.
- Work with stakeholders to find ways to resolve homeless issues in Atwater.

# City of Atwater

## Fiscal Year 2025-26 Budget

### POLICE DEPARTMENT – ADMINISTRATION

Account Number	Description	FY 2023-24 Unaudited	FY 2024-25 Amended Budget as of 3/24/25	FY 2025-26 BUDGET	FY 2025-26 Details
0001-2020-1001	Salaries & Wages, Regular	\$ 1,001,684	\$ 1,050,800	\$ 1,039,056	
	Police Chief				\$ 192,400
	Police Lieutenant				\$ 156,597
	Executive Assistant				\$ 51,310
	Code Enforcement Manager (90% 2020 / 10% Fd 0009)				\$ 82,684
	Code Enforcement Officer				\$ 59,020
	Public Safety Communications Supervisor				\$ 70,537
	Public Safety Dispatcher				\$ 63,297
	Public Safety Dispatcher				\$ 60,283
	Public Safety Dispatcher				\$ 58,913
	Public Safety Dispatcher				\$ 54,679
	Public Safety Dispatcher				\$ 52,075
	Community Services Officer				\$ 53,291
	Police Clerk II				\$ 45,052
	Police Clerk I				\$ 38,918
0001-2020-1002	Salaries & Wages, Parttime	\$ 151			
0001-2020-1003	Leave Accrual Buy-Out	\$ 48,062	\$ 68,079	\$ 57,502	
0001-2020-1004	Overtime	\$ 12,287	\$ 50,000	\$ 50,000	
0001-2020-1005	Holiday Pay	\$ 25,624	\$ 31,632	\$ 36,604	
0001-2020-1007	Special Duty	\$ 747			
0001-2020-1008	In-Lieu Of Insurance Benefit	\$ 15,411	\$ 21,600	\$ 20,880	
0001-2020-1012	Fica/Medicare	\$ 75,541	\$ 88,140	\$ 87,848	
0001-2020-1013	Retirement	\$ 490,835	\$ 480,866	\$ 496,166	
0001-2020-1014	Health Insurance	\$ 194,579	\$ 246,676	\$ 247,407	
0001-2020-1015	Worker's Compensation	\$ 83,028	\$ 90,539	\$ 88,850	
0001-2020-1024	Additional Duty	\$ 652	\$ -		
0001-2020-2020	Office Supplies	\$ 3,058	\$ 3,000	\$ 3,000	
0001-2020-2021	Special Departmental Expense	\$ 49,393	\$ 25,000	\$ 25,000	
	DA and Citizens portal encumbered in FY 22/23				
	Community Services Supplies				
	E ticket equipment				
	Small equipment Purchases				
	Miscellaneous supplies (First Aid/Protective gear etc.)				
	Furniture/Equipment Replacement				
0001-2020-2024	Uniform & Clothing Expense	\$ 8,403	\$ 10,000	\$ 10,000	
0001-2020-3029	Towing Fees	\$ 1,930	\$ 3,000	\$ 3,000	

City of Atwater  
Fiscal Year 2025-26 Budget

**POLICE DEPARTMENT – ADMINISTRATION (cont.)**

Account Number	Description	FY 2023-24 Unaudited	FY 2024-25 Amended Budget as of 3/24/25	FY 2025-26 BUDGET	FY 2025-26 Details
0001-2020-3030	Professional Services	\$ 187,474	\$ 195,000	\$ 195,000	
	Animal Control Services/Sheltering				
	Callyo Investigation Service				
	Lexipol Management Services				
	Net Motion				
	Credit Checks (Backgrounds)				
	Fingerprint Fees				
	Hospital Fees (Injured Prisoners)				
	Evidence Destruction Expenses				
	Evidence Tow Fees				
	Lexis Nexis (Information Company)				
	Social Media Archive				
	Cell Phone Analsys Software				
	Vet Bills				
	Recruitment/Background expenses				
	Internal Affairs Investigations				
	Forensic Services				
	Range Fees				
	Sexual Assault Exams				
	Pace Scheduling Software				
0001-2020-3031	Communications	\$ 60,800	\$ 80,000	\$ 80,000	
	Wireless Fees				
	Radio Repairs and Equipment				
	CLETS				
	AT&T				
0001-2020-3032	Utilities	\$ -	\$ 25,000	\$ 25,000	
0001-2020-3034	Rents & Leases	\$ 121,852	\$ 185,000	\$ 185,000	
	RIMS Software				
	911 Dispatch Center Lease				
	Copier Lease				
0001-2020-3035	Operations & Maintenance	\$ 2,863	\$ 3,500	\$ 3,500	
	Copier Usage Fees				

# City of Atwater

## Fiscal Year 2025-26 Budget

### POLICE DEPARTMENT – ADMINISTRATION (cont.)

Account Number	Description	FY 2023-24 Unaudited	FY 2024-25 Amended Budget as of 3/24/25	FY 2025-26 BUDGET	FY 2025-26 Details
0001-2020-3036	Memberships & Subscriptions	\$ 1,975	\$ 3,000	\$ 3,000	
	California Association of Chief's				
	California Peace Officers Association				
	FBI Law Enforcement Executive Development				
	International Assoc of Chief's				
	Merced County Chief's Assoc				
	California Association of Code Enforcement Officers				
	Central Sierra Chief's Assoc				
	Cal LEA Records				
	Evidence Association				
0001-2020-3037	Travel\Conferences\Meetings	\$ 7,732	\$ 7,500	\$ 7,500	
0001-2020-3038	Training	\$ 22,826	\$ 20,000	\$ 20,000	
	Dispatch				
	Code Enforcement				
	Administrative Personnel				
0001-2020-3099	Miscellaneous		\$ -	\$ -	
0001-2020-3102	Electronic Pmt Processing Exp	\$ 561	\$ 700	\$ 700	
0001-2020-4041	Equipment Maint. Charges	\$ 243,956	\$ 244,408	\$ 244,593	
0001-2020-4088	Risk Management Charges	\$ 195,573	\$ 257,606	\$ 246,833	
0001-2020-6021	Machinery & Equipment	\$ 60,993	\$ 10,000	\$ 10,000	
0001-2020-6031	Improvements Other Than Bldg	\$ -	\$ -	\$ -	
	<b>Total Expenditures</b>	<b>\$ 2,917,990</b>	<b>\$ 3,201,046</b>	<b>\$ 3,186,439</b>	

# City of Atwater

## Fiscal Year 2025-26 Budget

### **POLICE DEPARTMENT – FIELD OPERATIONS**

#### **Overview**

Police Operations creates and maintains security in the community and the department works with the citizens of Atwater to provide the best public safety service possible; to provide twenty-four-hour patrol service for the community respond to all Calls for Service, resolve conflicts, and identify potential problems of a serious nature. Police Operations goals include enforcing state laws and applicable city ordinances in a fair and courteous manner and providing community relations for crime prevention and crime reduction.

#### **Objectives**

- Law enforcement officers will respond to emergency situations within an average of less than 3 minutes.
- Maintain quarterly DUI and safety checkpoints to reduce DUI's along with related accidents.
- A revitalization of the Atwater Police Department's Reserve Police Officer Program with special emphasis on recruitment and training.
- Fill vacancies and continue to organize the Department to best serve the community.
- Continue to look at technology to assist the department in providing service to the community.
- Find funding to expand and improve the aging and undersized Police Facility.
- Continue to work to decrease gang activity within the City.
- Work with Community Partners to find ways to mitigate homeless issues in Atwater.

**City of Atwater**  
**Fiscal Year 2025-26 Budget**

**POLICE – FIELD OPERATIONS**

<b>Account Number</b>	<b>Description</b>	<b>FY 2023-24 Unaudited</b>	<b>FY 2024-25 Amended Budget as of 3/24/25</b>	<b>FY 2025-26 BUDGET</b>	<b>FY 2025-26 Details</b>
0001-2021-1001	Salaries & Wages, Regular	\$ 1,112,788	\$ 1,211,169	1,278,183	
	Police Sergeant (Detective)				\$ 130,932
	Police Officer (Detective)				\$ 91,982
	Police Officer				\$ 90,482
	Police Officer				\$ 96,815
	Police Officer				\$ 96,506
	Police Officer				\$ 94,244
	Police Officer				\$ 90,482
	Police Officer				\$ 86,173
	Police Officer				\$ 87,673
	Police Officer				\$ 88,327
	Police Officer				\$ 86,173
	Police Officer				\$ 78,162
	Police Officer				\$ 82,070
	Police Officer				\$ 78,162
0001-2021-1002	Salaries & Wages, Parttime	\$ -	\$ -		
0001-2021-1003	Leave Accrual Buy-Out	\$ 45,485	\$ 45,588	47,734	
0001-2021-1004	Overtime	\$ 253,685	\$ 200,000	200,000	
0001-2021-1005	Holiday Pay	\$ 79,865	\$ 95,736	100,242	
0001-2021-1006	Stand By Pay	\$ 6,948	\$ 18,200	9,100	
0001-2021-1007	Special Duty	\$ 17,650	\$ 19,660	19,524	
0001-2021-1008	In-Lieu Of Insurance Benefit	\$ 21,000	\$ 21,600	14,400	
0001-2021-1012	Fica/Medicare	\$ 112,679	\$ 120,414	125,290	
0001-2021-1013	Retirement	\$ 647,654	\$ 766,143	859,901	
0001-2021-1014	Health Insurance	\$ 138,925	\$ 188,908	194,328	
0001-2021-1015	Worker's Compensation	\$ 91,181	\$ 119,421	123,174	
0001-2021-1024	Additional Duty	\$ 406	\$ -		
0001-2021-2020	Office Supplies	\$ 2,326	\$ 3,000	3,000	
	Patrol Room Supplies				
0001-2021-2021	Special Departmental Expense	\$ 60,194	\$ 45,000	45,000	
	Broken Equipment Replacement				
	Explorer Post Funding				
	Ammunition				
	Bloodborne Pathogens Protective Equip				
	Crime Scene Supplies				
	Weapons Cleaning Equipment				
	Flares				
	Gun supplies				
	Interview Room Equipment				
	Truleo Service				
0001-2021-2024	Uniform & Clothing Expense	\$ 30,440	\$ 50,000	50,000	
	Uniform Cleaning, Replacement & Repair				
0001-2021-3030	Professional Services	\$ 2,040	\$ 1,000	1,000	
	Other Professional Servies				

City of Atwater  
Fiscal Year 2025-26 Budget

**POLICE – FIELD OPERATIONS (cont.)**

Account Number	Description	FY 2023-24 Unaudited	FY 2024-25 Amended Budget as of 3/24/25	FY 2025-26 BUDGET	FY 2025-26 Details
0001-2021-3031	Communications	\$ 28,836	\$ 26,000	26,000	
	Air Cards & Cell Phones				
	Portable Radio Equipment				
0001-2021-3034	Rents & Leases	\$ 36,800	\$ 110,000	121,427	
	Axon In Car Video				
	Axon Body Camera Program				
0001-2021-3036	Memberships & Subscriptions	\$ -	\$ -	-	
0001-2021-3037	Travel/Conferences/Meetings	\$ 252	\$ 1,000	1,000	
0001-2021-3038	Training	\$ 34,038	\$ 35,000	35,000	
	Continuation of Enhanced Training Prog (PD Strategic Plan Goal)				
0001-2021-3099	Miscellaneous	\$ -	\$ -	-	
0001-2021-4041	Equipment Maint. Charges	\$ -			
0001-2021-4088	Risk Management Charges	\$ 372,309	\$ 538,227	345,316	
0001-2021-6021	Machinery & Equipment	\$ -	\$ -		
0001-2021-6031	Improvements Other Than Bldg				
	<b>Total Expenditures</b>	<b>\$ 3,095,501</b>	<b>\$ 3,616,066</b>	<b>3,599,619</b>	

# City of Atwater

## Fiscal Year 2025-26 Budget

### **FIRE**

#### **Overview**

The Atwater Fire Department is committed to the preservation of life, property, and the environment, and to assist citizens within the community of Atwater with the highest-level emergency medical service/ response and fire protection. The Atwater Fire Department is customer service oriented — “We care and will be there when called upon.” CAL FIRE will provide services to the City and associated Fire District to fulfill the operational policies and direction of the City Council and District Board. The provision of these services will be through a contractual agreement and CAL FIRE will manage that service delivery within the budget and applicable policies approved by the Atwater City Council/Board of Directors and CAL FIRE policies. Budgeted funds are expended directly by the City and Fire District or by CAL FIRE, and CAL FIRE is reimbursed for their actual direct and in direct expenses for those services which are associated with the contract.

The Fire Department Administration will continue to provide the utmost level of life safety protection for the community, recognizing that Public Safety is of the highest importance to the City Council. The Fire Administration will evaluate the efficiency and effectiveness of the Department by comparing response times, training hours and seasonal project achievements. The Atwater Fire Department will continue to train reserve firefighters to assure that each member of the Department maintains a high level of proficiency in serving the community.

#### **Objectives**

- Fire personnel will respond to emergency situations within an average of less than 7 minutes 90% of the time.
- Provide Public Education to local schools addressing fire safety and injury prevention.
- Manage the Prevention Inspection Program.
- Complete semi-annual fire hydrant flow testing and flushing.
- Recruit and maintain an active reserve fire fighter program.
- Reduce fire loss by quick response, direct interior fire attack and salvage operations.
- Provide annual inspection service to businesses

# City of Atwater

## Fiscal Year 2025-26 Budget

### FIRE

Account Number	Description	FY 2023-24 Unaudited	FY 2024-25 Amended Budget as of 3/24/25	FY 2025-26 BUDGET	FY 2025-26 Details
0001-2030-2020	Office Supplies	\$ 920	\$ 1,000	1,000	
	Misc Office Supplies				400
	Printed Supplies				350
	Pencils, Pens, Note Pads				250
0001-2030-2021	Special Departmental Expense	\$ 48,266	\$ 56,500	61,500	
	Tools, Equipment and PPE				13,000
	Medical supplies				7,500
	Sanitary Supplies				4,000
	Prevention Supplies				3,500
	Furniture Replacement				5,000
	Station Supplies and Maintenance				25,000
	SCBA repair & maint.				3,500
0001-2030-2023	Small Tools	\$ -	\$ -	-	
0001-2030-2024	Uniform & Clothing Expense	\$ -	\$ 1,000	1,000	
	Reserve Uniform T-shirts				600
	Reserve Uniform Sweatshirts				400
0001-2030-2025	Fire Marshal Supplies	\$ 1,744	\$ 3,000	3,000	
	Fire Inspection Forms				1,500
	Fire Marshal Office Supplies				1,500
0001-2030-3030	Professional Services	\$ 2,924,980	\$ 2,779,324	3,244,015	
	Merced County Cost-Sharing Agreement: Mechanic				65,000
	CAL FIRE Agreement				3,173,515
	Weed Abatement Services				2,000
	Streamline Fire Inspection Program				3,500
0001-2030-3031	Communications	\$ 8,417	\$ 7,200	8,000	
	Atwater Comms (iPads)				3,500
	Pager/Radio Maintenance and Replacement				3,000
	Batteries				1,500
0001-2030-3032	Utilities	\$ 39,744	\$ 54,500	61,000	
	PG&E and MID				61,000
0001-2030-3034	Rents & Leases	\$ 3,939	\$ 5,000	5,000	
	Station 41 & 42 Copier Leases				5,000
0001-2030-3035	Operations & Maintenance	\$ 192	\$ 1,000	1,000	
	Copy Machine Usage				1,000
0001-2030-3038	Training	\$ 421	\$ 2,000	2,000	
	Fire Education Courses				2,000
0001-2030-3039	State Emergency Strike Team	\$ -	\$ -	-	
0001-2030-3063	Reserve Fire Fighter Program	\$ -	\$ -	-	
0001-2030-4041	Equipment Maint. Charges	\$ 227,292	\$ 227,899	226,082	
0001-2030-4088	Risk Management Charges		\$ -	-	
0001-2030-6021	Machinery & Equipment	\$ -	\$ -	634,000	Type I Payoff
0001-2030-6031	Improvements Other Than Bldg	\$ -		125,000	
	<b>Total Expenditures</b>	<b>\$ 3,255,915</b>	<b>\$ 3,138,423</b>	<b>4,372,597</b>	

# City of Atwater

## Fiscal Year 2025-26 Budget

### COMMUNITY DEVELOPMENT

#### Overview

The Community Development Department includes the Engineering, Planning, Building, Economic Development, and Housing Divisions.

The Engineering Division plans, organizes, and performs a variety of professional level engineering and inspection services such as preparing, coordinating, and managing capital improvement projects. Engineering recommends improvements and replacement of public facilities, provides technical support to Public Works and other departments, checks the plans for subdivisions and civil improvements, and inspects the improvements before they are accepted by the City. Engineering plays an important role in the review and approval of improvement plans, final maps, parcel maps and lot line adjustments. It also assists in annual oversight of assessment districts such as the lighting, storm drainage, and landscape maintenance districts.

The Planning Division has four principal responsibilities:

1. Prepare, maintain, and implement the City's General Plan, Specific Plans, Master Plans, and other types of plans as needed.
2. Conduct environmental reviews of public and private projects on the California Environmental Quality Act (CEQA) and National Environmental Policy Act (NEPA).
3. Administer the City's Zoning and Subdivision Ordinances including the review of annexations, land use, development, and subdivision projects for compliance with applicable policies, regulations, and standards.
4. Administer the Regional Housing Needs Assessment (RHNA) and provide periodic updates to the Housing Element.

The Planning Division provides professional planning services and support to the Planning Commission and City of Council. It also provides information on zoning and other development issues to the public.

The Building Division provides plan reviews, issues building permits, and performs field inspections to ensure a safe and healthy environment and compliance with local ordinances and state regulations. This division works with the Fire Department – CAL Fire and the Merced County Environmental Health Department regarding hazardous and unsafe buildings and structures. It also responds to complaints about substandard and dangerous buildings. This division also reviews requests for business licenses, and in some instances inspects the buildings to determine code compliance.

The Community Development fees are based on the adopted fee schedule and are charged at the time an application is filed with the City. The fee schedule sets forth those applications for which a deposit is required and those for which a flat fee is imposed. Deposits are required for applications that are difficult to estimate actual processing costs. For these projects, the applicant must pay all costs incurred by the City in processing the applications and may result in either additional charges or a refund to the applicant.

# City of Atwater

## Fiscal Year 2025-26 Budget

### COMMUNITY DEVELOPMENT

#### Overview (cont.)

This approach allows the City to ensure appropriate cost recovery for more complex projects while maintaining a simple fee system for routine applications that have easily estimated costs.

The Economic Development and Special Projects Division seeks to assist the city and other departments on key strategic opportunities, including marketing and developing information for the City which helps persuade new investments, and provides for general support in the implementation of grant opportunities.

The Housing Division provides vision and strategic leadership for the City's housing programs and is responsible for identifying affordable housing development opportunities. The division is also responsible for federal grant and contract administration, delivery of housing programs and services, and implementation of the City's guidelines and procedures. The Division continues to manage its Redevelopment Agency (RDA) assets including land and cash available for development, loans for first-time homebuyers, and other affordable development projects.

### COMMUNITY DEVELOPMENT

Account Number	Description	FY 2023-24 Unaudited	FY 2024-25 Amended Budget as of 3/24/25	FY 2025-26 BUDGET	FY 2025-26 Details
0001-4000-1001	Salaries & Wages, Regular	\$ 763,200	\$ 868,551	903,195	
	Community Development Director				\$ 142,441
	Chief Building Official/Fire Code Official				\$ 132,498
	City Engineer				\$ 124,396
	Civil Engineering Assistant				\$ 77,109
	Senior Planner				\$ 89,499
	Planning Technician				\$ 54,896
	Executive Assistant				\$ 52,301
	Project Accountant/Successor Agency Assistant				\$ 73,635
	Administrative Assistant I				\$ 38,159
	Building Permit Technician II				\$ 63,162
	Building Permit Technician I				\$ 55,099
0001-4000-1002	Salaries & Wages, Parttime	\$ -	\$ -	\$ -	
0001-4000-1003	Leave Accrual Buy-Out	\$ 18,381	\$ 35,442	\$ 50,232	
0001-4000-1004	Overtime	\$ 628	\$ 3,000	\$ 3,000	
0001-4000-1008	In-Lieu Of Insurance Benefit	\$ 8,720	\$ 7,200		
0001-4000-1012	Fica/Medicare	\$ 58,045	\$ 66,563	\$ 73,167	
0001-4000-1013	Retirement	\$ 258,563	\$ 314,371	\$ 330,573	
0001-4000-1014	Health Insurance	\$ 86,546	\$ 113,611	\$ 169,263	
0001-4000-1015	Worker's Compensation	\$ 63,635	\$ 67,727	\$ 70,577	
0001-4000-1024	Additional Duty		\$ -	\$ -	

# City of Atwater

## Fiscal Year 2025-26 Budget

### COMMUNITY DEVELOPMENT (cont.)

Account Number	Description	FY 2023-24 Unaudited	FY 2024-25 Amended Budget as of 3/24/25	FY 2025-26 BUDGET	FY 2025-26 Details
0001-4000-2020	Office Supplies	\$ 3,069	\$ 3,200	\$ 2,500	
	Miscellaneous				\$ 1,700
	Business Cards				\$ 500
	FedEx Overnight Postage				\$ 300
0001-4000-2021	Special Departmental Expense	\$ 64,632	\$ 67,000	\$ 38,500	
	Code Books				\$ 2,500
	Software-Cloud Permit				\$ 33,000
	Miscellaneous				\$ 3,000
0001-4000-2023	Small Tools	\$ -	\$ 300	\$ 300	
0001-4000-2024	Uniform & Clothing Expense	\$ 98	\$ 250	\$ 250	
0001-4000-3030	Professional Services	\$ 419,529	\$ 520,000	\$ 435,000	
	Contracted Services Planning/Building				\$ 300,000
	AB1600 Report				10,000
	Civil Engineering & Design Services				100,000
	MuniServices Business License Processing				25,000
0001-4000-3031	Communications	\$ 2,177	\$ 3,000	\$ 3,000	
	Wireless Fees				
0001-4000-3033	Printing & Advertising	\$ 233	\$ 2,500	\$ 2,000	
0001-4000-3034	Rents & Leases	\$ 6,615	\$ 7,000	\$ 7,000	
	Copier Lease				
0001-4000-3035	Operations & Maintenance	\$ 4,438	\$ 6,100	\$ 6,000	
	Copier Usage Fees				
0001-4000-3036	Memberships & Subscriptions	\$ 3,530	\$ 7,915	\$ 1,895	
	CALBO (Building Officials Org)				\$ 350
	ICC (International Code Council)				\$ 295
	YICC (Yosemite Chapter ICC)				\$ 75
	Environmental System Research Institute				
	ICSC				\$ 175
	APA				\$ 1,000
0001-4000-3037	Travel/Conferences/Meetings	\$ 513	\$ 5,000	\$ 5,300	
	CALBO Hotel, Parking and Travel				\$ 4,800
	Engineering, Planning and Admin Misc. Travel				\$ 500
0001-4000-3038	Training	\$ 145	\$ 7,700	\$ 7,750	
	CALBO (Building Officials Org)				\$ 750
	Commissioner/CDD Training				\$ 7,000
0001-4000-3097	Plan Check Fees	\$ 70,419	\$ 101,000	\$ 65,000	
	Contracted Plan Checks				
0001-4000-3100	Inspection Fees	\$ 57,736	\$ 85,000	\$ 65,000	
	Backup Inspectors				
0001-4000-3102	Electronic Pmt Processing Exp	\$ 4,537	\$ 5,000	\$ 5,500	
0001-4000-4088	Risk Management Charges	\$ 134,659	\$ 178,706	\$ 185,912	
0001-4000-6021	Machinery & Equipment	\$ 90,162	\$ -	\$ -	
0001-4000-6031	Improvements Other Than Bldg		\$ -	\$ -	
	<b>Total Expenditures</b>	<b>\$ 2,120,210</b>	<b>\$ 2,476,136</b>	<b>\$ 2,430,914</b>	

City of Atwater  
Fiscal Year 2025-26 Budget

**COMMUNITY DEVELOPMENT –  
CANNABIS**

Account Number	Description	FY 2023-24 Unaudited	FY 2024-25 Amended Budget as of 3/24/25	FY 2025-26 BUDGET	FY 2025-26 Details
0001-4003-2021	Special Departmental Expense	\$ -	\$ 1,000	\$ 500	
	Miscellaneous Supplies				
0001-4003-3030	Professional Services	\$ 19,839	\$ 30,000	\$ 40,000	
	Attorney Legal Services				\$ 15,000
	Monitoring & Compliance Services				\$ 15,000
	Miscellaneous				\$ 10,000
0001-4003-3033	Printing & Advertising	\$ -	\$ -	\$ 250	
0001-4003-3037	Travel/Conferences/Meetings	\$ -	\$ -	\$ 250	
	<b>Total Expenditures</b>	<b>\$ 19,839</b>	<b>\$ 31,000</b>	<b>\$ 41,000</b>	

# City of Atwater

## Fiscal Year 2025-26 Budget

### **RECREATION DEPARTMENT**

#### **Overview**

The mission of the Recreation Department is to enhance the quality of life in Atwater by providing great experiences through recreational programs. Atwater strives to accomplish this by providing exceptional customer service and offering a variety of recreational programs, services, and recreational facilities for the community. The Recreation Department continues to deliver the level of standard our community deserves and has come to expect.

The Recreation Department is responsible for the planning and supervision of all City-sponsored recreation classes, recreational programs, as well as youth and adult sports programs.

Facilities operated, staffed, scheduled, and maintained by the Recreation Department include the Castle Youth Center, as well as City-owned sports fields.

# City of Atwater

## Fiscal Year 2025-26 Budget

### RECREATION

Account Number	Description	FY 2023-24 Unaudited	FY 2024-25 Amended Budget as of 3/24/25	FY 2025-26 BUDGET	FY 2025-26 Details
0001-6060-1001	Salaries & Wages, Regular	\$ 90,216	\$ 116,707	\$ 122,483	
	Recreation Supervisor				\$ 70,166
	Recreation Coordinator				\$ 52,317
0001-6060-1002	Salaries & Wages, Parttime	\$ 83,896	\$ 122,881	\$ 79,200	
	Seasonal Recreation Leaders (5)				
0001-6060-1003	Leave Accrual Buy-Out	\$ 1,106	\$ -	\$ -	
0001-6060-1004	Overtime	\$ 66	\$ 250	\$ 300	
0001-6060-1007	Special Duty		\$ -		
0001-6060-1008	In-Lieu Of Insurance Benefit	\$ 5,310	\$ 7,200	\$ 7,200	
0001-6060-1012	Fica/Medicare	\$ 13,579	\$ 18,898	\$ 16,002	
0001-6060-1013	Retirement	\$ 76,348	\$ 37,802	\$ 40,375	
0001-6060-1014	Health Insurance	\$ 6,256	\$ 9,498	\$ 10,321	
0001-6060-1015	Worker's Compensation	\$ 14,287	\$ 18,302	\$ 15,436	
0001-6060-1024	Additional Duty	\$ -	\$ -	\$ -	
0001-6060-2020	Office Supplies	\$ -	\$ -	\$ -	
0001-6060-2021	Special Departmental Expense	\$ 130	\$ 600	\$ 450	
0001-6060-2023	Small Tools		\$ 200	\$ 100	
0001-6060-2024	Uniform & Clothing Expense	\$ 357	\$ 800	\$ 500	
0001-6060-2041	Swim Lessons/Aquatics		\$ -		
0001-6060-2042	Drop In		\$ -	\$ 500	
0001-6060-2044	Youth Indoor Soccer	\$ 844	\$ 6,380	\$ 2,000	
	Indoor Soccer Balls				
	Participant Shirts				
	Awards				
	Professional Services - Sports Officials				
	Indoor Soccer Equipment				
0001-6060-2045	Youth Basketball	\$ 11,716	\$ 21,920	\$ 18,000	
	Miscellaneous Supplies/Equipment				
	Participant Shirts				
	Awards				
	Professional Services - Sports Officials				
0001-6060-2046	Youth Flag Football	\$ 4,932	\$ 12,980	\$ 5,500	
	Participant Shirts				
	Awards				
	Miscellaneous Supplies				
	Professional Services - Sports Officials				
0001-6060-2047	Youth Volleyball	\$ 3,970	\$ 5,865	\$ 10,000	
	Participant Shirts				
	Awards				
	Professional Services - Sports Officials				
0001-6060-2048	Track Meet	\$ 585	\$ 750	\$ 600	
	Starter's Gun Blanks				
	Awards/Ribbons				
	Track Meet Equipment				

# City of Atwater

## Fiscal Year 2025-26 Budget

### RECREATION (cont.)

Account Number	Description	FY 2023-24 Unaudited	FY 2024-25 Amended Budget as of 3/24/25	FY 2025-26 BUDGET	FY 2025-26 Details
0001-6060-2049	Coed Volleyball	\$ 7,494	\$ 10,000	\$ 14,000	
	Game Volleyballs				
	Equipment - Pole Padding				
	Awards/T-shirt's				
	Professional Services - Sports Officials				
0001-6060-2050	Men's Summer Softball	\$ 4,427	\$ 8,790	\$ 7,000	
	Softballs				
	Miscellaneous Supplies				
	Awards/T-shirts				
	Professional Services - Sports Officials				
0001-6060-2051	Coed Fall Softball	\$ 4,707	\$ 9,290	\$ 5,000	
	11" Softballs				
	12" Incrediballs				
	Awards/T-shirts				
	Professional Services - Sports Officials				
0001-6060-2052	Men's Fall Softball	\$ 7,572	\$ 11,370	\$ 6,000	
	11" Softballs				
	Dolomark Chalk				
	Awards/T-shirts				
	Professional Services - Sports Officials				
0001-6060-2053	Men's Winter Basketball	\$ -	\$ -		
	Game Balls				
	Awards				
	Professional Services - Sports Officials				
0001-6060-2054	Tennis Key	\$ 570	\$ 3,000	\$ 1,500	
	Rekey Tennis Door Lock				
	Copies of Do Not Duplicate Keys				
	Miscellaneous Supplies -Stencil and Paint				
	Replace Wind Screens				
	Lighting				
0001-6060-2055	Men's Volleyball	\$ -	\$ -	\$ 5,000	
0001-6060-2056	Men's Summer Basketball	\$ -	\$ -	\$ -	
	Game Balls				
	Awards				
	Professional Services - Sports Officials				
0001-6060-2058	Misc Youth Programs	\$ -	\$ -	\$ 500	
	Misc Youth Programs				
	Summer Youth Classes				
0001-6060-2059	Women's Volleyball		\$ -	\$ 5,000	
0001-6060-2062	Special Events		\$ -	\$ -	
0001-6060-2063	Coed Summer Softball	\$ 4,353	\$ 9,290	\$ 7,000	
	11" Softballs				
	12" Incrediballs				
	Awards/T-shirts				
	Professional Services - Sports Officials				

**City of Atwater**  
**Fiscal Year 2025-26 Budget**

**RECREATION (cont.)**

Account Number	Description	FY 2023-24 Unaudited	FY 2024-25 Amended Budget as of 3/24/25	FY 2025-26 BUDGET	FY 2025-26 Details
0001-6060-2064	Contracted Recreation Classes		\$ -	\$ -	
0001-6060-2065	Coed Spring Softball		\$ -	\$ -	
0001-6060-2066	Men's Spring Softball		\$ -	\$ -	
0001-6060-2067	Field Rentals		\$ -	\$ 500	
0001-6060-2068	Community Center Expense	\$ 43	\$ 500	\$ 2,000	
0001-6060-2074	Castle Youth Center Expense	\$ -	\$ 500	\$ 500	
0001-6060-2078	Various Recreation Classes	\$ 1,820	\$ 4,576	\$ 5,000	
0001-6060-2080	Vendor Fair		\$ -	\$ -	
0001-6060-2094	Miss Atwater		\$ -	\$ -	
0001-6060-3030	Professional Services	\$ 10,677	\$ 14,597	\$ 15,000	
	Civic Rec				
0001-6060-3031	Communications	\$ 1,352	\$ 1,020	\$ 1,500	
	Cell Phone				
0001-6060-3032	Utilities	\$ 78,632	\$ 86,000	\$ 85,000	
0001-6060-3033	Printing & Advertising		\$ -	\$ 200	
0001-6060-3034	Rents & Leases	\$ 3,355	\$ 3,500	\$ 2,500	
	Copier Lease				
0001-6060-3035	Operations & Maintenance	\$ 1,658	\$ 2,200	\$ 1,000	
	Copier Usage Fees				
0001-6060-3036	Memberships & Subscriptions	\$ 700	\$ 1,020	\$ 900	
	CPRS Memberships				
0001-6060-3037	Travel/Conferences/Meetings	\$ 3,080	\$ 3,800	\$ 4,000	
	CPRS Conferences/Meetings				
0001-6060-3038	Training	\$ -	\$ 1,500	\$ 1,500	
	CPRS Training				
0001-6060-3102	Electronic Pmt Processing Exp	\$ 7,199	\$ 7,400	\$ 8,000	
	Web Payment				
0001-6060-4088	Risk Management Charges	\$ 32,559	\$ 40,128	\$ 33,849	
0001-6060-6021	Machinery & Equipment		\$ -	\$ -	
0001-6060-6027	Buildings		\$ -	\$ -	
0001-6060-6031	Improvements Other Than Bldg		\$ -	\$ -	
	<b>Total Expenditures</b>	<b>\$ 484,922</b>	<b>\$ 604,514</b>	<b>\$ 541,416</b>	

# City of Atwater

## Fiscal Year 2025-26 Budget

### **COMMUNITY EVENTS**

#### **Overview**

Community events functions are spread among other relevant city departments. The City remains committed to supporting programs and events that enrich the quality of life in Atwater, even as staffing responsibilities have transitioned. Community events duties are now shared among various City departments to ensure continuity of services.

The City continues to offer a range of community-focused activities such as kids and adult craft nights, senior social gatherings, Movies in the Park, and the annual Fall Vendor Fair. These programs are now collaboratively supported through interdepartmental efforts, maximizing available resources while maintaining meaningful community engagement.

The City also remains proud of its annual holiday Toy Drive, a joint effort between Police, and Fire departments, which brings holiday cheer to thousands of local children.

Facility reservations and scheduling for locations such as the Atwater Community Center, Veterans Pavilion and Youth Center, Bloss Mansion Grounds, and the Bloss Library Museum are now managed through coordinated support among City departments. Field rentals and community use of these spaces continue without interruption.

Through innovation and cross-department collaboration, the City of Atwater is committed to maintaining vibrant, inclusive events and community programs.

City of Atwater  
Fiscal Year 2025-26 Budget

**COMMUNITY EVENTS**

Account Number	Description	FY 2023-24 Unaudited	FY 2024-25 Amended Budget as of 3/24/25	FY 2025-26 BUDGET
0001-6062-1001	Salaries & Wages, Regular	\$ 29,914	\$ 48,683	
0001-6062-1002	Salaries & Wages, Parttime	\$ 11,855		
	On-call Intermittent Facility Attendants			
0001-6062-1003	Leave Accrual Buy-Out	\$ 130		
0001-6062-1004	Overtime	\$ 12		
0001-6062-1008	In-Lieu Of Insurance Benefit	\$ -	\$ -	
0001-6062-1012	Fica/Medicare	\$ 2,983	\$ 3,724	
0001-6062-1013	Retirement	\$ 2,474	\$ 15,769	
0001-6062-1014	Health Insurance	\$ 6,275	\$ 9,498	
0001-6062-1015	Worker's Compensation	\$ 3,399	\$ 3,607	
0001-6062-2021	Special Departmental Expense	\$ 1,139	\$ 2,000	\$ 1,000
0001-6062-2054	Tennis Key		\$ -	
0001-6062-2057	Easter Egg Hunt	\$ 563	\$ 1,400	\$ 1,400
0001-6062-2062	Special Events	\$ 73	\$ 1,000	\$ 500
0001-6062-2068	Community Center Expense		\$ -	
0001-6062-2074	Castle Youth Center Expense		\$ -	
0001-6062-2078	Various Events & Classes	\$ 4,730	\$ 11,250	\$ 5,500
	Kids Craft Night			
	Adult Craft/Events			
	Senior Social Events			
	Movies in the Park			
	Atwater Night Out			
	Other - Misc Events			
0001-6062-2080	Vendor Fair	\$ -	\$ 1,000	\$ 1,000
0001-6062-2093	4th of July Celebration	\$ -	\$ 500	
0001-6062-2094	Miss Atwater	\$ 1,275	\$ 2,500	
0001-6062-2096	September 11 Remembrance	\$ -	\$ 1,000	\$ 1,150
0001-6062-2097	Christmas Parade	\$ 74	\$ 250	\$ 900
0001-6062-2098	Christmas Toy Drive	\$ 41	\$ 250	\$ 250
0001-6062-3031	Communications	\$ 1,430	\$ -	\$ 1,600
	Cell Phone			
0001-6062-4088	Risk Management Charges	\$ 3,135	\$ 9,838	\$ -
	<b>Total Expenditures</b>	<b>\$ 69,502</b>	<b>\$ 112,269</b>	<b>\$ 13,300</b>

**City of Atwater**  
Fiscal Year 2025-26 Budget

**PUBLIC WORKS – PARKS OPERATIONS**

**Overview**

The Parks Operations Division provides general park and recreational facility maintenance and related operational support services. The mission of the Parks Operations Division is to provide a park and recreational facility environment that is conducive to a healthy, clean, safe, and pleasurable experience that offers visitors opportunities for a secure place to recreate and to improve their physical and mental well-being, resulting in the enhancement of their quality of life.

The Division maintains and operates 17 developed park sites, totaling approximately 80 acres, 12 acres of landscape area adjacent to roadways and neighborhoods, one community center, one youth center, the Bloss Home Museum and grounds, three covered picnic shelters, two tennis courts, three outdoor basketball courts, the Atwater Skate Park, nine athletic fields and eight play equipment structures.

City of Atwater  
Fiscal Year 2025-26 Budget

**PUBLIC WORKS – PARKS OPERATIONS**

Account Number	Description	FY 2023-24 Unaudited	FY 2024-25 Amended Budget as of 3/24/25	FY 2025-26 BUDGET	FY 2025-26 Details
0001-6061-1001	Salaries & Wages, Regular	\$ 165,069	\$ 173,704	\$ 186,948	
	Parks Maintenance Worker I				\$ 49,045
	Parks Maintenance Worker I				\$ 46,709
	Parks Maintenance Worker I				\$ 46,709
	Parks Maintenance Worker I				\$ 44,485
0001-6061-1002	Salaries & Wages, Parttime	\$ 26,437	\$ 33,280	\$ 18,623	
0001-6061-1003	Leave Accrual Buy-Out	\$ 458	\$ -		
0001-6061-1004	Overtime	\$ 15,811	\$ 30,000	\$ 30,000	
0001-6061-1006	Stand By Pay		\$ -		
0001-6061-1007	Special Duty		\$ -		
0001-6061-1008	In-Lieu Of Insurance Benefit	\$ 4,800	\$ 7,200	\$ 4,800	
0001-6061-1012	Fica/Medicare	\$ 15,943	\$ 18,680	\$ 18,388	
0001-6061-1013	Retirement	\$ 76,163	\$ 56,263	\$ 61,624	
0001-6061-1014	Health Insurance	\$ 22,197	\$ 28,493	\$ 30,963	
0001-6061-1015	Worker's Compensation	\$ 15,800	\$ 18,090	\$ 17,738	
0001-6061-1024	Additional Duty	\$ -	\$ -		
0001-6061-2020	Office Supplies	\$ -	\$ 200		
0001-6061-2021	Special Departmental Expense	\$ 72,933	\$ 55,000	\$ 57,750	
	Parts for Irrigation Repairs				\$ 17,850
	Parts to Repair Push Mowers, Edgers & String Trimmers				\$ 15,750
	Flags				\$ 525
	Concrete				\$ 2,625
	Fertilizer for all Parks				\$ 15,750
	Padlocks				\$ 1,050
	Herbicides & Rodent Control				\$ 4,200
0001-6061-2023	Small Tools	\$ 253	\$ 5,000	\$ 5,000	
0001-6061-2024	Uniform & Clothing Expense	\$ 3,322	\$ 6,000	\$ 6,000	
0001-6061-3001	City Administration Fees - Salary Alloc.	\$ 160,584	\$ 161,092	\$ 166,478	
0001-6061-3030	Professional Services	\$ 47,353	\$ 45,000	\$ 47,250	
	Graffiti Removal				\$ 26,250
	Fence & Gate Repairs				\$ 8,400
	Tree Removal				\$ 12,600
	Misc. Electrical Repairs				
0001-6061-3031	Communications	\$ 1,054	\$ 2,500	\$ 2,500	
0001-6061-3034	Rents & Leases	\$ -	\$ 1,500	\$ 1,500	
	Cement Trailer				\$ 1,000
	Portable Fencing				500
0001-6061-3035	Operations & Maintenance		\$ -	\$ -	
0001-6061-3036	Memberships & Subscriptions		\$ -	\$ -	
0001-6061-3038	Training	\$ -	\$ 500	\$ 1,575	
	Safety Training				1,575
0001-6061-3055	Maint. Buildings & Grounds	\$ 13,351	\$ 33,500	\$ 35,175	
	Replace Ballfield Light Bulbs & Ballasts				1,575
	Maint. For Splash Pad				15,750
	Restroom Repair Parts				2,100
	Repair/Replace Park Signs				2,100
	BBQ Repair/Replacement				3,150
	Parts to Repair Benches/Tables				2,100
	Recreational Facilities Repair & Maintenance				8,400
0001-6061-4088	Risk Management Charges	\$ 34,081	\$ 44,264	\$ 42,886	
0001-6061-6021	Machinery & Equipment	\$ 11,597	\$ 53,000	\$ 50,000	
	New Mower				\$ 50,000
0001-6061-6031	Improvements Other Than Bldg	\$ -	\$ -	\$ -	
	<b>Total Expenditures</b>	<b>\$ 687,206</b>	<b>\$ 773,266</b>	<b>\$ 785,198</b>	

# City of Atwater

## Fiscal Year 2025-26 Budget

### **Miscellaneous:**

<b>Account Number</b>	<b>Description</b>	<b>FY 2023-24 Unaudited</b>	<b>FY 2024-25 Amended Budget as of 3/24/25</b>	<b>FY 2025-26 BUDGET</b>	<b>FY 2025-26 Details</b>
0001-9095-9057	Trn To Gas Tax/Street Improv	\$ 481,500	\$ 526,575	\$ 512,728	
0001-9095-9066	Transfer To Local Trans Fund		\$ -		
0001-9095-9069	Transf To Maint District Funds	\$ 85,692	\$ 141,065	\$ 145,000	
	General Benefit Contribution to Maint Districts				
	Maintenance Districts (Shortfall)				
0001-9095-XXXX	Transfer to Fund 5050 Public Safety CFD			\$ 160,821	
0001-9095-9084	Trn To Employee Benefits Fund	\$ 200,000	\$ 100,000	\$ 100,000	
	Reserve for OPEB Obligations				50,000
	Reserve for Pension Obligations				50,000
0001-9095-9086	Transf To Gen Plan Update Fund	\$ -	\$ -		
0001-9095-9089	Trnsf To General Fund Cap	\$ -	\$ -		
0001-9095-9095	Transfer To AVA Fund		\$ -		
0001-9095-9104	Transf to CDBG/STBG Grant Fund		\$ -		
0001-9095-9111	Transf To ISF Equip/BldgReplac	\$ 100,000	\$ 100,000	\$ 100,000	
	<b>Total Expenditures</b>	<b>\$ 867,192</b>	<b>\$ 867,640</b>	<b>\$ 1,018,549</b>	

# Other Funds

## Revenues and Expenditures

# City of Atwater

## Fiscal Year 2025-26 Budget

### **GENERAL FUND CAPITAL PROJECTS**

#### **Overview**

This fund was developed to provide funding for long-term General Fund capital replacement and infrastructure associated with discretionary projects that have no dedicated funding source.

It will also be used for one-time projects that will improve or enhance General Fund operations and consequently reduce or avoid future operating costs. The source of financing for this fund will be revenues from one-time resources or on-going revenues received above the general operating revenues.

#### **Objectives**

- Set-aside funding for long-term capital needs
- Promote funding for Capital infrastructure replacement
- Promote operations that encourage productive and innovative solutions that benefit the Community
- Provide funding for equipment replacement
- Provide funding for innovative projects and studies
- Provide funding for delivering effective and efficient services that stress continuous improvement and result in excellence in customer service.

City of Atwater  
Fiscal Year 2025-26 Budget

**GENERAL FUND CAPITAL PROJECTS**

Account Number	Description	FY 2023-24 Unaudited	FY 2024-25 Amended Budget as of 3/24/25	FY 2025-26 BUDGET
0003-0000-3168	CMAQ Gt-TrafficSignalSynchrztn			
0003-0000-3187	HSIP-Highway Safety Imp Prg Gt			
0003-0000-3188	CMAQ-Phase II Ped Imp Proj			
0003-0000-3193	CMAQ-Mitchell Schools Ped Prj			
0003-0000-3196	CMAQ-Phase 1 Ped Imp Proj DT	\$ 577,702		
0003-0000-3197	CMAQ-Phase 2 Ped Imp Proj DT	\$ 30,446	\$ 2,016,193	\$ 1,079,237
0003-0000-3198	CMAQ-Phase 3 Ped Imp Proj DT	\$ 33,293	\$ 18,665	
0003-0000-3199	CMAQ-Phase 4 Ped Imp Proj DT	\$ 85,005	\$ 74,422	-
0003-0000-3200	CMAQ-City Wide Signal Synch	\$ 87,747	\$ 1,195,857	\$ 1,020,653
0003-0000-XXXX	CMAQ-Electric Street Sweeper			\$ 499,000
0003-0000-6001	Interest Earned	\$ -		
0003-0000-8001	Trn Fr General Fund	\$ -		
	<b>Total Revenues</b>	<b>\$ 814,193</b>	<b>\$ 3,305,137</b>	<b>\$ 2,598,890</b>
0003-1080-L001	Traffic Signal Synchronization			
0003-1080-N001	HSIP-Highway Safety Imp Prg Gt			
0003-1080-P001	Phase II Ped Imp Proj (CMAQ)			
0003-1080-R003	Mitchell Schools Ped Prj-CMAQ			
0003-1080-U004	Phase 1 Ped Imp Proj Downtown	\$ 251,012		
0003-1080-U005	Phase 2 Ped Imp Proj Downtown	\$ 58,929	\$ 2,016,193	\$ 1,079,237
0003-1080-U006	Phase 3 Ped Imp Proj Downtown	\$ 22,373	\$ 18,665	
0003-1080-U007	City Bldg - Civic Center #1			
0003-1080-U008	Police Dept Remodel/Rehab			
0003-1080-V001	City Bldg - Civic Center #2			
0003-1080-V003	Ace Train Platform			
0003-1080-V014	City Hall Barrier Removal			
0003-1080-V015	Phase 4 Ped Imp Proj Downtown	\$ 36,820	\$ 74,422	
0003-1080-X001	Ralston Park Restrooms	\$ -	\$ -	
0003-1080-X002	Veteran's Park Amenity/Parking Expansion	\$ -	\$ -	
	Parking Expansion			
	Park Amenity			
0003-1080-X003	Splash Pad Seated Shading Area	\$ -		
0003-1080-X004	Tennis Court Resurface	\$ -		
0003-1080-X013	City Wide Traffic Signal Synch	\$ 86,670	\$ 1,195,857	\$ 1,020,653
0003-1080-XXXX	Electric Street Sweeper			\$ 499,000
	<b>Total Expenditures</b>	<b>\$ 455,804</b>	<b>\$ 3,305,137</b>	<b>\$ 2,598,890</b>

# City of Atwater

## Fiscal Year 2025-26 Budget

### PUBLIC SAFETY TRANSACTIONS AND USE TAX FUND

#### Overview

The Public Safety Transactions and Use Tax Fund was established to improve the City's ability to monitor and maintain the revenue and expenditure of Public Safety Transactions and Use Tax. Measure B was approved by the voters in November 2022 and provides a 1 percent sales tax surcharge with the revenue generated to be used to enhance public safety services. The Public Safety Transactions and Use Tax becomes effective on July 1, 2023.

#### Objectives

- Continue to develop and execute the Public Safety Transactions and Use Tax Expenditure Plan as required by ordinance. The purpose of the Public Safety Transactions and Use Tax Expenditure Plan is for the administration and expenditure of the tax purposes. The Plan identifies projects necessary to operate, and/or maintain police and fire protection equipment or apparatus, salaries and benefits and other safety protection service expenses as deemed necessary by the City Council for the benefit of the residents of the City. The plan may be amended from time to time by a majority vote of the City Council so long as the funds are utilized for public safety, police, and fire protection services.
- Fill vacancies and continue to organize both public safety department to best serve the community.
- Continue to look at technology to assist the department in providing service to the community.
- Continue the timely replacement of police and fire equipment.
- Find funding to expand and improve the aging and undersized Police Facility.
- Continue to work to decrease gang activity within the City.

#### Revenues:

Account Number	Description	FY 2023-24 Unaudited	FY 2024-25 Amended Budget as of 3/24/25	FY 2025-26 BUDGET
0004-0000-1031	Sales & Use Tax	\$ 5,711,910	\$ 5,114,700	\$ 5,274,315
0004-0000-6001	Interest Earned	\$ 65,934	\$ 1,000	\$ 15,000
	<b>Total Revenues</b>	<b>\$ 5,777,844</b>	<b>\$ 5,115,700</b>	<b>\$ 5,289,315</b>

**City of Atwater**  
**Fiscal Year 2025-26 Budget**

**PUBLIC SAFETY TRANSACTIONS AND USE TAX FUND**

**Expenses:**

<b>Account Number</b>	<b>Description</b>	<b>FY 2023-24 Unaudited</b>	<b>FY 2024-25 Amended Budget as of 3/24/25</b>	<b>FY 2025-26 BUDGET</b>	<b>FY 2025-26 Details</b>
0004-1050-3030	Professional Services	\$ 125,000	\$ 150,000		
0004-1050-4089	Employee Benefits Charges	\$ 29,245	\$ 26,319	\$ 29,798	
0004-2020-1001	Salaries & Wages, Regular	\$ 97,799	\$ 59,101	\$ 116,054	
	Public Safety Dispatcher				\$ 52,075
	Public Safety Records Supervisor				\$ 63,979
0004-2020-1003	Leave Accrual Buy-Out	\$ 1,146	\$ 1,705	\$ 3,348	
0004-2020-1004	Overtime	\$ 8,566		\$ 5,000	
0004-2020-1005	Holiday Pay	\$ 7,759	\$ 4,774	\$ 9,374	
0004-2020-1006	Stand By Pay	\$ -	\$ 5,200	\$ 5,200	
0004-2020-1008	In-Lieu Of Insurance Benefit	\$ 7,200	\$ 7,200		
0004-2020-1012	Fica/Medicare	\$ 9,266	\$ 5,965	\$ 10,632	
0004-2020-1013	Retirement	\$ 8,110	\$ 19,143	\$ 38,255	
0004-2020-1014	Health Insurance	\$ -	\$ -	\$ 10,321	
0004-2020-1015	Worker's Compensation	\$ 8,141	\$ 5,777	\$ 10,255	
0004-2020-4088	Risk Management Charges	-	-	\$ 24,219	
0004-2020-6021	Machinery & Equipment	\$ 60,162	\$ 17,000	\$ 10,000	
0004-2021-1001	Salaries & Wages, Regular	\$ 529,570	\$ 664,912	\$ 690,160	
	Police Sergeant				\$ 130,932
	Police Sergeant				\$ 121,296
	Police Sergeant				\$ 110,662
	Police Officer				\$ 95,006
	Police Officer				\$ 78,162
	Police Officer				\$ 78,162
	Police Officer				\$ 75,940
0004-2021-1002	Salaries & Wages, Parttime	\$ 7,539	\$ 27,456	\$ 49,660	
	P.T. Salaries - Reserves (1)				\$ 7,920
	P.T. Salaries - Community Service Officers (2)				\$ 41,740
0004-2021-1003	Leave Accrual Buy-Out	\$ 7,805	\$ 24,557	\$ 25,446	
0004-2021-1004	Overtime	\$ 135,746	\$ 80,000	\$ 100,000	
0004-2021-1005	Holiday Pay	\$ 35,775	\$ 51,569	\$ 53,437	
0004-2021-1006	Stand By Pay	\$ 875	\$ 5,200	\$ 4,200	
0004-2021-1007	Special Duty	\$ 1,071	\$ 5,835	\$ 4,524	
0004-2021-1008	In-Lieu Of Insurance Benefit	\$ 3,600	\$ -	\$ 7,200	
0004-2021-1012	Fica/Medicare	\$ 52,474	\$ 65,754	\$ 71,499	
0004-2021-1013	Retirement	\$ 398,118	\$ 417,218	\$ 464,893	
0004-2021-1014	Health Insurance	\$ 83,607	\$ 124,931	\$ 102,619	
0004-2021-1015	Worker's Compensation	\$ 42,162	\$ 63,679	\$ 68,975	
0004-2021-1024	Additional Duty	\$ 1,137	\$ -	\$ -	
0004-2021-2024	Uniform & Clothing Expense		\$ 43,000		
0004-2021-3030	Professional Services	\$ 23,200	\$ 40,000	\$ 74,000	
	LPR				
	DA Citizens Portal				
	VIPER Merced County Agreement				\$ 34,000

City of Atwater  
Fiscal Year 2025-26 Budget

**PUBLIC SAFETY TRANSACTIONS AND USE TAX FUND**

**Expenses (cont.):**

Account Number	Description	FY 2023-24 Unaudited	FY 2024-25 Amended Budget as of 3/24/25	FY 2025-26 BUDGET	FY 2025-26 Details
0004-2021-3031	Communications	\$ -	\$ 4,400	\$ 4,400	
	Neighborhood Watch				
	Cell Phones				
0004-2021-3034	Rents & Leases	\$ 132,452	\$ 200,000	\$ 200,000	
	Taser Lease				
	Police Vehicle Lease -				
	Radio Lease				
	Fleet Expansion Lease -				
0004-2021-4088	Risk Management Charges	\$ 1,013	\$ -	\$ 190,863	
0004-2021-6021	Machinery & Equipment	\$ 119,673	\$ 100,000	\$ 60,000	
	Vehicle upfitting				
0004-2030-1002	Salaries & Wages, Parttime	\$ 64	\$ 5,000	\$ 10,000	
	P.T. SALARIES - (4) Reserve Firefighters Special Pay Only				
0004-2030-1012	Fica/Medicare	\$ 5	\$ 765	\$ 765	
0004-2030-1015	Worker's Compensation	\$ 7	\$ 741	\$ 741	
0004-2030-2021	Special Departmental Expense	\$ 23,534	\$ 7,500	\$ 7,500	
0004-2030-3030	Professional Services	\$ 1,609,754	\$ 2,900,000	\$ 2,789,000	
	CAL FIRE Agreement (partial)				\$ 2,789,000
0004-2030-3031	Communications	\$ -	\$ -	\$ -	
0004-2030-3034	Rents & Leases	\$ 87,917	\$ -		
0004-2030-3063	Reserve Fire Fighter Program	\$ 4,626	\$ 7,000	\$ 7,000	
	Training Props and Supplies				
	Annual Recertifications				
0004-2030-4088	Risk Management Charges	\$ 1,013	\$ -	\$ -	
0004-2030-6021	Machinery & Equipment	\$ 544,885	\$ 470,000	\$ 30,000	
	Replace rescue equipment				\$ 30,000
0004-2030-6031	Improvements Other Than Bldg	\$ 2,065	\$ 245,000		
	Fire Station 41 Bay Doors				
	Bathroom/ADA/Stations Improvements				
	Fire Station 41 Gate Repair				
	Exterior Paint				
	<b>Total Expenditures</b>	<b>\$ 4,212,081</b>	<b>\$ 5,856,701</b>	<b>\$ 5,289,338</b>	

**City of Atwater**  
Fiscal Year 2025-26 Budget

**MEASURE V FUND**

**Overview**

Measure V Fund is established to provide funding for local transportation improvements including fixing potholes and maintaining local roads; reducing traffic congestion on highways and local roads; providing seniors, disabled and veterans with mobility options; improving pedestrian and bike travel; shall the Merced County Transportation Authority enact a 1/2 cent sales tax, providing \$15 million dollars annually for transportation projects for 30 years, that cannot be taken by the State, with citizens' oversight, and requiring all money to be spent entirely in Merced County.

**Objectives**

- To provide the best transportation system

**Revenues and Expenses:**

Account Number	Description	FY 2023-24 Unaudited	FY 2024-25 Amended Budget as of 3/24/25	FY 2025-26 BUDGET
0007-0000-1031	Sales & Use Tax	\$ 851,814	\$ 800,000	\$ 800,000
0007-0000-6001	Interest Earned	\$ 132,152	\$ 1,000	\$ 20,000
	<b>Total Revenues</b>	<b>\$ 983,966</b>	<b>\$ 801,000</b>	<b>\$ 820,000</b>
0007-1080-M007	Fruitland Ave Rd Improvements	\$ 4,143	\$ 2,690,000	\$ 1,385,331
0007-1080-P004	Atw Blvd & First St Signal	\$ -	\$ -	\$ -
0007-1080-X013	City Wide Traffic Synch	\$ 11,229	\$ 143,707	\$ 152,236
0007-3033-3030	Professional Services			\$ 100,000
	<b>Total Expenditures</b>	<b>\$ 15,372</b>	<b>\$ 2,833,707</b>	<b>\$ 1,637,567</b>

# City of Atwater

## Fiscal Year 2025-26 Budget

### MEASURE V 20% ALTERNATIVE MODES FUND

#### Overview

At least twenty percent (20%) of the “Local Projects” funds each jurisdiction receives must be used for Alternative Modes projects. Each jurisdiction may use more than this minimum but not less. The goal of this sub-category of projects is to provide safe alternatives to automobile travel, increase use of alternative modes, and improve air quality and the environment. This sub-category may be used for projects and programs that provide alternatives to single-occupant vehicle use, including but not limited to:

- Sidewalks, crosswalks, safe routes to schools, ADA curb ramps, and other pedestrian projects
- Bicycle projects
- Passenger Rail and railroad crossing safety improvements
- Vanpools, carpools or other ridesharing programs or incentives
- Roundabouts or other air quality improvements or other alternative modes

This sub-category may be used for new projects or programs, for safety improvements, or for maintenance or operation of existing projects or programs. Funds can be used for all phases of project development and implementation.

This sub-category may also be used as an incentive or as matching funds for transportation-related components of sustainable communities and developments that help increase alternatives to automobiles.

#### Revenues and Expenses:

Account Number	Description	FY 2023-24 Unaudited	FY 2024-25 Amended Budget as of 3/24/25	FY 2025-26 BUDGET
0008-0000-1031	Sales & Use Tax	\$ 212,953	\$ 195,000	\$ 195,000
0008-0000-6001	Interest Earned	\$ 21,887	\$ 1,000	\$ 1,000
	<b>Total Revenues</b>	<b>\$ 234,840</b>	<b>\$ 196,000</b>	<b>\$ 196,000</b>
0008-1080-N001	HSIP-Highway Safety Imp Prg Gt		\$ -	
0008-1080-P001	Phase II Ped Imp Proj		\$ -	
0008-1080-R002	Active Transportation Plan	\$ -	\$ 120,000	
0008-1080-R003	Mitchell Schools Ped Prj		\$ -	
0008-1080-U004	Phase 1 Ped Imp Proj Downtown	\$ 76,688	\$ -	
0008-1080-U005	Phase 2 Ped Imp Proj Downtown	\$ 7,635	\$ 287,006	\$ 391,796
0008-1080-U006	Phase 3 Ped Imp Proj Downtown	\$ 2,899	\$ 7,101	
0008-1080-V003	Ace Train Platform	\$ -		
0008-1080-V015	Phase 4 Ped Imp Proj Downtown	\$ 4,770	\$ 9,642	
	<b>Total Expenditures</b>	<b>\$ 91,992</b>	<b>\$ 423,749</b>	<b>\$ 391,796</b>

# City of Atwater

## Fiscal Year 2025-26 Budget

### ABANDONED VEHICLE PROGRAM FUND

#### Overview

The California Vehicle Code Sections 9250.7 and 22710 establishes a service authority for the abatement of abandoned vehicles. The Police Department participates in a abandoned vehicle abatement program established and administered by the Merced County Association of Governments (MCAG). The funds dispersed to the City of Atwater by MCAG are restricted and can only be used to support the abatement of abandoned vehicles within the City of Atwater.

Goals of the Abandoned Vehicle Program of the Police Department include:

- Community Service and Code Enforcement Officers will respond to the citizens of the community in a timely and courteous manner.
- Community Service and Code Enforcement Officers will assist with inquires made by phone and in person regarding handling of the vehicle abatement program within the City of Atwater.
- Community Service and Code Enforcement Officers will investigate and act to mitigate the effects of abandoned vehicles on the quality of life for residents in the City of Atwater.

#### Revenues and Expenses:

Account Number	Description	FY 2023-24 Unaudited	FY 2024-25 Amended Budget as of 3/24/25	FY 2025-26 BUDGET	FY 2025-26 Details
0009-2020-3192	Abandoned Vehicle Abatement (AVA)	\$ 24,807	\$ 29,716	\$ 30,938	
0009-0000-6001	Interest Earned	\$ 7	\$ -	\$ 20	
	<b>Total Revenues</b>	<b>\$ 24,814</b>	<b>\$ 29,716</b>	<b>\$ 30,958</b>	
0009-2020-1001	Salaries & Wages, Regular	\$ 14,151	\$ 14,995	15,108	
	Code Enforcement Manager (10% Salaries & Benefits)				\$ 9,187
	Community Services Officer (10% Salaries & Benefits)				\$ 5,921
0009-2020-1003	Leave Accrual Buy-Out	\$ 518	\$ 43	43	
0009-2020-1004	Overtime	\$ 441	\$ -	1,000	
0009-2020-1008	In-Lieu Of Insurance Benefit	\$ 489	\$ -	720	
0009-2020-1012	Fica/Medicare	\$ 1,118	\$ 1,150	1,291	
0009-2020-1013	Retirement	\$ 1,088	\$ 4,857	4,980	
0009-2020-1014	Health Insurance	\$ 2,023	\$ 2,849	2,064	
0009-2020-1015	Worker's Compensation	\$ 1,169	\$ 1,114	1,245	
0009-2020-1024	Additional Duty	\$ 67	\$ -		
0009-2020-2021	Special Departmental Expense	\$ -	\$ -		
0009-2020-3031	Communications	\$ 1,081	\$ 1,000	1,000	
	Cell Phone				
0009-2020-4088	Risk Management Charges	\$ 2,427	\$ 3,334	3,073	
0009-2020-4089	Employee Benefit Charges	\$ 444	\$ 423	423	
	<b>Total Expenditures</b>	<b>\$ 25,016</b>	<b>\$ 29,765</b>	<b>30,948</b>	

**City of Atwater**  
Fiscal Year 2025-26 Budget

**MEASURE V – REGIONAL FUNDS**

**Overview**

Measure V Regional Fund is established to provide funding for regional transportation improvements and is part of the Merced County Transportation Authority’s 1/2 cent sales tax, providing \$15 million dollars annually for transportation projects for 30 years, that cannot be taken by the State, with citizens’ oversight, and requiring all money to be spent entirely in Merced County on approved regional transportation improvements.

**Objectives**

- To provide regional transportation improvements within Merced County.

**Revenues and Expenses:**

<b>Account Number</b>	<b>Description</b>	<b>FY 2023-24 Unaudited</b>	<b>FY 2024-25 Amended Budget as of 3/24/25</b>	<b>FY 2025-26 BUDGET</b>
0010-0000-1031	Sales & Use Tax	\$ -	\$ -	
0010-0000-1068	Bellevue Road Realignment	\$ -	\$ 2,379,834	\$ 2,150,000
0010-0000-1069	Buhach Widening	\$ -	\$ 200,000	\$ 200,000
0010-0000-6001	Interest Earned	\$ -	\$ -	\$ -
	<b>Total Revenues</b>	<b>\$ -</b>	<b>\$ 2,579,834</b>	<b>\$ 2,350,000</b>
0010-1080-L005	Winton Way Road Improvements			
0010-1080-V017	Bellevue Road Realignment	\$ 30,171	\$ 2,150,000	\$ 2,150,000
0010-1080-X016	Buhach Widening		\$ 200,000	\$ 200,000
	<b>Total Expenditures</b>	<b>\$ 30,171</b>	<b>\$ 2,350,000</b>	<b>\$ 2,350,000</b>

# City of Atwater

## Fiscal Year 2025-26 Budget

### **ARPA-AMERICAN RESCUE PLAN ACT FUND**

#### **Overview**

On March 11, 2021, President Biden signed the American Rescue Plan Act (ARPA) of the 2021 Rescue Plan into law. The \$1.9 trillion package was intended to combat the COVID-19 pandemic, including public health and economic impacts. The Rescue Plan provides funding for many different relief programs.

The City of Atwater was awarded \$7,071,141 and received the funds in two equal tranches. The first tranche was received on July 13, 2021 and the second was received in July 2022.

In accordance with the ARPA Final Rule, the City is spending the remaining ARPA funds for obligations associated with Civic Center 2, and a contract with Willdan to support the City in updating user fees and development impact fees.

City of Atwater  
Fiscal Year 2025-26 Budget

**ARPA-AMERICAN RESCUE PLAN ACT FUND**

**Expenses:**

Account Number	Description	FY 2023-24 Unaudited	FY 2024-25 Amended Budget as of 3/24/25	FY 2025-26 BUDGET
1010-0000-3137	ARPA-Coronavirus FscI Recovery		\$ -	\$ -
1010-0000-6001	Interest Earned	\$ 119,953	\$ -	\$ -
	<b>Total Revenues</b>	<b>\$ 119,953</b>	<b>\$ -</b>	<b>\$ -</b>
1010-1050-1009	Premium Pay to Essential Wrkrs	\$ 123,798	\$ -	
1010-1050-3030	Professional Services		\$ 102,625	\$ 81,717
1010-1050-3036	Memberships & Subscriptions-Virtual Meetings		\$ -	
1010-1080-M007	Fruitland Ave Phase 3	\$ -	\$ 900,801	
1010-1080-U007	City Bldg - Civic Center #1	\$ -	\$ -	
1010-1080-U008	Police Dept Remodel/Rehab	\$ 73,527	\$ 33,421	
1010-1080-V001	City Bldg - Civic Center #2	\$ 905,376	\$ 691,095	\$ 83,849
1010-1080-V038	Memorial Ball Park Parkng Lot (Cedar & First)	\$ 67,428	\$ -	
1010-1080-V039	Osborn Park Renovation	\$ -	\$ 38,321	
1010-1080-W002	Palm & Bellevue Street & Sidewalk Improvements	\$ 5,954		
1010-1080-X007	First Street Overlay	\$ 571,642		
1010-1080-X015	Suncrest/Fortuna Overlay Proj	\$ 200,786	\$ -	
1010-1080-X004	Tennis Court Resurfacing		\$ 29,300	
1010-9095-9050	Trn to General Fund		\$ 880,743	
	<b>Total Expenditures</b>	<b>\$ 1,948,511</b>	<b>\$ 2,676,306</b>	<b>\$ 165,566</b>

# City of Atwater

## Fiscal Year 2025-26 Budget

### GAS TAX / STREET IMPROVEMENT FUND

#### Overview

Under the Direction of the Public Works Director, the Public Works Streets Division oversees the operation, maintenance and safety of streets, street signage, public parking lots, medians, sidewalks, maintain traffic control devices, street pavement markers, traffic lane delineation, signing, street lighting and traffic signals. The Streets Division also abates weeds in street and alley rights-of-way and promotes safe work practices and conditions on the City's Streets. Additionally, the Streets Division is responsible for the maintenance and care of the trees that exist within the City's Urban Forestry Plan.

#### Objectives

- Provide maintenance of City's streets, alley ways, sidewalks, and parking lots.
- Provide maintenance and repair of City maintained street lighting.
- Insuring clean and safe city streets.
- Respond and assist in the emergency needs of Police and Fire Services: traffic control, road closures, barricades, etc.
- Respond and assist in the emergency needs of Public Works: flooding, signals, etc.

#### Revenues:

Account Number	Description	FY 2023-24 Unaudited	FY 2024-25 Amended Budget as of 3/24/25	FY 2025-26 BUDGET
1011-0000-3140	Gas Tax 2103	\$ 288,827	\$ 293,870	\$ 297,408
1011-0000-3141	Gas Tax 2105	\$ 192,616	\$ 200,592	\$ 205,264
1011-0000-3142	Gas Tax 2106	\$ 92,786	\$ 94,088	\$ 96,578
1011-0000-3143	Gas Tax 2107	\$ 260,723	\$ 273,698	\$ 279,863
1011-0000-3144	Gas Tax 2107.5	\$ 6,000	\$ 6,000	\$ 6,000
1011-0000-4140	Admin Fees, General Fund - Salary Alloc.	\$ 74,041	\$ 74,041	\$ 80,652
1011-0000-4145	Admin Fees, Maintenance Dist - Salary Alloc.	\$ 16,453	\$ 16,453	\$ 17,923
1011-0000-4024	Traffic Engineering Plan Check	\$ 15,319	\$ 5,000	\$ 5,000
1011-0000-6001	Interest Earned	\$ -	\$ -	\$ -
1011-0000-6091	Other Revenue	\$ 4,853	\$ -	\$ -
1011-0000-8001	Trn Fr General Fund	\$ 481,500	\$ 526,575	\$ 512,728
	<b>Total Revenues</b>	<b>\$ 1,433,118</b>	<b>\$ 1,490,317</b>	<b>\$ 1,501,415</b>

**City of Atwater**  
**Fiscal Year 2025-26 Budget**

**GAS TAX/STREET IMPROVEMENT FUND**

**Expenses:**

<b>Account Number</b>	<b>Description</b>	<b>FY 2023-24 Unaudited</b>	<b>FY 2024-25 Amended Budget as of 3/24/25</b>	<b>FY 2025-26 BUDGET</b>	<b>FY 2025-26 Details</b>
1011-3033-1001	Salaries & Wages, Regular	\$ 241,698	\$ 258,628	273,422	
	Street and Parks Division Supervisor				\$ 86,088
	Streets Maint Worker II				\$ 53,774
	Streets Maint Worker I				\$ 44,484
	Streets Maint Worker I				\$ 46,709
	Streets Maint Worker I				\$ 42,367
1011-3033-1002	Salaries & Wages, Parttime	\$ 10,617	\$ 20,103	18,623	
	Streets Maint Worker I				
1011-3033-1003	Leave Accrual Buy-Out	\$ 3,722	\$ 7,258	8,002	
1011-3033-1004	Overtime	\$ 10,681	\$ 14,000	14,700	
1011-3033-1006	Stand By Pay	\$ 12,454	\$ 14,000	14,000	
1011-3033-1008	In-Lieu Of Insurance Benefit	\$ 2,400	\$ 7,200	-	
1011-3033-1012	Fica/Medicare	\$ 20,372	\$ 24,571	25,149	
1011-3033-1013	Retirement	\$ 111,106	\$ 91,715	98,859	
1011-3033-1014	Health Insurance	\$ 50,533	\$ 56,547	92,298	
1011-3033-1015	Worker's Compensation	\$ 21,018	\$ 23,795	24,259	
1011-3033-2020	Office Supplies	\$ -	\$ -		
1011-3033-2021	Special Departmental Expense	\$ 151,468	\$ 184,900	194,150	
	Concrete				\$ 68,250
	Misc Bolts/Nuts				\$ 1,315
	Weed Spray				\$ 4,200
	Paint and Bead for Roadway Painting				\$ 26,250
	Ant Control/Bait				\$ 525
	Form Materials				\$ 3,150
	Base Rock				\$ 5,250
	Signal Lights/Street Signs				\$ 26,250
	Small Equipment Parts/Supplies				\$ 52,500
	Absorbent for Oil/Gas Spills				\$ 525
	First Aid Supplies				\$ 160
	Barricades/Batteries/Photo Cells/Cones				\$ 3,675
	Speaking Crosswalks for Visually Impaired				\$ 2,100
1011-3033-2023	Small Tools	\$ 16,232	\$ 19,500	19,500	
	Gas Powered Tools				\$ 8,000
	Power Hand Tools				\$ 6,000
	Shovels/Rakes/Brooms				\$ 5,500
1011-3033-2024	Uniform & Clothing Expense	\$ 3,626	\$ 7,000	7,000	
	Safety Gear/Gloves/PPE				
1011-3033-3001	City Administration Fees	\$ 114,255	\$ 131,309	127,342	

City of Atwater  
Fiscal Year 2025-26 Budget

**GAS TAX/STREET IMPROVEMENT FUND (cont.)**

Account Number	Description	FY 2023-24 Unaudited	FY 2024-25 Amended Budget as of 3/24/25	FY 2025-26 BUDGET	FY 2025-26 Details
1011-3033-3030	Professional Services	\$ 118,398	\$ 183,300	162,165	
	Fire Extinguishers				\$ 1,890
	Small Equipment Repairs				\$ 5,250
	Street Tree Removal/Trimming				\$ 42,000
	Signal Light Repairs				\$ 42,000
	Traffic Engineer				\$ 60,000
	Graffiti Removal				\$ 4,200
	DOT Drug Screening/Physicals				\$ 525
	Hazardous Waste Disposal				\$ 1,050
	Tipping Fees				\$ 5,250
1011-3033-3031	Communications	\$ 3,256	\$ 4,000	4,000	
	Cell Phone				
1011-3033-3032	Utilities	\$ 219,503	\$ 225,000	225,000	
1011-3033-3034	Rents & Leases	\$ -	\$ 500	500	
	Trailer/Man Lift Rentals				
1011-3033-3038	Training	\$ 804	\$ 3,100	1,100	
	Drug & Alcohol Awareness				
	Misc Training				
1011-3033-4041	Equipment Maint. Charges	\$ 23,800	\$ 23,800	24,290	
1011-3033-4045	Building Maint. Charges	\$ 32,462	\$ 29,972	28,560	
1011-3033-4088	Risk Management Charges	\$ 48,616	\$ 62,675	66,151	
1011-3033-4089	Employee Benefits Charges	\$ 56,836	\$ 63,092	72,548	
1011-3033-6021	Machinery & Equipment	\$ 52,918	\$ 34,000	-	
	Service Truck				
	<b>Total Expenditures</b>	<b>\$ 1,326,775</b>	<b>\$ 1,489,965</b>	<b>\$ 1,501,617</b>	

City of Atwater  
Fiscal Year 2025-26 Budget

**LOCAL TRANSPORTATION FUND**

**Overview**

Capital project costs associated with traffic safety improvements are funded from the Local Transportation Fund.

**Revenues and Expenses:**

Account Number	Description	FY 2023-24 Unaudited	FY 2024-25 Amended Budget as of 3/24/25	FY 2025-26 BUDGET
1013-0000-3145	Local Transportation	\$ 377,505		
1013-0000-3148	Covid Resp/Relief Supp App Act			
1013-0000-4008	Bridge Widening	\$ 1,277		
1013-0000-6001	Interest Earned	\$ 18,750		\$ 1,000
	<b>Total Revenues</b>	<b>\$ 397,532</b>	<b>\$ -</b>	<b>\$ 1,000</b>
1013-1080-M007	Fruitland Ave Rd Improvements	\$ -	\$ 164,458	\$ 164,458
1013-1080-P004	Atw Blvd & First St Signal	\$ 238,043		
1013-1080-T004	LTF-Laurel Area Sdwk Imp Proj	\$ -		
1013-1080-X014	Olive Avenue Overlay	\$ -	\$ 230,370	\$ 230,370
	<b>Total Expenditures</b>	<b>\$ 238,043</b>	<b>\$ 394,828</b>	<b>\$ 394,828</b>

City of Atwater  
Fiscal Year 2025-26 Budget

**TRAFFIC CIRCULATION FUND**

**Overview**

Capital project costs associated with traffic safety improvements are funded from the Traffic Circulation Fund.

**Revenues and Expenses:**

Account Number	Description	FY 2023-24 Unaudited	FY 2024-25 Amended Budget as of 3/24/25	FY 2025-26 BUDGET
1015-0000-1075	Traffic Circulation Tax	\$ 10,257	\$ -	\$ 4,676
1015-0000-4092	Avenue One Traffic Signal	\$ 371	\$ -	\$ 2,601
1015-0000-4093	Signal @ Commerce/Applegate		\$ -	
1015-0000-4094	Signal @ Bell Dr		\$ -	
1015-0000-4096	Applegate Traffic Signal		\$ -	
1015-0000-6001	Interest Earned	\$ 39,963	\$ -	\$ 1,000
1015-0000-6024	Traffic Signals & Opticons	\$ 829	\$ -	\$ 399
	<b>Total Revenues</b>	<b>\$ 51,420</b>	<b>\$ -</b>	<b>\$ 8,676</b>
1015-1080-L001	Traffic Signal Synchronization		\$ -	
1015-1080-U003	Winton Way & Bellevue Signal		\$ -	
1015-1080-X008	Traffic Signal at Juniper Ave & Bridgewater St.	\$ -	\$ -	\$ 184,000
	<b>Total Expenditures</b>	<b>\$ -</b>	<b>\$ -</b>	<b>\$ 184,000</b>

**City of Atwater**  
Fiscal Year 2025-26 Budget

**RSTP – REGIONAL SURFACE TRANSPORTATION PROGRAM FUND**

**Overview**

The Regional Surface Transportation Program (RSTP) was established by California State Statute utilizing Surface Transportation Block Grant Program (STBGP) funds that are identified in Section 133 of Title 23 of the United States Code. This program promotes flexibility in State and local transportation decisions and provides flexible funding to best address State and local transportation needs.

**Revenues and Expenses:**

Account Number	Description	FY 2023-24 Unaudited	FY 2024-25 Amended Budget as of 3/24/25	FY 2025-26 BUDGET
1017-0000-3147	RSTP Exchange	\$ 437,727	\$ 444,743	
1017-0000-6001	Interest Earned	\$ 69,980	\$ 5,000	\$ 5,000
	<b>Total Revenues</b>	<b>\$ 507,707</b>	<b>\$ 449,743</b>	<b>\$ 5,000</b>
1017-1080-L001	Traffic Signal Synchronization	\$ -	\$ -	
1017-1080-M007	Fruitland Ave. Rd Improvements	\$ -	\$ 2,230,350	\$ 2,230,350
1017-1080-P004	Atwater Blvd. & First St. Signal	\$ 367,100	\$ -	
1017-1080-V003	Ace Train Platform	\$ 30,582	\$ 487,861	
1017-1080-X014	Olive Avenue Overlay		\$ 200,000	\$ 200,000
	<b>Total Expenditures</b>	<b>\$ 397,682</b>	<b>\$ 2,918,211</b>	<b>\$ 2,430,350</b>

**City of Atwater**  
Fiscal Year 2025-26 Budget

**SB 1 - ROAD MAINTENANCE AND REHABILITATION RMRA  
FUND**

**Overview**

Senate Bill (SB) 1, Chapter 5, Statutes of 2017, created the Road Maintenance and Rehabilitation Program (RMRP) to address deferred maintenance on the State Highway System and the local street and road system, and the Road Maintenance and Rehabilitation Account (RMRA) for the deposit of various funds for the program. A percentage of this new RMRA funding will be apportioned by formula to eligible cities and counties pursuant to Streets and Highways Code section 2032(h) for basic road maintenance, rehabilitation, and critical safety projects on the local streets and roads system.

Cities and counties receiving RMRA funds must comply with all relevant federal and state laws, regulations, policies, and procedures. Expenditure authority for RMRA funding is governed by Article XIX of the California Constitution; Revenue and Taxation Code, Division 2, Part 5, Chapter 6, section 11051; and Streets and Highways Code, Chapter 2, Division 3, section 2030 (b). Program requirements include Streets and Highways Code sections 2034, 2036, 2037, and 2038.

**Revenues and Expenses:**

Account Number	Description	FY 2023-24 Unaudited	FY 2024-25 Amended Budget as of 3/24/25	FY 2025-26 BUDGET
1018-0000-3139	SB1	\$ 819,368	\$ 801,841	\$ 860,088
1018-0000-6001	Interest Earned	\$ 60,277	\$ -	\$ 5,000
	<b>Total Revenues</b>	<b>\$ 879,645</b>	<b>\$ 801,841</b>	<b>\$ 865,088</b>
1018-1080-M007	Fruitland Ave Rd Improvements	\$ 138,097	\$ 2,447,653	
1018-1080-P004	Atw Blvd & First St Signal	\$ 275,000	\$ -	
1018-1080-U004	Phase 1 Ped Imp Proj Downtown	\$ 460	\$ -	
1018-1080-V005	Almador Terr&Harbor Dr.Crack/S		\$ -	
1018-1080-V006	Sidewalk Repairs var. location			
1018-1080-V007	Atwater Blvd Strip (former RDA)			
1018-1080-V008	Broadway Traffic Retasking		\$ -	
1018-1080-Y001	Curb, Gutter, and Sidewalk Maintenance, Repair and Replacement		\$ 200,000	\$ 200,000
1018-1080-Y002	Pavement Markings and Signage Maintenance		\$ 160,000	\$ 160,000
1018-1080-Y003	Traffic Signals Maintenance and Repairs		\$ 20,000	\$ 20,000
1018-1080-Y004	Pavement Repairs		\$ 192,583	\$ 192,583
1018-1080-X014	Olive Avenue Overlay		\$ 100,000	\$ 100,000
	<b>Total Expenditures</b>	<b>\$ 413,557</b>	<b>\$ 3,120,236</b>	<b>\$ 672,583</b>

City of Atwater  
Fiscal Year 2025-26 Budget

**PARKS AND RECREATION FACILITIES FUND**

**Overview**

Costs related to City parks and playground improvements are funded from the Parks and Recreation Fund.

**Revenues and Expenses:**

Account Number	Description	FY 2023-24 Unaudited	FY 2024-25 Amended Budget as of 3/24/25	FY 2025-26 BUDGET
1020-0000-1073	Parks & Rec. Facility Tax	\$ 9,920	\$ 8,680	\$ 8,680
1020-0000-1074	Parks Capital Improvemt Tax	\$ 3,968	\$ 3,472	\$ 3,472
1020-0000-1079	Youth Center Facility Tax	\$ 5,168	\$ 4,522	\$ 4,522
1020-0000-3153	Osborn Park Renovation	\$ 128,728	\$ -	\$ -
1020-0000-6001	Interest Earned	\$ 60,447	\$ 1,000	\$ 1,000
	<b>Total Revenues</b>	<b>\$ 208,231</b>	<b>\$ 17,674</b>	<b>\$17,674</b>
1020-1080-V038	Cedar and First Parking Lot	\$ 80,000	\$ -	\$ -
1020-1080-V039	Osborn Park Renovation	\$ 22,000	\$ 600,000	\$ 400,000
1020-1080-X009	Pickleball Court	\$ -	\$ -	\$ -
	<b>Total Expenditures</b>	<b>\$ 102,000</b>	<b>\$ 600,000</b>	<b>\$ 400,000</b>

**City of Atwater**  
Fiscal Year 2025-26 Budget

**GENERAL PLAN UPDATE – HOUSING ELEMENT**

**Overview**

The general plan housing element update fund will be utilized to update the housing element. Funding from AB101 will be utilized.

**Revenues and Expenses:**

Account Number	Description	FY 2023-24 Unaudited	FY 2024-25 Amended Budget as of 3/24/25	FY 2025-26 BUDGET
1040-4010-3194	AB101-Housing Dev & Financing	\$ 74,606	\$ 75,394	\$ 25,394
	<b>Total Revenues</b>	<b>\$ 74,606</b>	<b>\$ 75,394</b>	<b>\$ 25,394</b>
1040-4010-3030	Professional Services	\$ 10,800	\$ 89,200	\$ 14,594
	<b>Total Expenditures</b>	<b>\$ 10,800</b>	<b>\$ 89,200</b>	<b>\$ 14,594</b>

**GENERAL PLAN UPDATE**

**Overview**

The general plan update fund will be utilized to fund the update of the City’s general plan document. Funding for the general plan update will come from a variety of sources including SB2.

**Revenues and Expenses:**

Account Number	Description	FY 2023-24 Unaudited	FY 2024-25 Amended Budget as of 3/24/25	FY 2025-26 BUDGET
1041-0000-6001	Interest Earned	\$ 51,236	\$ -	\$ -
1041-0000-8001	Trn Fr General Fund	\$ -	\$ -	\$ -
1041-0000-8005	Trn Fr Water Enterprise	\$ -	\$ -	\$ -
1041-0000-8006	Trn Fr Sewer Enterprise	\$ -	\$ -	\$ -
1041-4010-3195	SB2-Planning Grants	\$ 160,000	\$ -	
	<b>Total Revenues</b>	<b>\$ 211,236</b>	<b>\$ -</b>	<b>\$ -</b>
1041-1080-V017	Bellevue Road Realignment		\$ 353,840	\$ 353,840
1041-4010-3030	Professional Services	\$ 467,564	\$ 2,721,519	\$ 1,327,308
	Work Group 1 - De Novo			
	Work Group 2 - Rincon Regional Housing Element			
	Work Group 3 - Expansion of Circulation Element			
	Work Group 4 - Fiscal Analysis & Legal			
	Misc. professional services			
	<b>Total Expenditures</b>	<b>\$ 467,564</b>	<b>\$ 3,075,359</b>	<b>\$ 1,681,148</b>

# City of Atwater

## Fiscal Year 2025-26 Budget

### CDBG AND HOME GRANTS FUND

#### Overview

State funded Community Development Block Grants, HOME Grants, and CAL Home Grants help the city operate an Owner-Occupied Housing Rehabilitation Program and First Time Home Buyers Down Payment Assistance Program as well as fund various projects that benefit affordable housing. These programs/projects are augmented by local cash match often located in program income funds and or match through the Atwater Redevelopment Agency. The city manages the housing programs through the services of an outside program manager that is contracted for program administration, activity delivery, marketing, and loan portfolio management. The housing programs are designed to target persons of low and moderate income which need assistance to purchase and/or make repairs to their primary home. The securing of quality homes to these individuals helps to stabilize neighborhoods and maintain homes which might otherwise lead to blight and dilapidation. These budgets provide for the activities that will implement the following goals:

- Develop and implement strategies that seek to provide affordable housing.
- Actively seek grants to provide opportunities for low and moderate-income families to purchase homes through a first-time home buyer down payment assistance and make necessary repairs through an owner occupied housing rehabilitation program.
- Provide construction of off-site improvements or public improvements within the right of way within neighborhoods meeting income eligibility which have decaying or dilapidated infrastructure – in support of housing rehabilitation.

#### CDBG Program Income:

Account Number	Description	FY 2023-24 Unaudited	FY 2024-25 Amended Budget as of 3/24/25	FY 2025-26 BUDGET
1064-0000-6001	Interest Earned	\$ 8,129	\$ 500	\$ 500
1064-4065-6030	Loan Repayments	\$ 37,000	\$ -	\$ 6,000
1064-4067-6030	Loan Repayments	\$ 5,900	\$ -	\$ 25,000
	<b>Total Revenues</b>	<b>\$ 51,029</b>	<b>\$ 500</b>	<b>\$ 31,500</b>
1064-4067-3070	Loans & Grants (Rehab)	\$ 4,649	\$ -	\$ 180,603
1064-4067-3089	Activity Delivery Rehab	\$ 3,622	\$ -	\$ 27,649
	<b>Total Expenditures</b>	<b>\$ 8,271</b>	<b>\$ -</b>	<b>\$ 208,252</b>

City of Atwater  
Fiscal Year 2025-26 Budget

**CDBG AND HOME GRANTS FUND (cont.)**

**HOME Grant:**

Account Number	Description	FY 2023-24 Unaudited	FY 2024-25 Amended Budget as of 3/24/25	FY 2025-26 BUDGET
1078-0000-6001	Interest Earned	\$ 13,072	\$ -	\$ 1,200
1078-4077-6030	Loan Repayments		\$ -	
1078-4078-6030	Loan Repayments		\$ -	
1078-4086-3170	Grant Revenue - First-Time Homebuyer Program	\$ -	\$ -	
1078-4087-3170	Grant Revenue - Occupied Rehabilitation Program	\$ -	\$ -	
	<b>Total Revenues</b>	<b>\$ 13,072</b>	<b>\$ -</b>	<b>\$ 1,200</b>
1078-4078-3070	Loans & Grants (Rehab)	\$ -	\$ 100,645	\$ 100,645
1078-4078-3080	General Administration	\$ -	\$ 44,143	\$ 44,143
1078-4078-3088	Activity Delivery HB	\$ -	\$ 17,216	\$ 17,216
1078-1078-3089	Activity Delivery (Rehab)	\$ -	\$ 31,783	\$ 31,783
1078-4078-3091	Loans & Grants (HB)	\$ -	\$ 247,639	\$ 247,639
	<b>Total Expenditures</b>	<b>\$ -</b>	<b>\$ 441,426</b>	<b>\$ 441,426</b>

**PHLA-Perm Local Housing Alloc Grant:**

Account Number	Description	FY 2023-24 Unaudited	FY 2024-25 Amended Budget as of 3/24/25	FY 2025-26 BUDGET
1080-4043-3170	Grant Revenue	\$ 158,592	\$ 949,257	\$ 269,804
	<b>Total Revenues</b>	<b>\$ 158,592</b>	<b>\$ 949,257</b>	<b>\$ 269,804</b>
1080-4043-3030	Professional Services	\$ -	\$ 949,257	\$ 658,408
	<b>Total Expenditures</b>	<b>\$ -</b>	<b>\$ 949,257</b>	<b>\$ 658,408</b>

City of Atwater  
Fiscal Year 2025-26 Budget

**POLICE FACILITY IMPACT FEES FUND**

**Overview**

In order to implement the goals and objectives of the Capital Improvement Program and to mitigate the growth as impacts caused by new development in the City of Atwater, certain public facilities must be improved or expanded. The City Council has determined that various development impact fees are needed in order to finance these public improvements and to pay for the development's fair share of the construction costs of these sections, the City Council has found the fee to be consistent with it's General Plan.

The Police Impact Fees fund was established in 1995 to account for the revenues and expenditures related to the facility impact fees and improvements.

**Revenues and Expenses:**

Account Number	Description	FY 2023-24 Unaudited	FY 2024-25 Amended Budget as of 3/24/25	FY 2025-26 BUDGET
1091-0000-1077	Police Facility Impact Fee	\$ 4,194	\$ 4,000	\$ 4,000
1091-0000-6001	Interest Earned	\$ 5,069	\$ 500	\$ 500
	<b>Total Revenues</b>	<b>\$ 9,263</b>	<b>\$ 4,500</b>	<b>\$ 4,500</b>
1091-2020-6021	Machinery & Equipment	\$ -	\$ -	\$ -
	Dispatch Workstations			
1091-2021-6021	Machinery & Equipment	\$ 78,483	\$ -	\$ -
	Vehicle Purchase - Patrol SUV encumbered FY 22/23			
	Vehicle Purchase - 2 Electric Pickups encumbered FY 22/23			
	<b>Total Expenditures</b>	<b>\$ 78,483</b>	<b>\$ -</b>	<b>\$ -</b>

City of Atwater  
Fiscal Year 2025-26 Budget

**FIRE FACILITY IMPACT FEES FUND**

**Overview**

In order to implement the goals and objectives of the Capital Improvement Program and to mitigate the growth as impacts caused by new development in the City of Atwater, certain public facilities must be improved or expanded. The City Council has determined that various development impact fees are needed in order to finance these public improvements and to pay for the development's fair share of the construction costs of these sections, the City Council has found the fee to be consistent with it's General Plan.

The Fire Facility Impact Fees fund was established in 1995 to account for the revenues and expenditures related to the facility impact fees and improvements.

**Revenues and Expenses:**

Account Number	Description	FY 2023-24 Unaudited	FY 2024-25 Amended Budget as of 3/24/25	FY 2025-26 BUDGET
1093-0000-1078	Fire Facility Impact Fee	\$ 5,439	\$ 3,640	\$ 3,640
1093-0000-6001	Interest Earned	\$ 7,000	\$ 700	\$ 500
	<b>Total Revenues</b>	<b>\$ 12,439</b>	<b>\$ 4,340</b>	<b>\$ 4,140</b>
1093-2030-3099	Miscellaneous	\$ 135	\$ 170	\$ 170
	<b>Total Expenditures</b>	<b>\$ 135</b>	<b>\$ 170</b>	<b>\$ 170</b>

**City of Atwater**  
Fiscal Year 2025-26 Budget

**GOVERNMENT BUILDING FACILITY FUND**

**Overview**

In order to implement the goals and objectives of the Capital Improvement Program and to mitigate the growth as impacts caused by new development in the City of Atwater, certain public facilities must be improved or expanded. The City Council has determined that various development impact fees are needed in order to finance these public improvements and to pay for the development's fair share of the construction costs of these sections, the City Council has found the fee to be consistent with it's General Plan.

The Government Building Facility fund was established to account for the revenues and expenditures related to the facility impact fees and improvements.

**Revenues:**

Account Number	Description	FY 2023-24 Unaudited	FY 2024-25 Amended Budget as of 3/24/25	FY 2025-26 BUDGET
1095-0000-1072	Govt. Building Facility Tax	\$ 4,596	\$ 4,000	\$ 4,000
1095-0000-6001	Interest Earned	\$ 7,476	\$ 500	\$ 500
	<b>Total Revenues</b>	<b>\$ 12,072</b>	<b>\$ 4,500</b>	<b>\$ 4,500</b>

# City of Atwater

## Fiscal Year 2025-26 Budget

### PENSION RATE STABILIZATION 115 TRUST FUND

#### Overview

PARS is the Trust Administrator for the Public Agencies Post-Employment Benefits Trust. The PARS Pension Rate Stabilization Program (PRSP) is a Section 115 irrevocable trust designed for agencies to prefund rising pension costs and address pension liabilities. The Trust is used by the City to make its future contributions to CalPERS and therefore, the cash is still the City's cash but it is restricted as to its use. The City is the beneficiary of the trust to help it make the contribution to CalPERS. In addition to pension, the City is prefunding retiree health care (OPEB) liabilities within the same trust. This is accounted for separately as an expenditure in the Employee Benefits Fund.

#### Revenues and Expenses:

Account Number	Description	FY 2023-24 Unaudited	FY 2024-25 Amended Budget as of 3/24/25	FY 2025-26 BUDGET
4080-0000-6000	Accrued Interest Earned	\$ 47,348	\$ -	\$ -
4080-0000-8060	Transf From Emp Benefits Fund	\$ 100,000	\$ 50,000	\$ 50,000
	<b>Total Revenues</b>	<b>\$ 147,348</b>	<b>\$ 50,000</b>	<b>\$ 50,000</b>

# City of Atwater

## Fiscal Year 2025-26 Budget

### MAINTENANCE DISTRICTS

#### Overview

These budgets provide facility maintenance and operations for the residents within special districts. Maintenance districts provide for street lighting, storm drainage and in some cases for the continuing care of the landscaping in the common areas in the district.

#### Objectives

- Provide maintenance of City streets alley ways, sidewalks and parking lots.
- Provide maintenance and repair of Assessment districts street lighting, storm drainage and landscape areas.

#### Revenues and Expenses:

Account Number	Description	FY 2024-25 Amended Budget as of 3/24/25	FY 2025-26 BUDGET
5000-0000-4071	Assessment District Fees	\$ 203,304	\$ 203,304
5000-0000-6001	Interest Earned	\$ 3,000	\$ 3,000
5000-0000-8001	Trn Fr General Fund	\$ 141,065	\$ 145,000
	<b>Total Revenues</b>	<b>\$ 347,369</b>	<b>\$ 351,304</b>
5000-3038-2021	Special Departmental Expense	\$ 30,000	\$ 30,000
	Upgrades & Improvements to Pumps/Impellers		
5000-3038-2023	Small Tools	\$ 300	\$ 300
	Rakes, shovels, hoses and bibs		
5000-3038-2027	Maint Dist Lndscp Expense	\$ 17,000	\$ 17,000
	Landscape & Irrigation Improvements		
	Irrigation Control Boxes		
	Herbicides and Pesticides		
	Horticulture Expenses		
	Parts & Repairs to Power Tools & Equip.		
	Sprinkler Repairs		
5000-3038-3001	City Administration Fees - Salary Alloc.	\$ 106,243	\$ 95,987
5000-3038-3030	Professional Services	\$ 185,354	\$ 185,354
	Annual Assessment		
	Update Engineer's Reports		
	NPDES Annual Permit		
	Streetlight Maintenance Service		
	Mowing and Weed Control		
	Motor and Pump Repair		
	Graffiti Removal		
	Landscape Services		
5000-3038-3031	Communications	\$ -	
5000-3038-3032	Utilities	\$ 105,000	\$ 105,000
	Electric Charges		
	Irrigation Charges		
	<b>Total Expenditures</b>	<b>\$ 443,897</b>	<b>\$ 433,641</b>

# City of Atwater

## Fiscal Year 2025-26 Budget

### **COMMUNITY FACILITIES DISTRICT**

#### **Overview**

Police and Fire Operations create and maintain security in the community and the department works with the citizens of Atwater to provide the best public safety service possible; to provide twenty-four hour patrol service for the community, respond to all Calls for Service, resolve conflicts, and identify potential problems of a serious nature. Police Operations goals include enforcing state laws and applicable city ordinances in a fair and courteous manner and providing community relations for crime prevention and crime reduction.

#### **Objectives**

- Law enforcement officers will respond to emergency situations within an average of less than 3 minutes.
- Fill vacancies and continue to organize department to best serve the community.
- Continue to look at technology to assist the department in providing service to the community.
- Continue to work to decrease gang activity within the City.
- Work with City leaders to find ways to resolve homeless issues in Atwater.

City of Atwater  
Fiscal Year 2025-26 Budget

**COMMUNITY FACILITIES DISTRICT**

**Revenues and Expenses:**

Account Number	Description	FY 2023-24 Unaudited	FY 2024-25 Amended Budget as of 3/24/25	FY 2025-26 BUDGET	FY 2025-26 Details
5050-0000-4071	Assessment District Fees	\$ 662,481	\$ 694,000	\$ 721,760	
5050-0000-6001	Interest Earned	\$ 248	\$ -	\$ 500	
5050-0000-XXXX	Trn Fr General Fund		\$ 141,065	\$ 160,821	
	<b>Total Revenues</b>	<b>\$ 662,729</b>	<b>\$ 835,065</b>	<b>\$ 883,081</b>	
5050-2021-1001	Salaries & Wages, Regular	\$ 241,499	\$ 291,722	\$ 306,159	
	Police Sergeant				\$ 124,980
	Police Officer				\$ 86,173
	Police Officer (Detective)				\$ 95,006
5050-2021-1003	Leave Accrual Buy-Out	\$ 7,425	\$ 10,832	\$ 11,372	
5050-2021-1004	Overtime	\$ 22,900	\$ 30,000	\$ 30,000	
5050-2021-1005	Holiday Pay	\$ 18,109	\$ 22,748	\$ 23,882	
5050-2021-1006	Stand By Pay	\$ 1,925		\$ 9,100	
5050-2021-1007	Special Duty	\$ 1,798	\$ 4,200	\$ 4,524	
5050-2021-1008	In-Lieu Of Insurance Benefit	\$ 7,200	\$ 7,200	\$ 7,200	
5050-2021-1012	Fica/Medicare	\$ 22,728	\$ 27,249	\$ 30,006	
5050-2021-1013	Retirement	\$ 158,151	\$ 175,966	\$ 192,772	
5050-2021-1014	Health Insurance	\$ 20,419	\$ 18,995	\$ 47,476	
5050-2021-1015	Worker's Compensation	\$ 19,962	\$ 26,389	\$ 28,944	
5050-2021-4088	Risk Management Charges	\$ 50,439	\$ 74,474	\$ 80,341	
5050-2021-4089	Employee Benefits Charges	\$ 9,226	\$ 10,504	\$ 11,062	
5050-2021-6021	Machinery & Equipment		\$ -		
5050-2030-3030	Professional Services	\$ 100,000	\$ 100,000	\$ 100,000	
	CAL FIRE Agreement (partial)				
	<b>Total Expenditures</b>	<b>\$ 681,781</b>	<b>\$ 800,279</b>	<b>\$ 882,838</b>	

**City of Atwater**  
Fiscal Year 2025-26 Budget

**WATER ENTERPRISE FUNDS**

**Overview**

Under the direction of the Public Works Director, maintain the City's water productions and distribution system; provide sufficient quantities of potable drinking water for the community; improve existing water well systems and water quality; improve distribution control and continue the fire hydrant replacement program. The funds included in this budget are the Water Enterprise Fund, Water Capital Replacement Fund, DBCP Settlement Fund and 1,2,3-TCP Fund.

**Objectives**

- Provide maintenance and repair of City's Water Wells.
- Provide maintenance and repair of City's Water Well Distribution system.
- Provide Water sampling and testing as required.
- To maintain debt service requirements and capital needs of the Water Enterprise Fund.

**Revenues:**

Account Number	Description	FY 2023-24 Unaudited	FY 2024-25 Amended Budget as of 3/24/25	FY 2025-26 BUDGET
6000-0000-4051	Water Service Charges	\$ 8,398,535	\$ 8,200,000	\$ 8,400,000
6000-0000-4052	Water Connection Fees	\$ -	\$ 1,000	\$ 1,000
6000-0000-6001	Interest Earned	\$ 454,916	\$ 2,500	\$ 40,000
6000-0000-6041	Delinquent Fee	\$ 12,840	\$ 20,000	\$ 20,000
6000-0000-6091	Other Revenue	\$ 29,019	\$ 10,000	\$ 10,000
	<b>Total Revenues</b>	<b>\$ 8,895,310</b>	<b>\$ 8,233,500</b>	<b>\$ 8,471,000</b>

# City of Atwater

## Fiscal Year 2025-26 Budget

### WATER ENTERPRISE FUNDS

#### Expenses:

Account Number	Description	FY 2023-24 Unaudited	FY 2024-25 Amended Budget as of 3/24/25	FY 2025-26 BUDGET	FY 2025-26 Details
6000-1050-3030	Professional Services	\$ 6,370	\$ 12,500	\$ 12,500	
	Attorney Legal Services				\$ 12,500
6000-7000-3001	City Administration Fees - Incl. Internal Service Operations & Salary Alloc.	\$ 1,574,164	\$ 1,657,367	\$ 1,695,287	
6000-7010-1001	Salaries & Wages, Regular	\$ 407,190	\$ 437,535	\$ 527,173	
	Water Division Supervisor				\$ 87,384
	Water Systems Pump Operator				\$ 60,860
	Water Systems Operator II				\$ 59,315
	Water Systems Operator I				\$ 44,344
	Water Systems Operator I				\$ 51,333
	Water Systems Operator I				\$ 46,561
	Water Systems Operator I				\$ 44,344
	Water Systems Operator I				\$ 44,344
	Water Systems Operator I				\$ 44,344
	Water Systems Operator I				\$ 44,344
6000-7010-1002	Salaries & Wages, Parttime	\$ -	\$ -		
6000-7010-1003	Leave Accrual Buy-Out	\$ 21,190	\$ 7,621	\$ 8,402	
6000-7010-1004	Overtime	\$ 16,030	\$ 30,000	\$ 30,000	
6000-7010-1006	Stand By Pay	\$ 11,499	\$ 21,000	\$ 35,000	
6000-7010-1008	In-Lieu Of Insurance Benefit	\$ 19,870	\$ 28,800	\$ 9,600	
6000-7010-1012	Fica/Medicare	\$ 33,964	\$ 40,159	\$ 46,678	
6000-7010-1013	Retirement	\$ 148,202	\$ 141,719	\$ 173,774	
6000-7010-1014	Health Insurance	\$ 62,857	\$ 53,187	\$ 154,813	
6000-7010-1015	Worker's Compensation	\$ 33,701	\$ 38,891	\$ 40,230	
6000-7010-1024	Additional Duty		\$ -		
6000-7010-2020	Office Supplies	\$ 20,857	\$ 20,400	\$ 23,000	
	Postage for Utility Billing (1/3 ea. Water/Sewer/Garbage)				
	Office Supplies				
6000-7010-2021	Special Departmental Expense	\$ 205,187	\$ 210,600	\$ 221,130	
	Distribution Repair Parts				\$ 136,500
	Chlorine				\$ 47,250
	Cold Patch				\$ 15,750
	Water Meter Software Upgrade				\$ 6,300
	First Aid Supplies				\$ 1,155
	Diesel Fuel for Well Generator				\$ 1,050
	Backflow Parts				\$ 13,125
6000-7010-2023	Small Tools	\$ 5,755	\$ 6,000	\$ 6,300	
6000-7010-2024	Uniform & Clothing Expense	\$ 8,482	\$ 9,000	\$ 9,450	
	Boots, PPE				
6000-7010-3030	Professional Services	\$ 376,952	\$ 721,550	\$ 723,400	
	Printing and Mailing Utility Billing (1/3 ea. Water/Sewer/Garbage)				\$ 13,000
	Fire Extinguisher Maint				\$ 2,100
	Water Line Installations				\$ 47,000
	Pump Repairs				\$ 31,500
	IT Support (Sensus Software)				\$ 8,400
	Well Maintenance				\$ 36,500
	Water Quality Test				\$ 63,000
	Permit Fees				\$ 23,100
	DOT/ Physical Exams				\$ 1,100
	Tesco Services				\$ 66,150
	Haz-Mat Compliance				\$ 5,250
	SGMA				\$ 6,300
	Water Master Plan				\$ 262,500
	Staff Augmentation				\$ 157,500

City of Atwater  
Fiscal Year 2025-26 Budget

**WATER ENTERPRISE FUNDS (cont.)**

**Expenses:**

Account Number	Description	FY 2023-24 Unaudited	FY 2024-25 Amended Budget as of 3/24/25	FY 2025-26 BUDGET	FY 2025-26 Details
6000-7010-3031	Communications	\$ 10,483	\$ 13,800	\$ 14,490	
	AT&T - Alarm Lines				\$ 3,675
	Cell Phones				\$ 7,665
	Radio Announcements				\$ 3,150
6000-7010-3032	Utilities	\$ 1,624,709	\$ 2,036,075	\$ 1,909,682	
6000-7010-3033	Printing & Advertising	\$ 230	\$ 2,000	\$ 2,000	
	Legal Notices/Advertising				
6000-7010-3034	Rents & Leases	\$ 1,508	\$ 2,200	\$ 2,200	
	Copier Lease				
6000-7010-3035	Operations & Maintenance	\$ 896	\$ 1,100	\$ 1,100	
	Copier Usage Fees				
6000-7010-3036	Memberships & Subscriptions	\$ 253	\$ 2,755	\$ 2,895	
	Springbrook CivicPay Subscription-Utility Phone Payments				\$ 2,160
	Miscellaneous				\$ 735
6000-7010-3037	Travel/Conferences/Meetings	\$ -	\$ 1,850	\$ 1,950	
	Recertification, Electrical Courses, Etc.				\$ 375
	League of CA Cities-Public Works				\$ 525
	Misc. Training Travel				\$ 1,050
6000-7010-3038	Training	\$ 1,451	\$ 6,170	\$ 6,480	
	Recertification, Electrical Courses, Etc.				\$ 1,755
	League of CA Cities-Public Works				\$ 525
	Distribution Certifications/Pesticide Courses, Safety Courses, etc.				\$ 4,200
6000-7010-3090	Depreciation Expense	\$ 171,204	\$ -		
6000-7010-3096	Bad Debt Expense	\$ (14,588)	\$ -	\$ -	
6000-7010-3102	Electronic Pmt Processing Exp	\$ 32,660	\$ 30,950	\$ 33,000	
	Utility Web Payment-Bluefin				
	Utility Bill Pay - Vanco				
	Utility Phone Payment - Springbrook				
6000-7010-4041	Equipment Maint. Charges	\$ 105,942	\$ 106,078	\$ 106,808	
6000-7010-4045	Building Maint. Charges	\$ 32,462	\$ 29,972	\$ 28,560	
6000-7010-4087	Information Technology Charges	\$ 49,476	\$ 48,391	\$ 71,268	
6000-7010-4088	Risk Management Charges	\$ 68,827	\$ 96,698	\$ 119,177	
6000-7010-4089	Employee Benefits Charges	\$ 88,388	\$ 99,412	\$ 116,708	
6000-7010-4090	Fixed Asset Disposal	\$ 3,188			
6000-7010-6021	Machinery & Equipment	\$ 1	\$ 335,000	\$ 125,000	
	Lease for Vaccon Truck				\$ 125,000
6000-9095-9050	Trn To General Fund	\$ 152,375	\$ 152,375	\$ 152,375	
6000-9095-9068	Transf to Water Capital Fund	\$ 1,642,245	\$ -	\$ -	
	<b>Total Expenditures</b>	<b>\$ 6,923,980</b>	<b>\$ 6,401,155</b>	<b>\$ 6,410,430</b>	

City of Atwater  
Fiscal Year 2025-26 Budget

**WATER ENTERPRISE FUNDS**  
**Water Fund Capital Replacement**

**Revenues and Expenses:**

Account Number	Description	FY 2023-24 Unaudited	FY 2024-25 Amended Budget as of 3/24/25	FY 2025-26 BUDGET
6001-0000-6001	Interest Earned	\$ 8,330	\$ 5,000	\$ 5,000
6001-0000-6093	Transf from Water Enterprise	\$ 1,642,245		
	<b>Total Revenues</b>	<b>\$ 1,650,575</b>	<b>\$ 5,000</b>	<b>\$ 5,000</b>
6001-1080-3090	Depreciation Expense	\$ 6,447	\$ -	
6001-1080-E017	Well Control Panel Upgrade	\$ -	\$ -	
6001-1080-H008	Hydrant Replacement	\$ 65,651	\$ 75,000	\$ 75,000
6001-1080-H015	Well #20A Rehab	\$ 1,347,209	\$ 1,639,175	
6001-1080-L014	Installation-New Water Meters	\$ 1,768,112	\$ 3,200,000	\$ 600,000
6001-1080-N002	Water Meter Software Upgrade			
6001-1080-T003	Water Tower Painting			
6001-1080-V011	Property Acq.-Future Well Site	\$ 6,325	\$ 300,000	
6001-1080-V042	Water Tower Lights Install			
6001-1080-W006	Canal Creek Utility Crossing	\$ 29,396	\$ 250,000	\$ 250,000
	<b>Total Expenditures</b>	<b>\$ 3,223,140</b>	<b>\$ 5,464,175</b>	<b>\$ 925,000</b>

**Water Capital Impact Fees**

6005-0000-4052	Water Connection Fees	\$ 5,200	\$ 1,200	
6005-0000-4067	Capacity Fee	\$ 63,160	\$ 17,050	
6005-0000-6001	Interest Earned	\$ 72,034	\$ -	\$ 10,000
	<b>Total Revenues</b>	<b>\$ 140,394</b>	<b>\$ 18,250</b>	<b>\$ 10,000</b>
6005-1080-3090	Depreciation Expense	\$ 15,001	\$ -	
	<b>Total Expenditures</b>	<b>\$ 15,001</b>	<b>\$ -</b>	<b>\$ -</b>

**Water Operating Reserve Fund**

6006-0000-6001	Interest Earned	\$ 4,797	\$ -	\$ 500
	<b>Total Revenues</b>	<b>\$ 4,797</b>	<b>\$ -</b>	<b>\$ 500</b>

**1,2,3-TCP Fund**

**Revenues and Expenses:**

Account Number	Description	FY 2023-24 Unaudited	FY 2024-25 Amended Budget as of 3/24/25	FY 2025-26 BUDGET	FY 2025-26 Details
6007-0000-6001	Interest Earned	\$ 1,343,038	\$ 25,000	\$ 25,000	
	<b>Total Revenues</b>	<b>\$ 1,343,038</b>	<b>\$ 25,000</b>	<b>\$ 25,000</b>	
6007-1080-H010	TCP Well Rehab				
6007-1080-H015	Well #20A Rehab	\$ 2,021,160	\$ 649,640		
6007-7010-3030	Professional Services	\$ 925,148	\$ 1,500,000	\$ 1,500,000	
	Lab Samples				\$ 100,000
	Carbon Change-Outs				\$ 1,400,000
	<b>Total Expenditures</b>	<b>\$ 2,946,308</b>	<b>\$ 2,149,640</b>	<b>\$ 1,500,000</b>	

# City of Atwater

## Fiscal Year 2025-26 Budget

### **WASTEWATER ENTERPRISE FUNDS**

#### **Overview**

Under direction of the Public Works Director, this department is responsible for maintaining all City sewer mains, lines and lift stations in a manner that will assure uninterrupted, safe service; to maintain lift stations and main lines at intervals that promote good service; to see that employees work safely and effectively when working in confined spaces.

The department is also responsible for maintenance and operation of the City's Wastewater Treatment Facility and the management of the service agreement for operations management by Veolia Environmental Services. This activity is also responsible for meeting the debt service requirements of the Sewer Enterprise Fund and its capital needs for facility repair and maintenance.

#### **Objectives**

- Provide high level of service for the uninterrupted flow of wastewater to the wastewater treatment plant.
- Provide maintenance and repair of City's Sewer lift Stations.
- Provide maintenance and repair of City's Sewer Distribution system.
- Provide Sewer sampling and testing as required.
- To maintain debt service requirements and capital needs of the Wastewater Enterprise Fund.
- Provide street sweeping services and insuring clean and safe City streets.
- Leaf pick up services to keep catch basins clear to prevent flooding and prevent dissolved oxygen to enter into the storm water system.

**City of Atwater**  
Fiscal Year 2025-26 Budget

**WASTEWATER ENTERPRISE FUNDS**

**Revenues:**

Account Number	Description	FY 2023-24 Unaudited	FY 2024-25 Amended Budget as of 3/24/25	FY 2025-26 BUDGET	FY 2025-26 Details
6010-0000-3012	SJVAPCD Grant	\$ -	\$ -	\$ -	
6010-0000-4053	Sewer Service Charges	\$ 12,040,786	\$ 11,800,000	\$ 11,923,000	
6010-0000-4057	Bop Maintenance Charges	\$ 55,000	\$ 55,000	\$ 55,000	
6010-0000-4058	Sewer Trunk Line Fee	\$ 8,598	\$ 8,500	\$ 8,500	
6010-0000-4060	Castle Sewer Interceptor		\$ -		
6010-0000-4140	Admin Fees, General Fund - Salary Alloc.	\$ 86,543	\$ 87,052	\$ 85,827	
6010-0000-4141	Admin Fees, Streets - Salary Alloc.	\$ 50,606	\$ 51,174	\$ 49,069	
6010-0000-4142	Admin Fees, Water - Salary Alloc.	\$ 184,821	\$ 187,936	\$ 174,910	
6010-0000-4143	Admin Fees, Sanitation - Salary Alloc.	\$ 90,797	\$ 93,562	\$ 80,827	
6010-0000-4145	Admin Fees, Maintenance Dist - Salary Alloc.	\$ 18,482	\$ 18,794	\$ 17,491	
6010-0000-6001	Interest Earned	\$ 399,386	\$ 40,000	\$ 4,000	
6010-0000-6002	Bond Interest Earned	\$ 100,053	\$ 300		
6010-0000-6091	Other Revenue	\$ 14,098	\$ 7,000		
	<b>Total Revenues</b>	<b>\$ 13,049,170</b>	<b>\$ 12,349,318</b>	<b>\$ 12,398,624</b>	

**Expenses:**

Account Number	Description	FY 2023-24 Unaudited	FY 2024-25 Amended Budget as of 3/24/25	FY 2025-26 BUDGET	FY 2025-26 Details
6010-1050-3030	Professional Services	\$ 9,626	\$ 67,500	\$ 25,000	
	Attorney Legal Services				\$ 15,000
	Financial Advisor Services				\$ 10,000
6010-1080-3090	Depreciation Expense	\$ 2,409,996	\$ -		
6010-1080-H011	Sewer Lift Station Imprvmnts	\$ 7,619	\$ -		
6010-1080-M007	Fruitland Ave Rd Improvements		\$ -		
6010-1080-V016	Industry Stat CMU Wall Install		\$ -		
6010-1080-W006	Canal Creek Utility Crossing	\$ 28,038	\$ 250,000	\$ 250,000	
6010-1080-W007	Castle Sewer Interceptor	\$ 42,375	\$ 1,900,000	\$ 1,950,000	
6010-1080-W008	Property Acq-998 Atwater Blvd	\$ 18,000	\$ -		
6010-1080-W009	Lower Shaffer Storm Drain Imp	\$ 353,228	\$ 3,000,000	\$ 6,000,000	
6010-1080-X011	Atwater Blvd Drainage Improvements	\$ 104,425	\$ 200,000	\$ 100,000	
6010-1080-X012	Eucalyptus and First St Drainage Improvements	\$ 112,500	\$ 300,000		
6010-5050-3001	City Administration Fees	\$ 1,246,188	\$ 1,308,044	\$ 1,380,921	
6010-5050-5031	Principal-2017 Wastewater Bond		\$ 1,115,000	\$ 1,175,000	
6010-5050-5032	Interest-2017 Wastewater Bond	\$ 2,423,304	\$ 2,191,838	\$ 2,136,088	
6010-5050-5033	Principal-2018 Wastewater Bond		\$ 715,000	\$ 740,000	
6010-5050-5034	Interest-2018 Wastewater Bond	\$ 190,367	\$ 426,369	\$ 397,769	

City of Atwater  
Fiscal Year 2025-26 Budget

**WASTEWATER ENTERPRISE FUNDS (cont.)**

**Expenses:**

Account Number	Description	FY 2023-24 Unaudited	FY 2024-25 Amended Budget as of 3/24/25	FY 2025-26 BUDGET	FY 2025-26 Details
6010-5051-1001	Salaries & Wages, Regular	\$ 815,213	\$ 833,924	\$ 818,703	
	Public Works Director				\$ 160,023
	Public Works Superintendent				\$ 111,671
	Sewer Division Supervisor				\$ 80,845
	Administrative Assistant I				\$ 40,067
	Sewer Maint Worker II				\$ 60,515
	Sewer Maint Worker II				\$ 59,315
	Sewer Maint Worker I				\$ 53,900
	Sewer Maint Worker I				\$ 53,900
	Sewer Maint Worker I				\$ 53,900
	Sewer Maint Worker I				\$ 44,344
	Sewer Maint Worker I				\$ 51,333
	Sewer Maint Worker I				\$ 48,889
6010-5051-1002	Salaries & Wages, Parttime	\$ -	\$ -		
6010-5051-1003	Leave Accrual Buy-Out	\$ 34,393	\$ 31,847	\$ 35,111	
6010-5051-1004	Overtime	\$ 41,730	\$ 50,000	\$ 50,000	
6010-5051-1006	Stand By Pay	\$ 11,420	\$ 14,000	\$ 14,000	
6010-5051-1008	In-Lieu Of Insurance Benefit	\$ 16,110	\$ 36,000	\$ 14,400	
6010-5051-1012	Fica/Medicare	\$ 66,613	\$ 74,771	\$ 70,493	
6010-5051-1013	Retirement	\$ 327,451	\$ 302,452	\$ 305,621	
6010-5051-1014	Health Insurance	\$ 134,300	\$ 132,503	\$ 188,430	
6010-5051-1015	Worker's Compensation	\$ 64,679	\$ 72,410	\$ 68,791	
6010-5051-1024	Additional Duty	\$ -	\$ 11,623		
6010-5051-2020	Office Supplies	\$ 20,857	\$ 17,900	\$ 23,000	
	Postage for Utility Billing (1/3 ea. Water/Sewer/Garbage)				
	Office Supplies				
6010-5051-2021	Special Departmental Expense	\$ 102,186	\$ 151,600	\$ 157,180	
	Parts for Repair of Sewer Lift Stations				\$ 42,000
	Pump Motor for Sewer Lift Station				\$ 52,500
	Cold Patch				\$ 15,750
	Pipe & Fittings for Sewer Lateral Repair				\$ 10,500
	Sidewalk Curb and Gutter Replacement				\$ 21,000
	Oil & Lube for Lift Stations				\$ 630
	Chemical Weed Abatement				\$ 7,350
	Parts for Repair of Storm Stations				\$ 7,450
6010-5051-2023	Small Tools	\$ 5,013	\$ 8,000	\$ 8,000	
	Shovels, Rakes, Brooms, Misc. Hand Tools				\$ 8,000

**City of Atwater**  
Fiscal Year 2025-26 Budget

**WASTEWATER ENTERPRISE FUNDS (cont.)**

**Expenses:**

Account Number	Description	FY 2023-24 Unaudited	FY 2024-25 Amended Budget as of 3/24/25	FY 2025-26 BUDGET	FY 2025-26 Details
6010-5051-2024	Uniform & Clothing Expense	\$ 10,954	\$ 16,100	\$ 16,100	
	Safety Boots				\$ 3,000
	Gloves: Rubber and Leather				\$ 1,200
	Reflective Jackets				\$ 1,200
	Rain Gear/ Clothing				\$ 1,200
	Misc. Safety Supplies				\$ 1,000
	Uniform Cleaning				\$ 8,500
6010-5051-3030	Professional Services	\$ 163,588	\$ 545,600	\$ 541,600	
	Printing and Mailing Utility Billing (1/3 ea. Water/Sewer/Garbage)				\$ 13,000
	Gas Detector Maintenance				\$ 600
	Hot Patch Asphalt				\$ 20,000
	Electrical Repair				\$ 10,000
	Engineering Services				\$ 200,000
	Sewer and Storm Pump Repair				\$ 15,000
	Sewer Master Plan				\$ 157,500
	Sewer Rate Study				\$ 60,000
	Sewer Lateral Repair Reimbursement				\$ 20,000
	Sewer Mainline Repair				\$ 20,000
	Storm Drain/Storm Main Repair				\$ 10,000
	Flow Meter Calibration				\$ 15,000
	Storm Sampling				\$ 500
6010-5051-3031	Communications	\$ 11,776	\$ 19,000	\$ 19,000	
	AT&T				\$ 8,500
	Cell Phones				\$ 7,500
	Radio Announcements				\$ 3,000
6010-5051-3032	Utilities	\$ 93,337	\$ 64,000	\$ 70,400	
	Merced Irrigation District				\$ 4,400
	Pacific Gas and Electric				\$ 66,000
6010-5051-3034	Rents & Leases	\$ 1,508	\$ 5,000	\$ 5,000	
	Copier Lease				\$ 5,000
6010-5051-3036	Memberships & Subscriptions	\$ 253	\$ 3,183	\$ 3,288	
	CWEA Membership Fees				\$ 1,128
	Springbrook CivicPay Subscription-Utility Phone Payments				\$ 2,160
6010-5051-3037	Travel/Conferences/Meetings	\$ 675	\$ 850	\$ 895	
	Recertification, Electrical Courses, Etc.				\$ 370
	League of CA Cities-Public Works				\$ 525
6010-5051-3038	Training	\$ -	\$ 2,170	\$ 2,295	
	Recertification, Electrical Courses, Etc.				\$ 1,770
	League of CA Cities-Public Works				\$ 525
6010-5051-3090	Depreciation Expense	\$ 373,670	\$ -		
6010-5051-3096	Bad Debt Expense	\$ (15,282)	\$ -		
6010-5051-3102	Electronic Pmt Processing Exp	\$ 32,660	\$ 30,950	\$ 33,000	
	Utility Web Payment-Bluefin				
	Utility Bill Pay - Vanco				
	Utility Phone Payment - Springbrook				

City of Atwater  
Fiscal Year 2025-26 Budget

**WASTEWATER ENTERPRISE FUNDS (cont.)**

**Expenses:**

Account Number	Description	FY 2023-24 Unaudited	FY 2024-25 Amended Budget as of 3/24/25	FY 2025-26 BUDGET	FY 2025-26 Details
6010-5051-4041	Equipment Maint. Charges	\$ 289,376	\$ 290,023	\$ 289,048	
6010-5051-4045	Building Maint. Charges	\$ 32,462	\$ 29,972	\$ 28,560	
6010-5051-4087	Information Technology Charges	\$ 32,984	\$ 32,261	\$ 55,431	
6010-5051-4088	Risk Management Charges	\$ 140,981	\$ 188,760	\$ 181,908	
6010-5051-4089	Employee Benefits Charges	\$ 41,646	\$ 44,568	\$ 46,031	
6010-5051-4090	Fixed Asset Disposal	\$ 3,188			
6010-5051-6021	Machinery & Equipment	\$ 1	\$ 120,000		
6010-5051-6031	Improvements Other Than Bldg	\$ -	\$ -		
6010-5051-XXXX	Electric Street Sweeper	\$ -	\$ -	\$ 151,000	
6010-5052-2021	Special Departmental Expense	\$ 58,510	\$ 65,000	\$ 70,000	
	Misc. Permit Fees (State/County/SJVAPCD, etc.)				\$ 70,000
6010-5052-3030	Professional Services	\$ 2,436,712	\$ 2,393,287	\$ 2,457,197	
	Plant Management Services (Veolia)				\$ 2,356,873
	Support for Permit Compliance				\$ 20,000
	Dried Sludge Removal				\$ 26,000
	Annual Veolia Contract Adjustment				\$ 34,324
	IPP Implementation				\$ 20,000
6010-5052-3032	Utilities	\$ 1,009,548	\$ 985,000	\$ 985,000	
	Solar for WWTP				\$ 305,000
	MID Power for WWTP				\$ 80,000
	PG&E for WWTP				\$ 600,000
6010-5052-3090	Depreciation Expense	\$ 45,562	\$ -		
6010-5052-6021	Machinery & Equipment	\$ 36,626	\$ 228,000	\$ 447,300	
	Repair Influent Pumps (2)				\$ 110,000
	Vactor Station Pump				\$ 25,000
	Replacement media for 1 of 3 tertiary filters				\$ 24,000
	UV Lamp Replacement				\$ 160,000
	Replace Gear box and Auger Muffin Monster				\$ 24,300
	Replace Rooftop A/C				\$ 29,000
	Replace Walmount A/C				\$ 24,000
	Repair/Replace Admin Roof				\$ 42,000
	Fire Pump Panel				\$ 9,000
6010-9095-9086	Transf To Gen Plan Update Fund	\$ -	\$ -		
	<b>Total Expenditures</b>	<b>\$ 13,386,366</b>	<b>\$ 18,274,505</b>	<b>\$ 21,311,560</b>	

City of Atwater  
Fiscal Year 2025-26 Budget

**Wastewater Fund Capital Replacement**

**Revenues and Expenses:**

Account Number	Description	FY 2023-24 Unaudited	FY 2024-25 Amended Budget as of 3/24/25	FY 2025-26 BUDGET
6011-0000-4054	Sewer Connection Fees	\$ 4,400	\$ 4,800	
6011-0000-4067	Capacity Fee	\$ 53,661	\$ 30,000	
6011-0000-4068	Sewer WWTP Expansion	\$ -	\$ 5,000	
6011-0000-6001	Interest Earned	\$ 100,237	\$ 10,000	\$ 10,000
6011-0000-6091	Other Revenue	\$ 1,947	\$ 1,000	
	<b>Total Revenues</b>	<b>\$ 160,245</b>	<b>\$ 50,800</b>	<b>\$ 10,000</b>
6011-1080-3090	Depreciation Expense	\$ 138,902	\$ -	
	<b>Total Expenditures</b>	<b>\$ 138,902</b>	<b>\$ -</b>	<b>\$ -</b>

**City of Atwater**  
Fiscal Year 2025-26 Budget

**SANITATION ENTERPRISE FUND**

**Overview**

Under the direction of the Public Works Director, to assure the efficient and safe daily refuse collection by independent contractor consistent with the policies and priorities established by the City Council.

**Objectives**

- To facilitate removal of rubbish and refuse from all business and homes.
- To provide semi-annual pickup of unwanted appliances and other items at central locations.
- To provide citizen participation in regional Household Hazardous Waste collection efforts.
- Provides for ongoing monitoring, regulatory compliance, and potential remediation activities for the former land fill located on Bert Crane Road.
- To ensure local compliance with state mandated waste reduction regulations.

**Revenues:**

Account Number	Description	FY 2023-24 Unaudited	FY 2024-25 Amended Budget as of 3/24/25	FY 2025-26 BUDGET
6020-0000-1051	Franchise Fees	\$ 6,037	\$ 4,000	\$ 4,700
6020-0000-4055	Refuse Service Charges	\$ 3,710,034	\$ 4,077,000	\$ 4,321,800
6020-0000-6001	Interest Earned	\$ 69,336	\$ 1,000	\$ 2,000
6020-0000-6091	Other Revenue	\$ 89,452	\$ -	\$ 1,000
6020-0000-4160	Contract Admin Fee	\$ 462,441	\$ 420,000	\$ 501,600
6020-0000-4161	Contract Fee - Admin & AB 939	\$ 198,189	\$ 204,000	\$ 216,942
	<b>Total Revenues</b>	<b>\$ 4,535,489</b>	<b>\$ 4,706,000</b>	<b>\$ 5,048,042</b>

# City of Atwater

## Fiscal Year 2025-26 Budget

### SANITATION ENTERPRISE FUND

#### Expenses:

Account Number	Description	FY 2023-24 Unaudited	FY 2024-25 Amended Budget as of 3/24/25	FY 2025-26 BUDGET	FY 2025-26 Details
6020-5059-1001	Salaries & Wages, Regular	\$ -			
6020-5059-1002	Salaries & Wages, Parttime	\$ -			
6020-5059-1003	Leave Accrual Buy-Out	\$ -			
6020-5059-1004	Overtime	\$ -	\$ 1,500	\$ 1,500	
6020-5059-1008	In-Lieu Of Insurance Benefit	\$ -			
6020-5059-1012	Fica/Medicare	\$ -			
6020-5059-1013	Retirement	\$ -			
6020-5059-1014	Health Insurance	\$ -			
6020-5059-1015	Worker's Compensation	\$ -			
6020-5059-2020	Office Supplies	\$ 20,857	\$ 18,000	\$ 23,000	
	Postage for Utility Billing (1/3 ea. Water/Sewer/Garbage)				
6020-5059-2021	Special Departmental Expense	\$ 16,490	\$ 87,000	\$ 87,350	
	Supplies				\$ 1,050
	Merced County Regional Waste				\$ 6,300
	Compost for SB1383 Compliance				\$ 80,000
6020-5059-2024	Uniform & Clothing Expense		\$ -		
6020-5059-3001	City Administration Fees - Incl. Internal Service Operations & Salary Alloc.	\$ 927,615	\$ 1,027,459	\$ 949,280	
6020-5059-3016	Solid Waste Collectn/Disposal	\$ 4,424,249	\$ 3,500,000	\$ 3,630,000	
6020-5059-3030	Professional Services	\$ 126,641	\$ 194,500	\$ 227,000	
	Printing and Mailing Utility Billing (1/3 ea. Water/Sewer/Garbage)				\$ 13,000
	Attorney Legal Services				\$ 25,000
	Recyclable Processing Fees				\$ 189,000
6020-5059-3031	Communications	\$ -	\$ -		
	Radio Announcements				
6020-5059-3036	Memberships & Subscriptions	\$ 253	\$ 2,455	\$ 2,580	
	Springbrook CivicPay Subscription-Utility Phone Payments				\$ 2,160
	Miscellaneous				\$ 420
6020-5059-3037	Travel/Conferences/Meetings	\$ -	\$ 850	\$ 900	
	Recertification, Electrical Courses, Etc.				\$ 375
	League of CA Cities-Public Works				\$ 525
6020-5059-3038	Training	\$ -	\$ 2,170	\$ 2,295	
	Recertification, Electrical Courses, Etc.				\$ 1,770
	League of CA Cities-Public Works				\$ 525
6020-5059-3090	Depreciation Expense	\$ 14,053	\$ -		
6020-5059-3096	Bad Debt Expense	\$ (9,129)	\$ -		
6020-5059-3102	Electronic Pmt Processing Exp	\$ 32,660	\$ 30,950	\$ 33,000	
	Utility Web Payment-Bluefin				
	Utility Bill Pay - Vanco				
	Utility Phone Payment - Springbrook				
6020-5059-4041	Equipment Maint. Charges	\$ 14,662	\$ 14,710	\$ 14,497	
6020-5059-4045	Building Maint. Charges	\$ 32,462	\$ 29,972	\$ 28,560	
6020-5059-4087	Information Technology Charges			\$ 15,837	
6020-5059-4088	Risk Management Charges	\$ 132	\$ -	\$ -	
6020-5059-4089	Employee Benefits Charges	\$ 4,072	\$ 4,581	\$ 5,357	
6020-5059-5030	Interest-Interfund Loans		\$ -		
6020-5059-6021	Machinery & Equipment	\$ -	\$ 10,000		
	Miscellaneous				
	<b>Total Expenditures</b>	<b>\$ 5,605,017</b>	<b>\$ 4,924,147</b>	<b>\$ 5,021,155</b>	

City of Atwater  
Fiscal Year 2025-26 Budget

**INTERNAL SERVICES FUND - CITY BUILDINGS AND  
EQUIPMENT MAINTENANCE**

**Overview – City Buildings**

Under the direction of the Public Works Director, to ensure that all City buildings are maintained in a safe and clean manner, not only for the employees to work, but for the general public.

**Objectives**

- To provide high level maintenance of the City's owned and operated buildings.
- To provide high level cleaning services to all City buildings.
- To perform repairs to protect the safety of employees, the general public and the City's investment.

**Revenues:**

Account Number	Description	FY 2023-24 Unaudited	FY 2024-25 Amended Budget as of 3/24/25	FY 2025-26 BUDGET
7000-0000-3023	MUHSD/AESD Reimbursement	\$ -	\$ -	\$ -
7000-0000-4081	Building Maintenance Charges	\$ 1,008,586	\$ 931,222	\$ 887,329
7000-0000-4082	Equipment Maintenance Charges	\$ 1,006,474	\$ 1,008,664	\$ 1,007,675
7000-0000-6001	Interest Earned	\$ 19,248	\$ -	\$ 2,000
7000-0000-6091	Other Revenue	\$ 35,935	\$ -	\$ -
	<b>Total Revenues</b>	<b>\$ 2,070,243</b>	<b>\$ 1,939,886</b>	<b>\$ 1,897,004</b>

**City of Atwater**  
**Fiscal Year 2025-26 Budget**

**INTERNAL SERVICES FUND – CITY BUILDINGS**

**Expenses:**

Account Number	Description	FY 2023-24 Unaudited	FY 2024-25 Amended Budget as of 3/24/25	FY 2025-26 BUDGET	FY 2025-26 Details
7000-1080-3090	Depreciation Expense	\$ 4	\$ -		
7000-9090-1001	Salaries & Wages, Regular	\$ 51,710	\$ 50,576	\$ 84,110	
	Bldg Maintenance Worker I				\$ 48,168
	Bldg Maintenance Worker I				\$ 35,942
7000-9090-1002	Salaries & Wages, Parttime	\$ 27,309	\$ 28,901		
	Bldg Maintenance Worker I				
7000-9090-1004	Overtime	\$ 256	\$ 3,000	\$ 3,000	
7000-9090-1008	In-Lieu Of Insurance Benefit		\$ -		
7000-9090-1012	Fica/Medicare	\$ 5,443	\$ 6,309	\$ 6,664	
7000-9090-1013	Retirement	\$ 32,705	\$ 30,881	\$ 36,254	
7000-9090-1014	Health Insurance	\$ 30,903	\$ 28,054	\$ 69,003	
7000-9090-1015	Worker's Compensation	\$ 6,239	\$ 6,110	\$ 6,428	
7000-9090-2021	Special Departmental Expense	\$ 87,889	\$ 114,300	\$ 104,300	
	HVAC Repair & Maintenance Parts (see 3030)				\$ 5,000
	Hepatitis & Flu Immunizations				\$ 500
	Hazardous Material Storage Permit (Corp Yard)				\$ 2,000
	Miscellaneous Building Repair and Maintenance Supplies				\$ 20,000
	Security Cameras (Corp Yard)				
	Keys & Locks				\$ 500
	Paper Products and Hand Soap				\$ 15,000
	Cleaning Products				\$ 5,000
	Paint for buildings				\$ 10,000
	Trash Bags				\$ 3,000
	Miscellaneous Janitorial Supplies				\$ 30,000
	Replace Bulbs, Ballasts and Lighting Fixtures				\$ 3,800
	Painting Supplies				\$ 1,500
	Parts and Supplies for Minor Electrical Repairs				\$ 8,000
7000-9090-2023	Small Tools	\$ 296	\$ 3,500	\$ 3,500	
	Mower/Weed eater				\$ 3,500
7000-9090-2024	Uniform & Clothing Expense	\$ 1,119	\$ 3,400	\$ 3,400	
	Uniform Cleaning Services				\$ 1,800
	Safety Boots				\$ 800
	Miscellaneous Safety Supplies				\$ 500
	PPE				\$ 300

**City of Atwater**  
**Fiscal Year 2025-26 Budget**

**INTERNAL SERVICES FUND – CITY BUILDINGS (cont.)**

**Expenses:**

Account Number	Description	FY 2023-24 Unaudited	FY 2024-25 Amended Budget as of 3/24/25	FY 2025-26 BUDGET	FY 2025-26 Details
7000-9090-3030	Professional Services	\$ 267,882	\$ 314,000	\$ 344,000	
	Contract Janitorial Services				\$ 190,000
	Miscellaneous Cleaning of Floors				\$ 1,000
	Miscellaneous Plumbing Repairs				\$ 2,500
	Fire Extinguisher and Stove Hood Repair Maintenance				\$ 12,000
	Fire/Security Alarm Repair and Maintenance				\$ 3,000
	HVAC Repair & Maintenance Parts				\$ 50,000
	Lock and Door Repair & Maintenance				\$ 2,000
	Building Maintenance				\$ 70,000
	Pest and Rodent Control				\$ 4,000
	Ice Machine and Refrigerator Repair				\$ 2,000
	Roll-Up Door Service and Repair				\$ 2,500
	Hazardous Materials Management				\$ 2,000
	Miscellaneous Electrical Repairs				\$ 3,000
7000-9090-3031	Communications	\$ 16,629	\$ 15,000	\$ 25,000	
	Telephone Services (AT&T, Verizon, Comcast)				
7000-9090-3032	Utilities	\$ 155,342	\$ 205,000	\$ 162,750	
	Gas Service at Veterans Park				\$ 3,150
	Propane at Corp Yard and Fire Stations				\$ 7,350
	Solar Power for City Hall & Community Center				\$ 57,750
	PG&E for City Buildings				\$ 94,500
7000-9090-3034	Rents & Leases	\$ -	\$ 600	\$ 600	
	Rental of Specialized Cleaning Equipment				
7000-9090-3035	Operations & Maintenance	\$ 1,041	\$ 6,000	\$ 6,000	
	Supplies and Equipment for Minor In-House Building Repairs				
7000-9090-3090	Depreciation Expense	\$ 34,260	\$ -		
7000-9090-4087	Information Technology Charges				
7000-9090-4088	Risk Management Charges	\$ 13,460	\$ 18,619	\$ 23,873	
7000-9090-4089	Employee Benefits Charges	\$ 6,278	\$ 6,972	\$ 8,447	
7000-9090-6021	Machinery & Equipment	\$ -	\$ -		
7000-9090-6031	Improvements Other Than Bldg	\$ 148,225	\$ 140,000		
	Station 42 Roof Repairs				
	Bloss Mansion Roof Repairs				
	<b>Total Expenditures</b>	<b>\$ 886,990</b>	<b>\$ 981,222</b>	<b>\$ 887,329</b>	

City of Atwater  
Fiscal Year 2025-26 Budget

**INTERNAL SERVICES FUND – EQUIPMENT MAINTENANCE AND  
EQUIPMENT REPLACEMENT FUND**

**Overview – Equipment Maintenance**

Under the direction of the Public Works Director, this department maintains City vehicles and equipment to assure a safe and productive operating status; continue a timely preventative maintenance program in order to promote and enhance equipment usefulness.

**Objectives**

- To provide high level of maintenance to the City's owned and operated vehicles and maintenance.
- To perform repairs and preventative maintenance on City owned and operated vehicles and equipment. To protect the safety of employees and the general public.

**Overview – Equipment Replacement Fund**

The Equipment Replacement Fund was established in Fiscal Year 2021/22 to begin the set-aside of funds for the future replacement of equipment that has past its estimated useful life.

City of Atwater  
Fiscal Year 2025-26 Budget

**INTERNAL SERVICE FUND – EQUIPMENT MAINTENANCE**

**Expenses:**

Account Number	Description	FY 2023-24 Unaudited	FY 2024-25 Amended Budget as of 3/24/25	FY 2025-26 BUDGET	FY 2025-26 Details
7000-9091-1001	Salaries & Wages, Regular	\$ 114,401	\$ 120,121	\$ 114,401	
	Mechanic II				\$ 60,501
	Mechanic I				\$ 53,900
7000-9091-1003	Leave Accrual Buy-Out		\$ -		
7000-9091-1004	Overtime	\$ 1,625	\$ 5,000	\$ 5,000	
7000-9091-1008	In-Lieu Of Insurance Benefit	\$ 7,200	\$ 7,200	\$ 7,200	
7000-9091-1012	Fica/Medicare	\$ 8,847	\$ 10,123	\$ 9,685	
7000-9091-1013	Retirement	\$ 43,888	\$ 38,908	\$ 37,711	
7000-9091-1014	Health Insurance	\$ 14,788	\$ 18,995	\$ 20,642	
7000-9091-1015	Worker's Compensation	\$ 9,443	\$ 9,803	\$ 9,342	
7000-9091-2020	Office Supplies	\$ -	\$ 800	\$ 800	
7000-9091-2021	Special Departmental Expense	\$ 4,510	\$ 5,000	\$ 5,000	
7000-9091-2023	Small Tools	\$ 3,486	\$ 5,000	\$ 5,000	
7000-9091-2024	Uniform & Clothing Expense	\$ 921	\$ 2,600	\$ 2,600	
	Uniform Service				\$ 2,000
	Boots				\$ 600
7000-9091-3030	Professional Services	\$ 127,722	\$ 180,000	\$ 180,000	
7000-9091-3031	Communications	\$ 527	\$ 1,300	\$ 1,300	
	Cell Phone				
7000-9091-3035	Operations & Maintenance	\$ 597,488	\$ 550,000	\$ 577,500	
	Fuel				\$ 357,000
	Parts, Materials, etc. for all City Vehicles				\$ 220,500
7000-9091-3038	Training	\$ -	\$ 2,000	\$ 2,000	
7000-9091-3090	Depreciation Expense	\$ 45,111	\$ -		
7000-9091-4087	Information Technology Charges	\$ 8,246	\$ 8,065	\$ 7,919	
7000-9091-4088	Risk Management Charges	\$ 18,591	\$ 25,436	\$ 23,701	
7000-9091-4089	Employee Benefits Charges	\$ 8,671	\$ 9,524	\$ 8,386	
7000-9091-6021	Machinery & Equipment	\$ -	\$ 15,000		
	New Car Lift				
	<b>Total Expenditures</b>	<b>\$ 1,015,465</b>	<b>\$ 1,014,875</b>	<b>\$ 1,018,187</b>	
	<b>Total Internal Service Fund - City Buildings and Equip Maint Expenditures</b>	<b>\$ 1,902,455</b>	<b>\$ 1,996,097</b>	<b>\$ 1,905,516</b>	

City of Atwater  
Fiscal Year 2025-26 Budget

**INTERNAL SERVICE FUND – EQUIPMENT/BUILDING REPLACEMENT**

**Revenues/Expenses:**

Account Number	Description	FY 2023-24 Unaudited	FY 2024-25 Amended Budget as of 3/24/25	FY 2025-26 BUDGET
7001-0000-8001	Trans FR General Fund	\$ 100,000	\$ 100,000	\$ 100,000
7001-0000-6001	Interest Earned	\$ 5,849		\$ 500
	<b>Total Revenues</b>	<b>\$ 105,849</b>	<b>\$ 100,000</b>	<b>\$ 100,500</b>
7001-1050-6021	Machinery & Equipment	\$ 110,916	\$ -	
	New Switches throughout City Encumbered FY 22/23			
7001-1050-6031	Improvements Other Than Bldg	\$ -	\$ -	
	Castle Youth Center Upgrades			
	<b>Total Expenditures</b>	<b>\$ 110,916</b>	<b>\$ -</b>	<b>\$ -</b>

# City of Atwater

## Fiscal Year 2025-26 Budget

### **INTERNAL SERVICES FUNDS FOR EMPLOYEE BENEFITS, RISK MANAGEMENT AND INFORMATION TECHNOLOGY**

#### **Overview**

Under the direction of the City Manager to maintain internal services to plan and protect the City's long-term financial viability and budgetary structure in areas related to employee benefits, risk management and information technology.

Employee benefits and risk management daily functions are managed by the Human Resources Department. For more information, please see the Human Resources Department narrative.

Information Technology (IT) provides information services to all City departments and ensures high operational efficiency with the minimization of service interruptions through the thoughtful application of technology solutions to enable the City to deliver innovative and sustained high-quality public services. Information services include support, planning, security, implementation, and maintenance of the City's technology infrastructure.

#### **Objectives**

- To provide current and long-range planning and management of employee related benefits
- To provide current and long-range planning and management of risk management activities
- To enhance staff capabilities with modern technologies and services
- To improve the City's information security posture through holistic security planning and implementation of industry-recognized best practices
- To utilize IT automation techniques to reduce support requirements
- To apply innovative and reasonably frugal solutions to the City's IT challenges
- To provide prudent and data-driven strategic and long-range IT planning
- To deliver a high rate of system reliability, stability, and availability
- To maximize the effectiveness of City public communication through technology

City of Atwater  
Fiscal Year 2025-26 Budget

**EMPLOYEE BENEFITS FUND**

**Revenues and Expenses:**

Account Number	Description	FY 2023-24 Unaudited	FY 2024-25 Amended Budget as of 3/24/25	FY 2025-26 BUDGET
7010-0000-4089	Employee Benefits Charges	\$ 767,380	\$ 851,597	\$ 948,700
7010-0000-6001	Interest Earned	\$ 19,323	\$ 3,500	\$ 3,500
7010-0000-6088	Health Reimbursements	\$ 61,952	\$ 48,000	\$ 48,000
	Dental and Vision Retiree Reimb			
	Dental Cost-Sharing (Actives)			
	Vision Cost-Sharing (Actives)			
	Life Insurance Cost-Sharing (Actives)			
	Short Term Disability Cost-Sharing (Actives)			
7010-0000-6091	Other Revenue		\$ -	\$ -
7010-0000-8001	Trn Fr General Fund	\$ 200,000	\$ 100,000	\$ 100,000
	Reserve for OPEB Obligations			
	Reserve for Pension Obligations			
	<b>Total Revenues</b>	<b>\$ 1,048,655</b>	<b>\$ 1,003,097</b>	<b>\$ 1,100,200</b>
7010-1010-3030	Professional Services	\$ 5,250	\$ 25,000	25000
	Legal Services			
	Actuarial Consulting Services			
7010-1050-3040	General Administration-Ins	\$ 4,070	\$ 3,200	\$ 3,200
	CalPERS (Active Admin Fee)			
7010-1050-3043	Health Insurance, Retirees	\$ 611,746	\$ 600,000	\$ 700,000
	Retiree Medical Reimbursements			
	CalPERS (Retiree Medical)			
	CalPERS (Retiree Admin Fee)			
7010-1050-3046	Unemployment Insurance	\$ 32,783	\$ 30,000	\$ 25,000
7010-1050-3047	Dental Insurance	\$ 139,053	\$ 150,000	\$ 100,000
7010-1050-3048	Vision Insurance	\$ 24,312	\$ 30,000	\$ 30,000
7010-1050-3049	Life Insurance	\$ 20,125	\$ 25,000	\$ 25,000
7010-1050-3050	Disability Insurance	\$ 49,617	\$ 40,000	\$ 50,000
7010-1050-9071	OPEB Expenses	\$ 100,000	\$ 50,000	\$ 50,000
	Reserve for OPEB Obligations			
7010-9095-9112	Transf To Pension Rate Stblztn	\$ 100,000	\$ 50,000	\$ 50,000
	<b>Total Expenditures</b>	<b>\$ 1,086,956</b>	<b>\$ 1,003,200</b>	<b>\$ 1,058,200</b>

City of Atwater  
Fiscal Year 2025-26 Budget

**RISK MANAGEMENT FUND**

**Revenues and Expenses:**

Account Number	Description	FY 2023-24 Unaudited	FY 2024-25 Amended Budget as of 3/24/25	FY 2025-26 BUDGET
7020-0000-4083	Worker's Compensation Charges	\$ 582,936	\$ 669,256	697,812
7020-0000-4088	Risk Management Charges	\$ 1,342,175	\$ 1,851,602	1,873,594
7020-0000-6001	Interest Earned	\$ 10,782	\$ 1,000	1,000
7020-0000-6091	Other Revenue	\$ 563,652	\$ 20,000	
	<b>Total Revenues</b>	<b>\$ 2,499,545</b>	<b>\$ 2,541,858</b>	<b>2,572,406</b>
7020-1050-1015	Worker's Compensation	\$ 582,936	\$ 668,502	697,812
7020-1050-2021	Special Departmental Expense	\$ 395	\$ 500	500
	State and Federal Labor Law Posters			
	Employment Law Resources			
	Losses below Deductible			
7020-1050-3030	Professional Services	\$ 87,144	\$ 150,000	150,000
	Risk Assessments/Liability Assmts			
	Special Counsel (ERMA)			
	Special Counsel (Litigation)			
	Attorney Legal Services			
7020-1050-3040	General Administration-Ins	\$ 5,729	\$ 6,902	8,786
7020-1050-3044	Liability & Property Ins	\$ 999,136	\$ 1,617,507	1,620,533
	CSJVRMA Liability Program			
	CSJVRMA Property Program			
	CSJVRMA Auto Physical Program			
	CSJVRMA Crime Shield Program			
7020-1050-3051	Employee Assistance Program	\$ 2,245	\$ 2,503	2,477
7020-1050-3053	Claim Payments/Settlements	\$ 842,972	\$ -	
7020-1050-3054	Employment Risk Management	\$ 70,658	\$ 74,190	91,298
7020-1050-3090	Depreciation Expense	\$ 3,142	\$ -	
	<b>Total Expenditures</b>	<b>\$ 2,594,357</b>	<b>\$ 2,520,104</b>	<b>\$ 2,571,406</b>

City of Atwater  
Fiscal Year 2025-26 Budget

**INFORMATION TECHNOLOGY FUND**

**Revenues and Expenses:**

Account Number	Description	FY 2023-24 Unaudited	FY 2024-25 Amended Budget as of 3/24/25	FY 2025-26 BUDGET	FY 2025-26 Details
7030-0000-3012	SJVAPCD Grant	\$ -	\$ -		
7030-0000-4087	Information Technology Charges	\$ 799,865	\$ 782,318	\$ 878,975	
7030-0000-6001	Interest Earned	\$ 14,994	\$ -	\$ 2,000	
	<b>Total Revenues</b>	<b>\$ 814,859</b>	<b>\$ 782,318</b>	<b>\$ 880,975</b>	
7030-1010-1001	Salaries & Wages, Regular	\$ 59,798	\$ 58,680	\$ 61,614	
	IT Systems Technician				\$ 61,614
7030-1010-1003	Leave Accrual Buy-Out		\$ -		
7030-1010-1004	Overtime	\$ 549	\$ 5,000	\$ 5,000	
7030-1010-1008	In-Lieu Of Insurance Benefit		\$ -		
7030-1010-1012	Fica/Medicare	\$ 4,198	\$ 4,872	\$ 5,096	
7030-1010-1013	Retirement	\$ 21,461	\$ 19,007	\$ 20,310	
7030-1010-1014	Health Insurance	\$ 7,394	\$ 9,498	\$ 10,321	
7030-1010-1015	Worker's Compensation	\$ 4,774	\$ 4,718	\$ 4,916	
7030-1050-2021	Special Departmental Expense	\$ 75,916	\$ 135,800	\$ 140,800	
	Computer Supplies				\$ 25,000
	Software				\$ 35,000
	Internet Services Civic Center #2				\$ 1,800
	Parner Data Dashboard				\$ 15,000
	Workstations				\$ 50,000
	Server Hardware/Software				\$ 5,000
	Audio/Video Equipment				\$ 9,000
7030-1050-3030	Professional Services	\$ 172,909	\$ 203,000	\$ 273,950	
	IT Services				\$ 100,000
	Network Security				\$ 10,500
	Document Management System				\$ 60,000
	Springbrook Annual Maintenance				\$ 93,450
	Springbrook payment/budget products				\$ 10,000
7030-1050-3031	Communications	\$ 126,805	\$ 159,000	\$ 166,900	
	City Wide Phone System (NHC)				\$ 50,400
	City-Wide Internet Service (AireSpring)				\$ 115,500
	Cell Phone				\$ 1,000
7030-1050-3036	Memberships & Subscriptions	\$ 106,806	\$ 145,414	\$ 152,686	
	MISAC				\$ 185
	Amazon Prime				\$ 2,100
	Acrobat Pro				\$ 3,150
	Access Control Hosting				\$ 1,365
	Broadcasting				\$ 4,200
	Website Hosting				\$ 31,500
	Cloud Storage of Servers				\$ 50,400
	NEOGOV				\$ 14,636
	CivicPlus				\$ 8,400
	System Management				\$ 36,750
7030-1050-3037	Travel/Conferences/Meetings	\$ -	\$ 500	\$ 500	
7030-1050-3038	Training	\$ -	\$ 1,300	\$ 1,300	
	Certification				\$ 800
	PluralSight				\$ 500
7030-1050-3090	Depreciation Expense	\$ 8,972	\$ -		
7030-1050-4045	Building Maint. Charges	\$ 1,595	\$ 1,473	\$ 1,403	
7030-1050-4088	Risk Management Charges	\$ 9,190	\$ 12,318	\$ 12,463	
7030-1050-4089	Employee Benefits Charges	\$ 1,681	\$ 1,737	\$ 1,716	
7030-1050-6021	Machinery & Equipment	\$ -	\$ 20,000	\$ 20,000	
	Hardware Replacement				\$ 20,000
	<b>Total Expenditures</b>	<b>\$ 602,048</b>	<b>\$ 782,317</b>	<b>\$ 878,975</b>	

**City of Atwater**  
Fiscal Year 2025-26 Budget

**SUCCESSOR AGENCY TO THE ATWATER REDEVELOPMENT  
AGENCY**

**Overview**

Pursuant to State Law the Atwater Redevelopment Agency was dissolved on February 1, 2012. The City of Atwater elected to be the Successor Agency. The City also elected to be the Housing Successor Agency. The purpose of the successor is to wind down the operations and to primarily complete legitimate projects and pay the outstanding debts - obligations of the former agency.

The primary expenses that are incurred are administrative, legal, and bond – debt expenses. The Successor prepares a Recognized Obligation Payment Schedule (ROPS) twice a year to request sufficient funds to cover the expense of the former agency. The ROPS are prepared and submitted to the County and State which review them and certify the request. Funds are then sent locally to cover the eligible expenses.

The Successor Agency also provides support to the Oversight Board. The Board was setup by law to ensure the Successor Agency is acting to dissolve the assets and pay the obligations for the former Agency.

**Redevelopment Obligation Retirement Fund (RORF)**

**Revenues and Expenses:**

Account Number	Description	FY 2023-24 Unaudited	FY 2024-25 Amended Budget as of 3/24/25	FY 2025-26 BUDGET
3064-0000-1118	ROPS Payments	\$ 1,067,725	\$ 1,115,159	\$ 1,070,793
3064-0000-6001	Interest Earned	\$ 31,533	\$ 1,500	\$ 10,000
3064-0000-8052	Trnsf Fr CommRdvlpmtPropTrust	\$ 190,023	\$ 12,081	\$ 13,091
	<b>Total Revenues</b>	<b>\$ 1,289,281</b>	<b>\$ 1,128,740</b>	<b>\$ 1,093,884</b>
3064-4016-3001	City Administration Fees	\$ 29,422	\$ 29,422	\$ 29,422
3064-4016-3030	Professional Services	\$ 22,657	\$ 50,500	\$ 45,000
3064-4016-3034	Rents & Leases	\$ -	\$ 2,000	\$ 2,000
3064-4016-3067	SERAF		\$ -	
3064-9095-9106	Transf to S.A. Debt Service	\$ 1,031,852	\$ 1,030,187	\$ 1,030,929
3064-9095-9110	Transf To CommRdvlpmtPropTrust		\$ -	
	<b>Total Expenditures</b>	<b>\$ 1,083,931</b>	<b>\$ 1,112,109</b>	<b>\$ 1,107,351</b>

**City of Atwater**  
Fiscal Year 2025-26 Budget

**Low & Mod Income Housing Asset Fund**

**Revenues and Expenses:**

<b>Account Number</b>	<b>Description</b>	<b>FY 2023-24 Unaudited</b>	<b>FY 2024-25 Amended Budget as of 3/24/25</b>	<b>FY 2025-26 BUDGET</b>
3065-0000-6001	Interest Earned	\$ 31,367	\$ 3,000	\$ 10,000
3065-0000-6022	Sale of Real Property	\$ 80,000	\$ -	
3065-0000-6091	Other Revenue	\$ 1,000	\$ 1,000	
3065-0000-8053	Trnsf Fr RdvlpmtOblgRtrmntFund		\$ -	
	<b>Total Revenues</b>	<b>\$ 112,367</b>	<b>\$ 4,000</b>	<b>\$ 10,000</b>
3065-4017-3030	Professional Services	\$ 1,988	\$ 20,000	\$ 20,000
3065-9095-9050	Trn To General Fund	\$ 50,000	\$ 50,000	
	Muni Code Update			
	<b>Total Expenditures</b>	<b>\$ 51,988</b>	<b>\$ 70,000</b>	<b>\$ 20,000</b>

**Successor Agency Debt Service Fund**

**Revenues and Expenses:**

<b>Account Number</b>	<b>Description</b>	<b>FY 2023-24 Unaudited</b>	<b>FY 2024-25 Amended Budget as of 3/24/25</b>	<b>FY 2025-26 BUDGET</b>
3066-0000-8053	Trnsf Fr RdvlpmtOblgRtrmntFund	\$ 1,031,852	\$ 1,030,187	\$ 1,030,929
	<b>Total Revenues</b>	<b>\$ 1,031,852</b>	<b>\$ 1,030,187</b>	<b>\$ 1,030,929</b>
3066-8020-5010	Principal-ARA Bond	\$ 993,926	\$ 979,000	\$ 1,005,000
3066-8020-5020	Interest-ARA Bond	\$ 75,852	\$ 51,187	\$ 25,929
	<b>Total Expenditures</b>	<b>\$ 1,069,778</b>	<b>\$ 1,030,187</b>	<b>\$ 1,030,929</b>

**Community Redevelopment Prop Trust**

**Revenues and Expenses:**

<b>Account Number</b>	<b>Description</b>	<b>FY 2023-24 Unaudited</b>	<b>FY 2024-25 Amended Budget as of 3/24/25</b>	<b>FY 2025-26 BUDGET</b>
3067-0000-4072	Project Extension Fees	\$ 1,584	\$ 1,584	\$ 1,584
3067-0000-4074	Applegate Connection Fees		\$ -	
3067-0000-6001	Interest Earned	\$ 4,014	\$ 400	\$ 100
3067-0000-6022	Sale of Real Property	\$ 36,914	\$ 10,414	
3067-0000-6023	Sw Quad Storm Drainage Fees	\$ -	\$ -	
3067-0000-8053	Trnsf Fr RdvlpmtOblgRtrmntFund	\$ -	\$ -	
	<b>Total Revenues</b>	<b>\$ 42,512</b>	<b>\$ 12,398</b>	<b>\$ 1,684</b>
3067-9095-9107	Transfer To RORF	\$ 190,023	\$ 12,081	\$ 13,091
	<b>Total Expenditures</b>	<b>\$ 190,023</b>	<b>\$ 12,081</b>	<b>\$ 13,091</b>

# Five Year Capital Improvement Program

Fiscal Years 2025-26 through 2029-30

### CAPITAL IMPROVEMENT PROGRAM

DESCRIPTION	2025/26	2026/27	2027/28	2028/29	2029/30	FUNDING SOURCE
<b>General Fund Capital (0003)</b>						
*Phase 2 Ped Imp Proj Downtown	1,079,237					0003 General Fund Capital - CMAQ
*Phase 3 Ped Imp Proj Downtown						0003 General Fund Capital - CMAQ
*Phase 4 Ped Imp Proj Downtown		3,156,621				0003 General Fund Capital - CMAQ
*City Wide Signal Synchronization	1,020,653					0003 General Fund Capital - CMAQ
<b>General Fund Capital (0003) Totals</b>	<b>2,099,890</b>	<b>3,156,621</b>				
<b>CRP (XXXX) NEED TO CREATE NEW FUND</b>						
*Phase 2 Ped Imp Proj Downtown	1,267,749					XXXX CRP (Carbon Reduction Program) Fund
<b>CRP (XXXX) Totals</b>	<b>1,267,749</b>					
<b>Measure V (0007)</b>						
*Fruitland Avenue Road Improvements	200,000					0007 Measure V
*City Wide Signal Synchronization	152,236					0007 Measure V
<b>Measure V (0007) Totals</b>	<b>152,236</b>					
<b>Measure V 20% Alternative Modes (0008)</b>						
*Active Transportation Plan						0008 Measure V Alternative Modes
*Phase 2 Ped Imp Proj Downtown	391,796					0008 Measure V Alternative Modes
*Phase 3 Ped Imp Proj Downtown						0008 Measure V Alternative Modes
*Phase 4 Ped Imp Proj Downtown		408,974				0008 Measure V Alternative Modes
<b>Measure V 20% Alternative Modes (0008) Totals</b>	<b>391,796</b>	<b>408,974</b>				
<b>Measure V Regional Funds (0010)</b>						
*Bellevue Road Realignment	2,150,000	5,542,000				0010 Measure V Regional Funds
*Buhach Widening	200,000					0010 Measure V Regional Funds
<b>Measure V Regional Funds (0010) Totals</b>	<b>2,350,000</b>	<b>5,542,000</b>				
<b>Local Transportation Fund (1013)</b>						
*Fruitland Avenue Road Improvements						1013 LTF Fund
*Olive Avenue Overlay	230,370					1013 LTF Fund
<b>Local Transportation Fund (1013) Totals</b>	<b>230,370</b>					

**CAPITAL IMPROVEMENT PROGRAM (continued)**

DESCRIPTION	2025/26	2026/27	2027/28	2028/29	2029/30	FUNDING SOURCE
<b>Traffic Circulation Fund (1015)</b>						
*Traffic Signal at Juniper Ave & Bridgewater St.	184,000					1015 Traffic Circulation Fund
Traffic Circulation Fund (1015) Totals	184,000					
<b>Regional Surface Transportation Program-RSTP (1017)</b>						
*Olive Avenue Overlay	200,000					1017 RSTP Fund
*Ace Train Platform					219,663	1017 RSTP Fund
Regional Surface Transportation Prog-RSTP (1017) Totals	200,000				219,663	
<b>SB1-Road Maintenance &amp; Rehab RMRA (1018)</b>						
Curb, Gutter, and Sidewalk Maintenance, Repair and Replacement	200,000					1018 SB1 Fund
Pavement Markings and Signage Maintenance	160,000					1018 SB1 Fund
Traffic Signals Maintenance and Repairs	20,000					1018 SB1 Fund
Pavement Repairs	192,583					1018 SB1 Fund
*Olive Avenue Overlay	100,000					1018 SB1 Fund
SB1-Road Maintenance & Rehab RMRA (1018) Totals	672,583					
<b>Parks &amp; Recreation (1020)</b>						
*Osborn Park Renovation	400,000	200,000				2018 Parks Bond Act, Per Capita Grant Program
Parks & Recreation (1020) Totals	400,000	200,000				
<b>Water Capital (6001)</b>						
Hydrant Replacement						6001 Water Capital Fund
*Well #20A Rehab						6001 Water Capital Fund
Installation-New Water Meters						6001 Water Capital Fund
*Property Acq.-Future Well Site		100,000				6001 Water Capital Fund
*Canal Creek Utility Crossing	250,000					6001 Water Capital Fund
Water Capital (6001) Totals	250,000	100,000				

**CAPITAL IMPROVEMENT PROGRAM (continued)**

DESCRIPTION	2025/26	2026/27	2027/28	2028/29	2029/30	FUNDING SOURCE
<b>Sewer (6010)</b>						
*Canal Creek Utility Crossing	250,000					6010 Sewer Fund
*Castle Sewer Interceptor	1,950,000					6010 Sewer Fund
*Lower Shaffer Storm Drain Imp	6,000,000					6010 Sewer Fund
*Atwater Blvd Drainage Improvements					4,000,000	6010 Sewer Fund
*Eucaluptus and First St Drainage Improvements						6010 Sewer Fund
<b>Sewer (6010) Totals</b>	<b>8,200,000</b>				<b>4,000,000</b>	
<b>Capital Improvement Projects Total</b>	<b>16,398,624</b>	<b>9,407,595</b>			<b>4,219,663</b>	

\* Major public works projects such as land, buildings, and public infrastructure. Must conform with the City's General Plan.

*End CIP*

Blank Page

# Debt Service

City of Atwater  
Fiscal Year 2024-25 Budget

**DEBT SERVICE OBLIGATIONS**

<b>Debt Service - Fiscal Year 2025-26</b>				
	<u>Date</u>	<u>Principal</u>	<u>Interest</u>	<u>Total</u>
<b><u>Wastewater Fund</u></b>				
<u>2017A Wastewater Bonds</u>				
	11/1/2025	-	1,068,044	1,068,044
	5/1/2026	<u>1,175,000</u>	<u>1,068,044</u>	<u>2,243,044</u>
Total		1,175,000	2,136,088	3,311,088
<u>2018A Wastewater Bonds</u>				
	11/1/2025	-	198,884	198,884
	5/1/2026	<u>740,000</u>	<u>198,884</u>	<u>938,884</u>
Total		740,000	397,769	1,137,769
	<u>Date</u>	<u>Principal</u>	<u>Interest</u>	<u>Total</u>
<b><u>Successor Agency to the Atwater RDA Bonds</u></b>				
<u>2017A Bonds</u>				
	12/1/2025	-	12,965	12,965
	6/1/2026	<u>1,005,000</u>	<u>12,965</u>	<u>1,017,965</u>
Total		1,005,000	25,929	1,030,929
<u>2017B Bonds</u>				
	12/1/2025	-	-	-
	6/1/2026	<u>-</u>	<u>-</u>	<u>-</u>
Total		-	-	-

# City of Atwater

## Fiscal Year 2024-25 Budget

### INTERFUND TRANSFERS

City of Atwater							
Interfund Transfers							
Fiscal Year 2025-26							
<u>From (Expenditure)</u>			<u>To (Revenue)</u>				
Fund Name	GL Account	Description	Fund Name	GL Account	Description	Amount	Purpose
General Fund	0001-9095-9069	Transf. to Maint District Funds	Maintenance Districts	5000-0000-8001	Transf. from General Fund	\$ 145,000	General Benefit Contribution to Maint Districts/Shortfall*
							General Benefit Contribution to Maint Districts
							Maintenance Districts (Shortfall)
General Fund	0001-9095-9084	Transf. to Emp. Benefits Fund	Emp. Benefits Fund	7010-0000-8001	Transf. from General Fund	\$ 100,000	Contrib to PARS - to help fund unfunded OPEB/Retirement
							Reserve for OPEB Obligations
							Reserve for Pension Obligations
General Fund	0001-9095-9111	Transf. to ISF Equip/BldgReplac	ISF Equip/Bldg Replac	7001-0000-8001	Transf. from General Fund	\$ 100,000	Contrib to ISF Equipment/Building Replacement Fund
General Fund	0001-9095-9057	Transf. to Gas Tax/Street Improv	Gas Tax Fund	1011-0000-8001	Transf. from General Fund	\$ 512,728	Contrib to Gas Tax Fund for Road Maint.
General Fund	0001-9095-XXXX	Transf. to CFD- Public Safety	CFD	5050-0000-XXXX	Transf. from General Fund	\$ 160,821	General Fund subsidy/Shortfall*
Water Fund	6000-9095-9050	Transf. to General Fund	General Fund	0001-0000-8005	Transf. from Water	\$ 152,375	Hydrant Maintenance
Employee Benefits Fund	7010-9095-9112	Transf. to Pension Rate Stblztn	Pension Rate Stblztn Fund	4080-0000-8060	Transf. from Emp. Benefits Fund	\$ 50,000	Contrib to PARS - to help fund unfunded OPEB/Retirement
<b>Successor Agency to the Atwater Redevelopment Agency</b>							
RDVLPMENT Obligation	3064-9095-9106	Transf. to S.A. Debt Service	SA Debt Service	3066-0000-8053	Transf. from RdlpmtOblgRtr	\$ 1,030,929	Debt Service
Community RDVLPMENT Prop Trust	3067-9095-9107	Transf. to RORF	RDVLPMENT OblgRtrmnt	3064-0000-8052	Transf. from CommRdlpmtPropTrust	\$ 13,091	From Community Redevelopment Prop Trust to RORF
					Total Transfers:	\$ 2,264,944	
<i>*Denotes a transfer amount based on estimate. The actual transfer amount may vary based on actual expenses throughout the year.</i>							

# Supplemental



**CITY COUNCIL  
OF THE  
CITY OF ATWATER**

**RESOLUTION NO. 3068-19**

**A RESOLUTION OF THE CITY COUNCIL OF THE CITY OF  
ATWATER APPROVING GENERAL FUND RESERVE  
POLICY AND INTER-FUND ADVANCE AND LOAN POLICY**

**WHEREAS**, the City of Atwater recognizes the importance of sound fiscal policies to ensure its future sustainability as a municipal agency; and

**WHEREAS**, the City seeks to comply with local, state and federal laws regulating the use of public funds; and

**WHEREAS**, the City is committed to restoring public trust in its ability to manage the public's funds; and

**WHEREAS**, the City is committed to adhering to best fiscal management practices as established by the Government Finance Officers Association and the State of California's Auditor; and

**WHEREAS**, on February 24, 2014, the City Council adopted Resolution No. 2478-14 establishing a General Fund Reserve Policy and Inter-Fund Advance and Loan Policy; and

**WHEREAS**, the General Fund Reserve Policy and an Inter-Fund Advance and Loan Policy must be reviewed and may be amended from time to time.

**NOW THEREFORE, BE IT RESOLVED** by the City Council of the City of Atwater that the General Fund Reserve Policy and Inter-Fund Advance and Loan Policy attached as "**Exhibit A**" are hereby approved.

**BE IT FURTHER RESOLVED** by the City Council of the City of Atwater that all previous resolutions establishing General Fund Reserve Policy and Inter-Fund Advance and Loan Policy is hereby superseded by Resolution No. 3068-19.

The foregoing resolution is hereby adopted this 25<sup>th</sup> day of March 2019.

AYES: Cale, Raymond, Ambriz, Creighton  
NOES: None  
ABSENT: Vierra

APPROVED:

  
\_\_\_\_\_  
PAUL CREIGHTON, MAYOR

ATTEST:

  
\_\_\_\_\_  
LUCY ARMSTRONG, CITY CLERK

## Exhibit A

### CITY OF ATWATER

#### GENERAL FUND RESERVE POLICY

The purpose of this policy is to ensure that the City will at all times have sufficient funding available to meet its operating, capital and debt service cost obligations. Reserves will be managed in a manner that allows the City to fund costs consistent with the operating and capital budgets as well as other long-term plans. While General Fund Reserves have been depleted during the recent economic downturn, it is the Policy of this City Council that General Fund Reserves be increased in an orderly manner, over time, through prudent fiscal management to a minimum target level of ten (10) percent of annual General Fund Operating costs. At the end of each fiscal year, the City Council will be provided a report indicating the status of General Fund Reserves in relation to the minimum target balance.

### CITY OF ATWATER

#### INTER-FUND ADVANCE AND LOAN POLICY

The City of Atwater uses fund accounting as required under generally accepted accounting principles for government agencies as promulgated by the Government Accounting Standards Board (GASB). Generally accepted accounting principles for government agencies permit and provide accounting conventions for loans and advances between funds of a local agency.

Unless otherwise prohibited by law or sound fiscal management practices, the City will from time to time enter into transactions requiring inter-fund movement of funds through fund advances and loans in accordance with the following policy:

1. INTER-FUND ADVANCE AND LOAN POLICY
  - a. Short-term advances or loans between City funds for short-term cash flow needs (expected to be repaid within ninety days after the end of the current fiscal year) must be approved in advance in writing by the City Manager.
  - b. Advances or loans between City funds which are not initially expected to extend beyond ninety days after the end of the current fiscal year, but which extend beyond this period must be approved by the City Council as soon as it is determined that the term of the loan or advance will extend beyond the fiscal year.

Any adjustment to the terms of a fund advance or loan which will result in the fund loan or advance extending beyond one year or which increases the repayment amount of the fund loan or advance must be approved, in advance, by the City Council.

## 2. DOCUMENTATION

- a. Each advance, excluding short-term, or loan approved by the City Manager or City Council will be documented in writing and will provide the following information:
  - i. The purpose for which the loan or advance is being made, and
  - ii. The identification of both the borrowing and lending fund or funds, and
  - iii. The dollar amount of the loan or advance, and
  - iv. The nominal interest rate (if applicable), and
  - v. The terms for repayment of the loan or advance including the dates for installment payments and maturity date on which all principal and unpaid interest will be due and payable, and
  - vi. The source from which the borrowing fund is expected to repay the loan/advance, and
  - vii. Demonstrated ability to repay the loan and any associated interest within the allotted loan period without causing a negative impact to the finances of the requesting or receiving party.
- b. All of the above conditions must be met in order to qualify for a loan or an advance. This policy applies to all City funds.
- c. The Finance Department will maintain a current listing of all inter-fund advances and loans.

## 3. REVIEW

- a. All outstanding inter-fund advances and loans will be reviewed by the City Manager at least annually to determine compliance with the agreed upon terms and the recoverability of the funds due. It is expected that all advances and loans will be repaid according to the established payment schedule. However, the City may repay advances and/or loans early or may elect to pay lump sums towards outstanding principal. In the event of a lump sum payment, a resolution amending the repayment schedule will be presented to the City Council for approval.
- b. In accordance with the provisions of generally accepted accounting principles (GAAP) any advance or loan which is not expected to be repaid within a reasonable time will be recorded in the City's financial records as a fund transfer.



**CITY COUNCIL  
OF THE  
CITY OF ATWATER**

**RESOLUTION NO. 3539-25**

**RESOLUTION OF THE CITY COUNCIL OF THE  
CITY OF ATWATER ESTABLISHING THE FISCAL  
YEAR 2025-26 APPROPRIATIONS LIMITATION**

**WHEREAS**, the people of California on November 6, 1979, added Article XIII B to the State Constitution placing various limitations on the appropriations of state and local governments; and

**WHEREAS**, the State Legislature adopted Chapters 1205 and 1342 of the 1980 Statutes which implemented Article XIII B; and

**WHEREAS**, the people of California on June 5, 1990 amended Article XIII B effective July 1, 1990; and

**WHEREAS**, the provisions of the amendments have been interpreted by a coalition of statewide organizations, and the organizations have issued through the League of California Cities revised guidelines to calculate the appropriations limitation (GANN Limit); and

**WHEREAS**, Section 7910 of the California Government Code requires cities to adopt a resolution setting the annual appropriations limitation (GANN Limit) at a regularly scheduled meeting or a noticed special meeting; and

**WHEREAS**, the City of Atwater has complied with the provisions of Article XIII B in calculating the Appropriations Limitation (GANN Limit) for Fiscal Year 2025-26.

**NOW, THEREFORE, BE IT RESOLVED** by the City Council of the City of Atwater that pursuant to the appropriations limitation formula set forth in California Government Code Sections 7900-7913, the City Council hereby establishes the appropriations limitation (GANN Limit) for the 2025-26 fiscal year for the City of Atwater at \$66,711,927 as documented in **Exhibit A**, attached hereto and incorporated here by reference.

**BE IT FURTHER RESOLVED** that any challenge to the appropriations limitation as per the above-mentioned codes must be brought to the City of Atwater's attention within sixty (60) days of the effective date of this resolution.

The foregoing resolution is hereby adopted this 9<sup>th</sup> day of June 2025.

**AYES:  
NOES:  
ABSENT:**

**APPROVED:**

\_\_\_\_\_  
**MIKE NELSON, MAYOR**

**ATTEST:**

\_\_\_\_\_  
**KORY J. BILLINGS, CITY CLERK**

**EXHIBIT "A"**

**APPROPRIATIONS LIMITATION**

The appropriations limitation imposed by Proposition 4 and amended by Proposition 111 creates a restriction on the amount of revenue which can be appropriated in any fiscal year. The revenues which are subject to the limitation are those considered "proceeds of taxes." The basis for calculating the limit began in 1978-79 and is increased each year based on population growth and inflation.

FY 2024-25 Limitation: \$62,775,879

**Annual Adjustment for Fiscal Year 2025-26 Calculations:**

Change in population	=	-0.18 percent
Change in per capita personal income	=	6.44 percent
Population Factor Converted to a Ratio	=	.9982
Per Capita Factor Converted to a Ratio	=	1.0647

Calculation of factor for FY 2025-26: .9982 x 1.0647 = **1.0627**

**Calculation of FY 2025-26 Appropriations Limitation:**

**\$62,775,879 X 1.0627 = \$66,711,927**

\*\*\*\*\*

FY 2025-26 Appropriations = \$ 85,169,612

**Less: Funds Not Subject to Limit**

Successor Agency to Atwater Redevelopment Agency	(\$1,030,929)
Water Enterprise Fund (Capital Outlay)	(\$2,425,000)
Wastewater Enterprise Fund	(\$8,451,000)
Sanitation Enterprise Fund	(\$5,021,293)
Capital Outlay (non-Enterprise Funds)	(\$9,573,061)

Less: Non-Tax Revenue (\$6,450,136)

**Appropriations Subject to Limitation \$52,218,193**



**CITY COUNCIL  
OF THE  
CITY OF ATWATER**

**RESOLUTION NO. XXXX-25**

**A RESOLUTION OF THE CITY COUNCIL OF THE  
CITY OF ATWATER AMENDING CITY OF  
ATWATER CLASSIFICATION PLAN AND  
ADOPTING SALARY SCHEDULE  
A-26 EFFECTIVE JUNE 19, 2025**

**WHEREAS**, the City Council adopted Resolution No. 2088-05 revising the City of Atwater Classification Plan; and

**WHEREAS**, Salary Schedule C-25, effective February 24, 2025, was adopted by Resolution No. 3519-25 on February 24, 2025; and

**WHEREAS**, the City Council approves and adopts a salary schedule for the Classification Plan and/or directs the City Manager to prepare and/or update said schedule to reflect City Council direction; and

**WHEREAS**, the salary schedule is being modified to implement contractual monetary obligations agreed upon in Memorandum of Understandings (MOUs), and to record classifications approved in the FY 2025-2026 budget; and

**NOW, THEREFORE, BE IT RESOLVED** that the City Council of the City of Atwater does hereby amend the salary schedule as shown in “**Exhibit A**,” and directs the City Manager to update the salary schedule as approved.

**BE IT FURTHER RESOLVED** that the City Manager is hereby authorized to make any revisions, corrections, or alterations to the text of the classifications described in “**Exhibit A**” to correct language changes, modify job descriptions, or to comply with the requirements of the law.

The foregoing resolution is hereby adopted this 9<sup>th</sup> day of June 2025.

**AYES:**

**NOES:**

**ABSENT:**

**APPROVED:**

\_\_\_\_\_  
**MIKE NELSON, MAYOR**

**ATTEST:**

\_\_\_\_\_  
**KORY J. BILLINGS, CITY CLERK**

# Exhibit A

**SALARY SCHEDULE BY MONTHLY/BI-WEEKLY/ANNUAL/HOURLY RATES PER STEP  
SCHEDULE A-26 EFFECTIVE JUNE 19, 2025**

	Class	Grade	Step 1	Step 2	Step 3	Step 4	Step 5	Step 6
Account Clerk I	CU	115	3051.01	3203.56	3363.73	3531.92	3708.52	3893.94
			1408.16	1478.56	1552.49	1630.12	1711.62	1797.20
			36612.08	38442.68	40364.81	42383.06	44502.21	46727.32
			17.6020	18.4821	19.4062	20.3765	21.3953	22.4651
Account Clerk II	CU	135	3417.90	3588.79	3768.23	3956.64	4154.48	4362.20
			1577.49	1656.37	1739.18	1826.14	1917.45	2013.32
			41014.77	43065.51	45218.79	47479.72	49853.71	52346.40
			19.7186	20.7046	21.7398	22.8268	23.9681	25.1665
Accountant I	CU	255	4481.51	4705.58	4940.86	5187.90	5447.30	5719.66
			2068.39	2171.81	2280.40	2394.42	2514.14	2639.84
			53778.07	56466.97	59290.32	62254.84	65367.58	68635.96
			25.8548	27.1476	28.5050	29.9302	31.4267	32.9981
Accountant II	CU	270	5001.59	5251.67	5514.25	5789.96	6079.46	6383.44
			2308.43	2423.85	2545.04	2672.29	2805.91	2946.20
			60019.07	63020.02	66171.02	69479.57	72953.55	76601.23
			28.8553	30.2981	31.8130	33.4036	35.0738	36.8275
Accounting Technician	CU	235	3977.60	4176.49	4385.31	4604.57	4834.80	5076.54
			1835.82	1927.61	2023.99	2125.19	2231.45	2343.02
			47731.26	50117.82	52623.71	55254.90	58017.64	60918.52
			22.9477	24.0951	25.2999	26.5649	27.8931	29.2878
Administrative Assistant I	CU	140a	3028.46	3179.88	3338.88	3505.82	3681.11	3865.17
			1397.75	1467.64	1541.02	1618.07	1698.97	1783.92
			36341.51	38158.59	40066.52	42069.84	44173.33	46382.00
			17.4719	18.3455	19.2627	20.2259	21.2372	22.2990
Administrative Assistant II	CU	155a	3460.16	3633.17	3814.83	4005.57	4205.85	4416.14
			1597.00	1676.85	1760.69	1848.73	1941.16	2038.22
			41521.96	43598.06	45777.96	48066.86	50470.20	52993.71
			19.9625	20.9606	22.0086	23.1091	24.2645	25.4777
Assistant City Clerk/Records Coordinator	MM	101	4948.38	5195.80	5455.59	5728.37	6014.79	6315.53
			2283.87	2398.06	2517.97	2643.86	2776.06	2914.86
			59380.59	62349.62	65467.10	68740.45	72177.48	75786.35
			28.5484	29.9758	31.4746	33.0483	34.7007	36.43575
Assistant Planner	MU	257	4578.67	4807.61	5047.99	5300.39	5565.41	5843.68
			2113.23	2218.90	2329.84	2446.33	2568.65	2697.08
			54944.07	57691.28	60575.84	63604.63	66784.86	70124.11
			26.4154	27.7362	29.1230	30.5792	32.1081	33.7135
Associate Planner	MU	275	4933.57	5180.25	5439.26	5711.23	5996.79	6296.63
			2277.03	2390.89	2510.43	2635.95	2767.75	2906.14
			59202.87	62163.02	65271.17	68534.73	71961.46	75559.54
			28.4629	29.8861	31.3804	32.9494	34.5969	36.3267
Building Maintenance Worker I	MU	130	2995.29	3145.06	3302.31	3467.43	3640.80	3822.84
			1382.44	1451.57	1524.14	1600.35	1680.37	1764.39
			35943.52	37740.70	39627.73	41609.12	43689.58	45874.06
			17.2805	18.1446	19.0518	20.0044	21.0046	22.0548
Building Maintenance Worker II	MU	150a	3199.54	3359.52	3527.49	3703.87	3889.06	4083.51
			1476.71	1550.55	1628.07	1709.48	1794.95	1884.70
			38394.47	40314.19	42329.90	44446.40	46668.72	49002.15
			18.4589	19.3818	20.3509	21.3685	22.4369	23.5587
Building Permit Technician I	MU	185	3597.62	3777.50	3966.38	4164.69	4372.93	4591.58
			1660.44	1743.46	1830.64	1922.17	2018.28	2119.19
			43171.44	45330.01	47596.51	49976.34	52475.16	55098.91
			20.7555	21.7933	22.8829	24.0271	25.2284	26.4899
Building Permit Technician II	MU	187	3966.38	4164.70	4372.94	4591.58	4821.16	5062.22
			1830.64	1922.17	2018.28	2119.19	2225.15	2336.41
			47596.60	49976.43	52475.25	55099.01	57853.96	60746.66
			22.8830	24.0271	25.2285	26.4899	27.8144	29.2051
Chief Building Official/Fire Code Official	MM	308a	8239.35	8651.32	9083.88	9538.08	10014.98	10515.73
			3802.78	3992.91	4192.56	4402.19	4622.30	4853.41
			98872.18	103815.78	109006.57	114456.90	120179.75	126188.74
			47.5347	49.9114	52.4070	55.0274	57.7787	60.6677
City Engineer	MM	117	8528.42	8954.84	9402.58	9872.71	10366.34	10884.66
			3936.19	4133.00	4339.65	4556.63	4784.47	5023.69
			102340.99	107458.04	112830.94	118472.49	124396.12	130615.92
			49.2024	51.6625	54.2456	56.9579	59.8058	62.7961

**SALARY SCHEDULE BY MONTHLY/BI-WEEKLY/ANNUAL/HOURLY RATES PER STEP  
SCHEDULE A-26 EFFECTIVE JUNE 19, 2025**

	Class	Grade	Step 1	Step 2	Step 3	Step 4	Step 5	Step 6
City Manager	EM	340	13673.71	14357.40	15075.27	15829.03	16620.48	17451.51
			6310.94	6626.49	6957.82	7305.71	7670.99	8054.54
			164084.54	172288.77	180903.21	189948.37	199445.79	209418.08
			78.8868	82.8311	86.9727	91.3213	95.8874	100.6818
Civil Engineering Assistant	MU	277	5034.76	5286.50	5550.83	5828.37	6119.79	6425.78
			2323.74	2439.92	2561.92	2690.02	2824.52	2965.74
			60417.18	63438.04	66609.94	69940.44	73437.46	77109.33
			29.0467	30.4991	32.0240	33.6252	35.3065	37.0718
Code Enforcement Manager	MM	299	5998.65	6298.58	6613.51	6944.18	7291.39	7655.96
			2768.61	2907.04	3052.39	3205.01	3365.26	3533.52
			71983.77	75582.95	79362.10	83330.21	87496.72	91871.55
			34.6076	36.3380	38.1549	40.0626	42.0657	44.1690
Code Enforcement Officer	MU	175	3853.63	4046.31	4248.62	4461.05	4684.11	4918.31
			1778.60	1867.53	1960.90	2058.95	2161.90	2269.99
			46243.52	48555.69	50983.48	53532.65	56209.28	59019.75
			22.2325	23.3441	24.5113	25.7369	27.0237	28.3749
Community Development Director	DD	337	10766.51	11304.83	11870.07	12463.58	13086.76	13741.09
			4969.16	5217.61	5478.50	5752.42	6040.04	6342.04
			129198.08	135657.98	142440.88	149562.92	157041.07	164893.12
			62.1145	65.2202	68.4812	71.9053	75.5005	79.2755
Community Services Officer	PU	160	3768.23	3956.64	4154.47	4362.19	4580.30	4809.32
			1739.18	1826.14	1917.45	2013.32	2113.99	2219.69
			45218.72	47479.66	49853.64	52346.32	54963.64	57711.82
			21.7398	22.8268	23.9681	25.1665	26.4248	27.7461
Executive Assistant	CU	183	3953.19	4150.84	4358.39	4576.31	4805.12	5045.38
			1824.55	1915.77	2011.56	2112.14	2217.75	2328.64
			47438.23	49810.14	52300.65	54915.68	57661.46	60544.53
			22.8068	23.9472	25.1445	26.4018	27.7219	29.1079
Finance Director	DD	335	9791.30	10280.86	10794.91	11334.65	11901.38	12496.45
			4519.06	4745.01	4982.26	5231.38	5492.95	5767.59
			117495.58	123370.36	129538.88	136015.82	142816.61	149957.44
			56.4883	59.3127	62.2783	65.3922	68.6618	72.0949
Finance Operations Manager	MM	307	6285.83	6600.12	6930.13	7276.64	7640.47	8022.49
			2901.15	3046.21	3198.52	3358.45	3526.37	3702.69
			75429.99	79201.49	83161.57	87319.65	91685.63	96269.91
			36.2644	38.0776	39.9815	41.9806	44.0796	46.28361
Human Resources Analyst	CL	286	5293.14	5557.80	5835.69	6127.47	6433.85	6755.54
			2442.99	2565.14	2693.40	2828.06	2969.47	3117.94
			63517.71	66693.59	70028.27	73529.69	77206.17	81066.48
			30.5374	32.0642	33.6674	35.3508	37.1184	38.9743
Human Resources Assistant	CL	155c	3460.16	3633.17	3814.83	4005.57	4205.85	4416.14
			1597.00	1676.85	1760.69	1848.73	1941.16	2038.22
			41521.96	43598.06	45777.96	48066.86	50470.20	52993.71
			19.9625	20.9606	22.0086	23.1091	24.2645	25.4777
Human Resources Director	DD	335b	9284.85	9749.09	10236.55	10748.37	11285.79	11850.08
			4285.32	4499.58	4724.56	4960.79	5208.83	5469.27
			111418.20	116989.10	122838.56	128980.49	135429.51	142200.99
			53.5664	56.2448	59.0570	62.0099	65.1103	68.3659
Human Resources Technician I	CL	236	4219.85	4430.84	4652.39	4885.01	5129.26	5385.72
			1947.62	2045.01	2147.26	2254.62	2367.35	2485.72
			50638.22	53170.14	55828.64	58620.07	61551.08	64628.63
			24.3453	25.5626	26.8407	28.1827	29.5919	31.0715
Human Resources Technician II	CL	237	4479.69	4703.67	4938.85	5185.80	5445.09	5717.34
			2067.55	2170.92	2279.47	2393.44	2513.12	2638.77
			53756.23	56444.04	59266.24	62229.55	65341.03	68608.08
			25.8443	27.1366	28.4934	29.9181	31.4140	32.9847
Mechanic I	MU	180a	3519.34	3695.31	3880.07	4074.08	4277.78	4491.67
			1624.31	1705.53	1790.80	1880.34	1974.36	2073.08
			42232.07	44343.67	46560.86	48888.90	51333.35	53900.01
			20.3039	21.3191	22.3850	23.5043	24.6795	25.9135
Mechanic II	MU	205a	3950.36	4147.87	4355.27	4573.03	4801.68	5041.77
			1823.24	1914.40	2010.12	2110.63	2216.16	2326.97
			47404.28	49774.50	52263.22	54876.38	57620.20	60501.21
			22.7905	23.9300	25.1265	26.3829	27.7020	29.0871

**SALARY SCHEDULE BY MONTHLY/BI-WEEKLY/ANNUAL/HOURLY RATES PER STEP  
SCHEDULE A-26 EFFECTIVE JUNE 19, 2025**

	Class	Grade	Step 1	Step 2	Step 3	Step 4	Step 5	Step 6
Parks Maintenance Worker I	MU	165b	3362.42	3530.55	3707.07	3892.43	4087.05	4291.40
			1551.89	1629.48	1710.96	1796.50	1886.33	1980.65
			40349.09	42366.54	44484.87	46709.11	49044.57	51496.80
			19.3986	20.3685	21.3870	22.4563	23.5791	24.7581
Parks Maintenance Worker II	MU	190	3686.68	3871.01	4064.56	4267.79	4481.18	4705.24
			1701.54	1786.62	1875.95	1969.75	2068.24	2171.65
			44240.10	46452.11	48774.71	51213.45	53774.12	56462.83
			21.2693	22.3327	23.4494	24.6219	25.8529	27.1456
Planning Technician	MU	225c	3763.58	3951.76	4149.35	4356.82	4574.66	4803.39
			1737.04	1823.89	1915.08	2010.84	2111.38	2216.95
			45163.00	47421.15	49792.21	52281.82	54895.91	57640.70
			21.7130	22.7986	23.9386	25.1355	26.3923	27.7119
Police Chief	DD	338	12562.53	13190.66	13850.19	14542.70	15269.84	16033.33
			5798.09	6088.00	6392.40	6712.02	7047.62	7400.00
			150750.41	158287.93	166202.33	174512.45	183238.07	192399.97
			72.4762	76.1000	79.9050	83.9002	88.0952	92.5000
Police Clerk I	PU	140b	3088.72	3243.16	3405.32	3575.58	3754.36	3942.08
			1425.56	1496.84	1571.68	1650.27	1732.78	1819.42
			37064.68	38917.91	40863.81	42907.00	45052.35	47304.97
			17.8196	18.7105	19.6461	20.6284	21.6598	22.7428
Police Clerk II	PU	155b	3396.17	3565.98	3744.28	3931.49	4128.07	4334.47
			1567.46	1645.84	1728.13	1814.54	1905.26	2000.53
			40754.06	42791.76	44931.35	47177.92	49536.81	52013.65
			19.5933	20.5730	21.6016	22.6817	23.8158	25.0066
Police Corporal	PU	244	6698.93	7033.88	7385.57	7754.85	8142.59	8549.72
			3091.81	3246.41	3408.73	3579.16	3758.12	3946.03
			80387.18	84406.54	88626.87	93058.21	97711.12	102596.67
			38.6477	40.5801	42.6091	44.7395	46.9765	49.3253
Police Officer	PU	230	5907.90	6203.30	6513.46	6839.13	7181.09	7540.15
			2726.72	2863.06	3006.21	3156.52	3314.35	3480.07
			70894.81	74439.56	78161.53	82069.61	86173.09	90481.74
			34.0840	35.7882	37.5777	39.4565	41.4294	43.5008
Police Officer Recruit	PU	116	4278.31	4492.22	4716.84	4952.68	5200.31	5460.33
			1974.60	2073.33	2177.00	2285.85	2400.14	2520.15
			51339.70	53906.69	56602.02	59432.12	62403.73	65523.91
			24.6825	25.9167	27.2125	28.5731	30.0018	31.5019
Police Lieutenant	MM	315	9295.29	9760.06	10248.06	10760.46	11298.48	11863.41
			4290.13	4504.64	4729.87	4966.37	5214.69	5475.42
			111543.49	117120.67	122976.70	129125.54	135581.81	142360.90
			53.6267	56.3080	59.1234	62.0796	65.1836	68.4427
Police Sergeant	PU	295	7771.86	8160.45	8568.47	8996.90	9446.74	9919.08
			3587.01	3766.36	3954.68	4152.41	4360.04	4578.04
			93262.31	97925.43	102821.70	107962.78	113360.92	119028.97
			44.8377	47.0795	49.4335	51.9052	54.5004	57.2255
Project Accountant/Successor Agency Assistant	CU	240b	4370.84	4589.38	4818.85	5059.79	5312.78	5578.42
			2017.31	2118.18	2224.08	2335.29	2452.05	2574.66
			52450.07	55072.57	57826.20	60717.51	63753.39	66941.06
			25.2164	26.4772	27.8011	29.1911	30.6507	32.1832
Public Safety Communications Supervisor	PU	228	5077.71	5331.60	5598.18	5878.09	6171.99	6480.59
			2343.56	2460.74	2583.77	2712.96	2848.61	2991.04
			60932.56	63979.18	67178.14	70537.05	74063.90	77767.10
			29.2945	30.7592	32.2972	33.9120	35.6076	37.3880
Public Safety Dispatcher	PU	170	4132.93	4339.57	4556.55	4784.38	5023.60	5274.78
			1907.51	2002.88	2103.02	2208.18	2318.58	2434.51
			49595.13	52074.89	54678.63	57412.57	60283.19	63297.35
			23.8438	25.0360	26.2878	27.6022	28.9823	30.4314
Public Safety Records Supervisor	PU	227	5077.71	5331.60	5598.18	5878.09	6171.99	6480.59
			2343.56	2460.74	2583.77	2712.96	2848.61	2991.04
			60932.56	63979.18	67178.14	70537.05	74063.90	77767.10
			29.2945	30.7592	32.2972	33.9120	35.6076	37.3880
Public Works Director	DD	325	10755.85	11293.64	11858.32	12451.24	13073.80	13727.49
			4964.24	5212.45	5473.07	5746.72	6034.06	6335.76
			129070.16	135523.66	142299.85	149414.84	156885.58	164729.86
			62.0530	65.1556	68.4134	71.8341	75.4258	79.1970

**SALARY SCHEDULE BY MONTHLY/BI-WEEKLY/ANNUAL/HOURLY RATES PER STEP  
SCHEDULE A-26 EFFECTIVE JUNE 19, 2025**

	Class	Grade	Step 1	Step 2	Step 3	Step 4	Step 5	Step 6
Public Works Superintendent	MM	308b	7291.45	7656.02	8038.82	8440.77	8862.80	9305.94
			3365.28	3533.55	3710.23	3895.74	4090.52	4295.05
			87497.40	91872.28	96465.89	101289.18	106353.64	111671.32
			42.0661	44.1694	46.3778	48.6967	51.1316	53.6881
Recreation Coordinator	MU	186	3863.72	4056.91	4259.76	4472.74	4696.38	4931.20
			1783.26	1872.42	1966.04	2064.34	2167.56	2275.94
			46364.70	48682.93	51117.08	53672.93	56356.58	59174.41
			22.2907	23.4053	24.5755	25.8043	27.0945	28.4492
Recreation Leader	MU	118	2860.00	3003.00	3153.15	3310.81	3476.35	3650.17
			1320.00	1386.00	1455.30	1528.07	1604.47	1684.69
			34320.00	36036.00	37837.80	39729.69	41716.17	43801.98
			16.5000	17.3250	18.1913	19.1008	20.0559	21.0586
Recreation Supervisor	MM	301a	5303.52	5568.70	5847.13	6139.49	6446.46	6768.79
			2447.78	2570.17	2698.68	2833.61	2975.29	3124.06
			63642.26	66824.37	70165.59	73673.87	77357.56	81225.44
			30.5972	32.1271	33.7335	35.4201	37.1911	39.0507
Senior Planner	MM	303	6135.92	6442.71	6764.85	7103.09	7458.25	7831.16
			2831.96	2973.56	3122.24	3278.35	3442.27	3614.38
			73631.00	77312.55	81178.18	85237.09	89498.94	93973.89
			35.3995	37.1695	39.0280	40.9794	43.0283	45.1798
Sewer Division Supervisor	MM	260c	5705.66	5990.94	6290.49	6605.01	6935.26	7282.03
			2633.38	2765.05	2903.30	3048.47	3200.89	3360.94
			68467.90	71891.30	75485.86	79260.15	83223.16	87384.32
			32.9173	34.5631	36.2913	38.1058	40.0111	42.0117
Sewer Maintenance Worker I	MU	180b	3519.34	3695.31	3880.07	4074.08	4277.78	4491.67
			1624.31	1705.53	1790.80	1880.34	1974.36	2073.08
			42232.07	44343.67	46560.86	48888.90	51333.35	53900.01
			20.3039	21.3191	22.3850	23.5043	24.6795	25.9135
Sewer Maintenance Worker II	MU	205b	3872.91	4066.55	4269.88	4483.38	4707.54	4942.92
			1787.50	1876.87	1970.71	2069.25	2172.71	2281.35
			46474.90	48798.64	51238.57	53800.50	56490.53	59315.05
			22.3437	23.4609	24.6339	25.8656	27.1589	28.5169
Streets and Parks Division Supervisor	MM	260d	5705.66	5990.94	6290.49	6605.01	6935.26	7282.03
			2633.38	2765.05	2903.30	3048.47	3200.89	3360.94
			68467.90	71891.30	75485.86	79260.15	83223.16	87384.32
			32.9173	34.5631	36.2913	38.1058	40.0111	42.0117
Streets Maintenance Worker I	MU	165e	3362.42	3530.55	3707.07	3892.43	4087.05	4291.40
			1551.89	1629.48	1710.96	1796.50	1886.33	1980.65
			40349.09	42366.54	44484.87	46709.11	49044.57	51496.80
			19.3986	20.3685	21.3870	22.4563	23.5791	24.7581
Streets Maintenance Worker II	MU	190c	3686.68	3871.01	4064.56	4267.79	4481.18	4705.24
			1701.54	1786.62	1875.95	1969.75	2068.24	2171.65
			44240.10	46452.11	48774.71	51213.45	53774.12	56462.83
			21.2693	22.3327	23.4494	24.6219	25.8529	27.1456
Systems Technician	MU	232	4657.15	4890.01	5134.51	5391.23	5660.80	5943.84
			2149.45	2256.93	2369.77	2488.26	2612.68	2743.31
			55885.81	58680.11	61614.11	64694.82	67929.56	71326.03
			26.8682	28.2116	29.6222	31.1033	32.6584	34.2914
Water Division Supervisor	MM	260e	5705.66	5990.94	6290.49	6605.01	6935.26	7282.03
			2633.38	2765.05	2903.30	3048.47	3200.89	3360.94
			68467.90	71891.30	75485.86	79260.15	83223.16	87384.32
			32.9173	34.5631	36.2913	38.1058	40.0111	42.0117
Water Systems Operator I	MU	180c	3519.34	3695.31	3880.07	4074.08	4277.78	4491.67
			1624.31	1705.53	1790.80	1880.34	1974.36	2073.08
			42232.07	44343.67	46560.86	48888.90	51333.35	53900.01
			20.3039	21.3191	22.3850	23.5043	24.6795	25.9135
Water Systems Operator II	MU	205c	3872.91	4066.55	4269.88	4483.38	4707.54	4942.92
			1787.50	1876.87	1970.71	2069.25	2172.71	2281.35
			46474.90	48798.64	51238.57	53800.50	56490.53	59315.05
			22.3437	23.4609	24.6339	25.8656	27.1589	28.5169
Water Systems Pump Operator	MU	229	4830.16	5071.66	5325.25	5591.51	5871.08	6164.64
			2229.30	2340.77	2457.81	2580.70	2709.73	2845.22
			57961.86	60859.96	63902.95	67098.10	70453.01	73975.66
			27.87	29.26	30.72	32.26	33.87	35.57

**SALARY SCHEDULE BY MONTHLY/BI-WEEKLY/ANNUAL/HOURLY RATES PER STEP  
SCHEDULE A-26 EFFECTIVE JUNE 19, 2025**

	Class	Grade	Step 1	Step 2	Step 3	Step 4	Step 5	Step 6
<b>Seasonal/Temporary Employees:</b>			<b>HOURLY RATES</b>					
Finance Analyst - Special Projects	TL	063	65.00					
Reserve Police Officer	TL	053	22.00					
Reserve Firefighter	TL	051	16.50					
Reserve Firefighter (OES Spec Assig)	TL	099	<b>Minimum hourly rate as defined by CAL OES, at <a href="http://www.caloes.ca.gov">www.caloes.ca.gov</a>.</b>					

CLASS Key:  
 EM - Executive Management  
 DD - Department Director  
 MM - Mid Management  
 CL - Confidential/Unrepresented  
 PU - Police Unit  
 MU - Miscellaneous Unit  
 CU - Clerical Unit  
 SE - Seasonal Employee  
 TL - Temporary/Limited Service

**Note: Any temporary or seasonal employee appointed to a classification on this schedule is not guaranteed the hourly rate listed. The City Manager, at his/her sole discretion, may appoint at a lower hourly rate so long as the hour rate is equal to the mandatory minimum wage rate.**

Adopted by City Council Resolution No. XXXX-25  
 Dated June 9, 2025



## CITY COUNCIL AGENDA REPORT

### CITY COUNCIL

Mike Nelson, Mayor  
Danny Ambriz      Brian Raymond  
John Cale          Kalisa Rochester

**MEETING DATE:** June 9, 2025  
**TO:** Mayor and City Council  
**FROM:** Robert Ayuso, CAL FIRE-Battalion Chief  
**PREPARED BY:** Robert Ayuso, CAL FIRE-Battalion Chief  
**SUBJECT:** **Approving a Cost Share Agreement with Merced County for a Fire Equipment Mechanic (CAL Fire Battalion Chief Ayuso)**

---

### **RECOMMENDED COUNCIL ACTION**

Motion to adopt Resolution No. 3543-25 Approving a Cost Share Agreement, in a form approved by the City Attorney, with the County of Merced, from July 1, 2025, to June 30, 2026, for a Fire Equipment Mechanic for Heavy Equipment in an amount not to exceed \$65,000; and authorizes and directs the City Manager to execute all contract documents on behalf of the City; or

Motion to approve staff's recommendation as presented.

### **I. BACKGROUND/ANALYSIS:**

Maintaining fire apparatus and heavy equipment in peak condition is critical to ensuring operational readiness, emergency response capabilities, and compliance with regulatory standards. Several key operational and financial advantages highlight the long-term value and efficiency of utilizing a county mechanic. While baseline service costs between in-house and vendor repairs may appear similar, the broader operational and financial impacts are not. A dedicated county mechanic offers:

- Faster turnaround times (current average timeframe for simple annual maintenance is 3–4 months)
- Lower parts costs through in-house rebuilding of various parts.
- Improved deployment readiness and revenue opportunities.
- Increased safety and regulatory compliance
- Streamlined recordkeeping and transparency.

Investing in County servicing not only preserves the functionality and lifespan of critical equipment—it enhances the department's ability to respond effectively and generate revenue through mutual aid and state mission participation through Assistance By Hire. Although there will still be times that the apparatus may need to get sent out, it's anticipated that the City will not only have an overall substantial cost savings but also be able to keep equipment in service longer and allow the ability to build revenue through out-of-County requests.

### **II. FISCAL IMPACTS:**

Currently, in fiscal year 24/25, the City has spent approximately \$124,000 in annual

costs on the maintenance and service of the Fire Equipment when outsourcing to a third party. These costs also only account for three of the four heavy fire equipment apparatus to get serviced. Costs for the proposed cost share agreement are budgeted in the proposed 2025-26 budget. \$65,000 is allocated in the Fiscal Year 2025-2026 budget under General Fund-Fire-Professional Services, 0001-2030-3030. The agreement is not to exceed \$65,000 and will be paid based on actual costs.

This item has been reviewed by the Finance Department.

**III. LEGAL REVIEW:**

This item has been reviewed by the City Attorney's Office.

**IV. EXISTING POLICY:**

This item is consistent with goal numbers one (1) and two (2) of the City's Strategic Plan: to ensure the City's continued financial stability and to improve public safety, respectively.

**V. ALTERNATIVES:**

Retain current status of equipment maintenance which consists of outsourcing majority of the repairs and routine maintenance with a third party.

**VI. INTERDEPARTMENTAL COORDINATION:**

N/A

**VII. PUBLIC PARTICIPATION:**

The public will have an opportunity to provide comments on this item prior to City Council action.

**VIII. ENVIRONMENTAL REVIEW:**

This item is not a "project" under the California Environmental Quality Act (CEQA) as this activity does not cause either a direct physical change in the environment, or a reasonably foreseeable indirect physical change in the environment, pursuant to Public Resources Code section 21065.

**IX. STEPS FOLLOWING APPROVAL:**

Following adoption, the City Clerk's office will finalize the Resolution and work with the Fire Department and City Manager's office to fully execute all needed documentation.

Submitted by:



---

Bobby Ayuso, CAL FIRE Battalion Chief  
Approved by:



---

Chris Hoem, City Manager

Attachments:

1. Resolution No. XXXX-25 Cost Share Agreement with County of Merced
2. City of Atwater fire mech 052825 (002)-c1 final



**CITY COUNCIL  
OF THE  
CITY OF ATWATER**

**RESOLUTION NO. XXXX-25**

**A RESOLUTION OF THE CITY COUNCIL OF THE  
CITY OF ATWATER, CALIFORNIA, APPROVING  
A COST SHARE AGREEMENT WITH THE  
COUNTY OF MERCED FROM JULY 1, 2025, TO  
JUNE 30, 2026, FOR A FIRE EQUIPMENT  
MECHANIC FOR HEAVY EQUIPMENT**

**WHEREAS**, the City of Atwater desires to contract with Merced County for special services which consist of a Heavy Equipment Mechanic to perform the duties of a Heavy Equipment Mechanic I/II; and

**WHEREAS**, Merced County is specially trained, experienced, and competent to perform such services in connection with placement of a Heavy Equipment Mechanic; and

**WHEREAS**, the parties anticipate the Heavy Equipment Mechanic's job site will be at a Merced County building/property; and

**WHEREAS**, the parties desire to set forth herein the terms and conditions under which said services shall be furnished.

**NOW, THEREFORE, BE IT RESOLVED** that the City Council of the City of Atwater hereby finds and declares the following:

1. The above recitals are true and correct and incorporated herein by reference.
2. The City Council of the City of Atwater, California approves a Cost Share Agreement, in a form approved by the City Attorney, with the County of Merced, from July 1, 2025, to June 30, 2026, for a Fire Equipment Mechanic for Heavy Equipment in an amount not to exceed \$65,000; and authorizes and directs the City Manager to execute all contract documents on behalf of the City.

The foregoing resolution is hereby adopted this 9<sup>th</sup> day of June 2025.

**AYES:**

**NOES:**

**ABSENT:**

**APPROVED:**

\_\_\_\_\_  
**MIKE NELSON, MAYOR**

**ATTEST:**

\_\_\_\_\_  
**KORY J. BILLINGS, CITY CLERK**

**AGREEMENT FOR SPECIAL SERVICES  
BETWEEN  
COUNTY OF MERCED AND  
THE CITY OF ATWATER**

**CONTRACT NO. \_\_\_\_\_**

**THIS AGREEMENT**, is made and entered into by and between the County of Merced, on behalf of its Fire Department, a political subdivision of the State of California, (hereinafter referred to as "County"), and the City of Atwater, for the purposes set forth below (hereinafter referred to as "City").

**WHEREAS**, City desires to contract with County for special services which consist of a Heavy Equipment Mechanic to perform the duties of a Heavy Equipment Mechanic I/II; and

**WHEREAS**, County is specially trained, experienced, and competent to perform such services in connection with placement of a Heavy Equipment Mechanic; and

**WHEREAS**, the parties anticipate the Heavy Equipment Mechanic's job site will be at a Merced County building/property; and

**WHEREAS**, the parties desire to set forth herein the terms and conditions under which said services shall be furnished.

**NOW, THEREFORE**, in consideration of the mutual covenants and promises herein contained, the parties hereby agree as follows:

**1. SCOPE OF SERVICES**

County shall provide Heavy Equipment Mechanic services in accordance with the terms and conditions stated herein. County's services include, but are not limited to, the following:

Maintenance and Repair:

- Perform scheduled preventative maintenance on fire apparatus and heavy equipment.
- Repair and troubleshoot mechanical issues, including engines, transmissions, brakes, and electrical systems.
- Service firefighting-specific components, such as pumps, foam systems, extrication tools, and auxiliary equipment.

Inspections:

- Conduct annual safety inspections to ensure compliance with NFPA and DOT standards.
- Inspect apparatus readiness and certify that equipment is operationally safe and reliable.

Emergency Repairs:

- Provide rapid response for urgent equipment repairs during incidents.
- Coordinate repairs with department leadership to minimize operational downtime.

Recordkeeping:

- Maintain detailed service logs for all apparatus and equipment, ensuring transparency for both County and City operations.
- Utilize shared software or compatible tracking systems to provide accessible maintenance records.

**2. CITY COVENANTS**

The City acknowledges and agrees that the provision of Heavy Equipment Mechanic services does not relieve either the County or the City of their respective legal obligations under applicable laws. Both parties remain independently responsible for compliance with mandatory reporting laws, including reporting unsafe or unfit equipment, environmental and hazardous waste regulations, workplace safety standards, and vehicle registration and certification requirements. Any legal violations resulting from non-compliance with these laws will be the sole responsibility of the respective agency, and the shared Heavy Equipment Mechanic will promptly report any concerns about potential non-compliance matters to the appropriate agency.

The City acknowledges and agrees that the Heavy Equipment Mechanic, County, or the Merced County Fire Department are not responsible or liable for any matters occurring out of the Heavy Equipment Mechanic’s presence at any City site, at any City or City staff function or activity site, and/or at any location where city officials or its employees are present, unless such matters arise out of or result from the active negligence of the County.

Any overtime request must be approved in advance by the respective County or City Fire Chief or their designee in writing, with a defined scope of service. Overtime approved by the City Fire Chief for afterhours work or service calls will be reimbursed to the County by the City.

**3. TERM**

The term of this Agreement shall commence on the 1st day of July, 2025, and continue until the 30th day of June, 2026, unless sooner terminated in accordance with the sections entitled “TERMINATION FOR CONVENIENCE”, as set forth elsewhere in this Agreement.

**4. COMPENSATION**

The County and the City will each contribute fifty percent (50%) of the total costs associated with the Heavy Equipment Mechanic. This includes the mechanic's base salary, health and retirement benefits, accrued overtime costs, mandatory employer contributions (e.g., payroll taxes and workers' compensation), and any expenses related to required training or certifications. Both parties will review and reconcile these costs on a quarterly basis to ensure accuracy and equitable sharing.

Each agency will independently procure and cover the costs of all necessary parts, materials, and consumables required for the maintenance and repair of their respective apparatus. The Heavy Equipment Mechanic will document all parts and materials used for each repair, and the responsible agency will be invoiced accordingly. Invoices will be itemized and provided monthly, detailing all associated costs for review and reconciliation.

The County and City will equally share the cost of an annual uniform allowance, which will cover uniform purchase, replacement, and maintenance. The allowance amount will be reviewed and agreed upon annually

Any and/or all payments made under this Agreement shall be paid by check, payable to the order of County and be mailed to County at:

Name: Merced County Fire Department  
c/o Merced County Auditor  
Division: Merced County Fire Department  
Address: 2222 M Street  
City/State/Zip: Merced, CA 95340

County may request that City mail the check to County to such other address as County may from time to time designate to City. Such request must be made in writing in accordance with the procedures as outlined under Section 6, "NOTICES".

**5. TERMS OF PAYMENT**

Payment shall be only for full and complete satisfactory performance of the services required to be provided herein and as set forth under Section 1, "SCOPE OF SERVICES." Payment shall be made in the following manner:

County shall submit Quarterly itemized invoices, or alternate documentation as deemed appropriate in advance by City, for services it has provided and for the amount owed under this Agreement. Invoices shall be forwarded to the City at the City address indicated under Section 6, "NOTICES" of this Agreement.

The fee due hereunder shall be paid to County within thirty (30) days following

receipt of a proper invoice.

## **6. NOTICES**

All notices, requests, demands or other communications under this Agreement shall be in writing. Notice shall be sufficiently given for all purposes as follows:

- A. Personal Delivery. When personally delivered to the City, notice is effective upon delivery.
- B. First Class Mail. When mailed first class to the last address of the recipient known to the party giving notice, notice is effective three mail delivery days after deposit in a United States Postal Service office or mailbox.
- C. Certified Mail. When mailed by certified mail, return receipt requested, notice is effective upon receipt, if delivery is confirmed by a return receipt.
- D. Overnight Delivery. When delivered by an overnight delivery service, charges prepaid or charged to the sender's account, notice is effective on delivery, if delivery is confirmed by the delivery service.

Any correctly addressed notice that is refused, unclaimed or undeliverable because of an act or omission of the party to be notified shall be deemed effective as of the first date that the notice was refused, unclaimed or deemed undeliverable by the postal authorities, messengers or overnight delivery service.

Information for notice to the parties to this Agreement at the time of endorsement of this Agreement is as follows:

County of Merced c/o  
Merced County Fire  
2222 "M" Street  
Merced, CA 95340

City of Atwater c/o  
Atwater City Fire  
1160 5th Street  
Atwater, CA 95301

Any party may change its address by giving the other party notice of the change in any manner permitted by this Agreement.

## **7. TERMINATION FOR CONVENIENCE**

This Agreement, notwithstanding anything to the contrary herein above or hereinafter set forth, may be terminated by either party at any time without cause or legal excuse by providing the other party with thirty (30) calendar days written notice of such termination.

Upon effective date of termination, City shall have no further liability to County except for payment for actual services incurred during the performance hereunder.

Such liability is limited to the time specified in said notice and for services not previously reimbursed by City. Such liability is further limited to the extent such costs are actual, necessary, reasonable, and verifiable costs and have been incurred by County prior to, and in connection with, discontinuing the work hereunder.

## **8. MODIFICATION OF THE AGREEMENT**

Notwithstanding any of the provisions of this Agreement, the parties may agree to amend this Agreement. No alteration or variation of the terms of this Agreement shall be valid unless made in writing and signed by the parties hereto. No oral understanding or agreement not incorporated herein shall be binding on any of the parties hereto

## **9. INSURANCE**

Prior to the commencement of work, and as a precondition to this agreement, both parties shall maintain insurance or self-insurance coverage for its wrongful acts, errors and/or omissions arising from the performance of its duties under this agreement with minimum limits of:

Commercial General Liability (CGL) \$1,000,000 per occurrence covering products and completed operations, bodily injury, personal injury and property damage;

Automobile Liability insurance with limits no less than \$1,000,000 per accident for bodily injury and property damage;

and Workers Compensation Insurance as required according to the California Labor Code, including Employers' Liability limits of \$1,000,000 per accident, during the term of the Agreement.

Each Party shall provide the other certificates of insurance upon request. Each Party and its officers, employees and agents shall be endorsed to the other's CGL policy as additional insured, using ISO form CG2026 or an alternate form that is at least as broad as form CG2026, as to any liability arising from their performance of this Agreement.

## **10. INDEMNIFICATION**

The City shall indemnify, defend, and hold harmless the County its officers, officials, employees, and volunteers from and against any and all liability, claims, damage, costs, expenses, awards, fines, judgments, and expenses of litigation (including, without limitation, costs, attorney fees, expert witness fees and prevailing party fees and cost) of every nature arising out of or in connection with the assigned Heavy Equipment Mechanic's performance of work or his or her

failure to comply with any of its obligations contained in the Agreement, except such loss or damage caused by the active negligence by the County or the gross or willful misconduct of the assigned Heavy Equipment Mechanic.

The County shall indemnify, defend, and hold harmless the City its officials, employees, and volunteers from and against any and all liability, claims, damage, costs, expenses, awards, fines, judgments, and expenses of litigation (including, without limitation, costs, attorney fees, expert witness fees and prevailing party fees and cost) of every nature arising out of or in connection with the assigned Heavy Equipment Mechanic's performance of work or his or her failure to comply with any of its obligations contained in the Agreement, except such loss or damage caused by the active negligence by the City.

Where fault is determined to have been comparative, principles of comparative fault will be followed, and each party shall bear the proportionate cost of any damage attributed to the fault of that party, its directors, agents, employees, volunteers, or subcontractors. Each party shall promptly notify the other party of any claims or legal actions arising out of the performance of this Agreement.

If the City rejects a tender of defense by the County and/or the Heavy Equipment Mechanic under this Agreement, and it is later determined that the County and/or the Heavy Equipment Mechanic breached no duty of care and/or was immune from liability, the City shall reimburse the County and/or officer for any and all litigation expenses (including, without limitation, costs, attorney fees, expert witness fees and prevailing party fees and costs). A duty of care or immunity determination may be made by a jury or a court, including a declaratory relief determination by a court after the County and/or officer settles a liability claim, with or without participation by the City.

If the County rejects a tender of defense by the City under this Agreement, and it is later determined that the City breached no duty of care and/or was immune from liability, the County shall reimburse the City and/or officer for any and all litigation expenses (including, without limitation, costs, attorney fees, expert witness fees and prevailing party fees and costs). A duty of care or immunity determination may be made by a jury or a court, including a declaratory relief determination by a court after the City and/or officer settles a liability claim, with or without participation by the County.

The Parties acknowledge that it is not the intent of the Agreement to create a duty of care by the City, or by the County or its assigned employee, that either Party would not owe in the absence of the Agreement. The Agreement does not create an affirmative duty of care by either Party. The Parties further acknowledge that by entering into this Agreement neither Party intends to waive any immunities to which they would be entitled to in absence of the Agreement.

## **11. INDEPENDENT CONTRACTOR**

It is mutually understood and agreed that County is an independent entity in the performance of the work duties and obligations devolving upon County under this Agreement. County shall neither have, nor exercise any control or direction over the methods by which City shall receive and use the services provided. The contractual interest of County is to assure that the services covered by this Agreement shall be performed and rendered in a competent, efficient and satisfactory manner.

It is mutually understood and agreed that no employer-employee relationship is created and each party shall be responsible for withholding, reporting and payment of any federal, state or local taxes, contributions or premiums imposed or required by workers' compensation, unemployment insurance, social security, income tax, other statutes or codes applying to the other party, or its employees, if any.

It is mutually agreed and understood that City, its subcontractors and employees, if any, shall have no claim under this Agreement or otherwise against the County for vacation pay, sick leave, retirement or social security benefits, occupational or non-occupational injury, disability or illness, or loss of life or income, by whatever cause.

City shall insure that all its personnel and employees, subcontractors and their employees, and any other individuals used to perform the contracted services are aware and expressly agree that County is not responsible for any benefits, coverage or payment for their efforts.

**12. RECORDS, INFORMATION AND REPORTS**

County shall maintain full and accurate records with respect to all matters, including necessary records related to vehicle repairs and maintenance, covered under this Agreement. To the extent permitted by law, City shall have free access at all proper times or until the expiration of four (4) years after the furnishing of services to such records, and the right to examine and audit the same and to make transcripts therefrom, and to inspect all data, documents, proceedings, and activities pertaining to this Agreement.

**13. ENTIRE AGREEMENT**

This Agreement and any additional or supplementary document or documents incorporated herein by specific reference contain all the terms and conditions agreed upon by the parties hereto, and no other contracts, oral or otherwise, regarding the subject matter of this Agreement or any part thereof shall have any validity or bind any of the parties hereto.

**14. COUNTY NOT OBLIGATED TO THIRD PARTIES**

County shall not be obligated or liable hereunder to any party other than City.

**15. LAWS, LICENSES, PERMITS AND REGULATIONS**

The parties agree to comply with all State laws and regulations that pertain to construction, health and safety, labor, minimum wage, fair employment practice, equal opportunity, and all other matters applicable to the parties, their subgrantees, contractors, or subcontractor, and their work.

**16. APPLICABLE LAW; VENUE**

All parties agree that this Agreement and all documents issued or executed pursuant to this Agreement as well as the rights and obligations of the parties hereunder are subject to and governed by the laws of the State of California in all respects as to interpretation, construction, operation, effect and performance. No interpretation of any provision of this Agreement shall be binding upon County unless agreed in writing by County and counsel for County.

Notwithstanding any other provision of this Agreement, any disputes concerning any question of fact or law arising under this Agreement or any litigation or arbitration arising out of this Agreement, shall be tried in Merced County, unless the parties agree otherwise or are otherwise required by law.

**17. BREACH OF CONTRACT**

Upon breach of this Agreement by City, County shall have all remedies available to it both in equity and/or at law.

**18. SUCCESSORS IN INTEREST**

All the terms, covenants, and conditions of this Agreement shall be binding and in full force and effect upon any successors in interest and assigns of the parties hereto. This paragraph shall not be deemed as a waiver of any of the conditions against assignment set forth herein.

**19. NONDISCRIMINATION IN EMPLOYMENT, SERVICES, BENEFITS AND FACILITIES**

The parties and any subcontractors shall comply with all applicable federal, state, and local Anti-discrimination laws, regulations, and ordinances and shall not unlawfully discriminate, deny family care leave, harass, or allow harassment against any employee, applicant for employment, employee or agent of County, or recipient of services contemplated to be provided or provided under this Agreement, because of race, ancestry, marital status, color, religious creed, political belief, national origin, ethnic group identification, sex, sexual orientation, age (over 40), medical condition (including HIV and AIDS), or physical or mental

disability. Each party shall ensure that the evaluation and treatment of its employees and applicants for employment, the treatment of County employees and agents, and recipients of services are free from such discrimination and harassment.

The parties represent that they are in compliance with and agree that they will continue to comply with the Americans with Disabilities Act of 1990 (42 U.S.C. § 12101 et seq.), the Fair Employment and Housing Act (Government Code §§ 12900 et seq.), and ensure a workplace free of sexual harassment pursuant to Government Code 12950 and regulations and guidelines issued pursuant thereto.

The parties shall include this nondiscrimination provision in all subcontracts related to this Agreement.

**20. CAPTIONS**

The captions of each paragraph in this Agreement are inserted as a matter of convenience and reference only, and in no way define, limit, or describe the scope or intent of this Agreement or in any way affect it.

**21. SEVERABILITY**

If a court of competent jurisdiction holds any provision of this Agreement to be illegal, unenforceable or invalid, in whole or in part, for any reason, the validity and enforceability of the remaining provisions, or portion of them, will not be affected. Reduced compensation will allow County to withdraw from any service obligation.

**22. DUPLICATE COUNTERPARTS**

This Agreement may be executed in duplicate counterparts, each of which shall be deemed a duplicate original. The Agreement shall be deemed executed when it has been signed by both parties.

**23. LICENSE AND PERMITS**

City shall possess and maintain all necessary licenses, permits, certificates and credentials required by the laws of the United States, the State of California, County of Merced and all other appropriate governmental agencies, including any certification and credentials required by County. Failure to maintain the licenses, permits, certificates, and credentials shall be deemed a breach of this Agreement and constitutes grounds for the termination of this Agreement by County.

*Signature page to follow*

County of Merced

City of Atwater

By \_\_\_\_\_  
Joshua M. Pedrozo  
Board Chair, Board of Supervisors

By \_\_\_\_\_  
Michael Nelson, Mayor

\_\_\_\_\_  
Dated

\_\_\_\_\_  
Dated

APPROVED AS TO LEGAL FORM  
MERCED COUNTY COUNSEL

By \_\_\_\_\_  
Rina M. Gonzales  
Chief Deputy County Counsel

\_\_\_\_\_  
Dated



## CITY COUNCIL AGENDA REPORT

### CITY COUNCIL

Mike Nelson, Mayor  
Danny Ambriz      Brian Raymond  
John Cale          Kalisa Rochester

**MEETING DATE:** June 9, 2025  
**TO:** Mayor and City Council  
**FROM:** Justin Vinson, Public Works Director  
**PREPARED BY:** Justin Vinson, Public Works Director  
**SUBJECT:** **Awarding a General Construction Contract with Consolidated Engineering Inc. for Olive Avenue Overlay** (Public Works Director Vinson)

### **RECOMMENDED COUNCIL ACTION**

Motion to adopt a Resolution 3542-25 awarding a General Construction Contract, in a form approved by the City Attorney, to Consolidated Engineering Inc. of Valley Springs, CA, for the Olive Avenue Overlay Project, City Project 24-07, in an amount not to exceed \$447,327.00 and authorizes construction contract change orders up to an aggregate amount of \$44,732.70 (10%); and authorizes and directs the Interim City Manager or designee to execute all contract documents on behalf of the City; or

Motion to approve staff's recommendations as presented.

### **I. BACKGROUND/ANALYSIS:**

All pavements deteriorate with the passage of time and application of traffic loads. The rate of deterioration is based on a complex interaction of many factors including, amount of traffic, pavement structure, materials used in construction, subgrade conditions and localized factors. Over the years, the deterioration of the roadways has been caused by a combination of climate and load-related distress. Climate-related distress in particular is due to weathering of asphalt concrete pavement and load-related distress such as rutting and alligator cracking.

In 2018, Dynatest performed a network-level condition survey of the City's pavements and used the Pavement Condition Index (PCI) method in assessing the condition of the City's pavements. The PCI method is a more objective and repeatable method for assessing pavement conditions and is widely used in the industry. The condition assessment of Olive Avenue, between Winton Way and the city limits, resulted in a very poor condition. If funding wasn't an issue, staff would recommend a full reconstruction of this section of Olive Avenue due to the poor condition of the roadway, but since the city is limited in funds, especially in its Gas Tax Fund, staff is recommending an overlay on both streets.

The specifications and scope of work included in the overlay of Olive Ave will consist of grinding the existing asphalt concrete, installation of an asphalt paving mat, and an overlay of 1 1/2" of asphalt concrete over the mat. This is approximately 185,650 square feet of pavement overlay. This will also include approximately 50 feet of overlay on intersecting streets that do not have a valley gutter. The estimated cost of construction was \$696,000 for the bid.

Bid proposals for this project were opened on Thursday, May 15, 2025, at 2:00 P.M. and were totaled and reviewed for responsiveness. Six (6) bid proposals were received. The Bid Summary (Exhibit "A") shows the bid amounts ranging from \$447,327.00 to \$681,277.00.

Staff has reviewed the bids and determined that the bid submitted by Consolidated Engineering Inc. of Valley Springs, California in the amount of \$447,327.00 is a responsive and acceptable bid.

The recommended contract administration practice is to include 10% of the bid amount as contingency funds for unforeseen and necessary changes to the contract. Staff is recommending a total construction budget of \$492,059.70. This total budget includes the construction contract amount of \$447,327.00 for bid items and \$44,732.70 contingency with contractor.

**II. FISCAL IMPACTS:**

Sufficient funding for this project is available in the Local Transportation Fund, Regional Surface Transportation Fund, and SB-1 Road Maintenance and Rehab Fund Olive Ave Overlay Account No's. 1013.1080.X014, 1017.1080.X014, and 1018.1080.X014.

This item has been reviewed by the Finance Department.

**III. LEGAL REVIEW:**

This item has been reviewed by the City Attorney's Office.

**IV. EXISTING POLICY:**

This item consists of goals number one (1) and two (2) of the City's Strategic Plan; to ensure the City's continued financial stability and to improve public safety, respectively.

**V. ALTERNATIVES:**

N/A

**VI. INTERDEPARTMENTAL COORDINATION:**

This item has been reviewed by all departments.

**VII. PUBLIC PARTICIPATION:**

The public will have an opportunity to provide comments on this item prior to City Council action.

**VIII. ENVIRONMENTAL REVIEW:**

This project is Categorically Exempt (CE) pursuant to the California Environmental Quality Control Act (CEQA) guidelines, Section 15301, Class 1(c): Operation, repair, maintenance, or minor alteration to existing highways and streets, sidewalks, gutters, bicycle and pedestrian trails, and similar facilities.

**IX. STEPS FOLLOWING APPROVAL:**

Following City Council's approval for the award of contract, staff will issue a notice of award to the contractor, hold a pre-construction meeting, and issue a notice to proceed, with construction to follow.

Submitted by:



---

Justin Vinson, Public Works Director

Approved by:



---

Chris Hoem, City Manager

Attachments:

1. 24-07 Bid Summary
2. Resolution XXXX-25 Awarding Construction Contract with Consolidated Engineering, Inc.
3. Consolidated Engineering, Inc. Construction Contract

CITY OF ATWATER  
PUBLIC WORK DEPARTMENT

# BID SUMMARY

## Olive Avenue Overlay Project

Project No. 24-07; Bid Call No. 733-25

Bid Opening: May 15,2025; Engineer's Estimate: \$696,000.00

No.	Contractor	Base Bid
1	Consolidated Engineering Inc. P.O Box 701 Valley Springs, CA 95252	\$447,327.00
2	Cal Valley Construction 5125 N. Gates Ave. Suite 102 Fresno, CA 93722	\$549,760.00
3	United Pavement Maintenance P.O Box 1017 Hughson, CA 95326	\$574,669.00
4	Rolfe Construction 3573 Southern Pacific Ave Atwater, CA 95301	\$598,341.00
5	Agee Construction Corporation P.O Box 629 Clovis, CA 93613	\$608,124.00
6	Machado & Sons Construction Inc. 1000 S. Kilroy Road Turlock, CA 95380	\$681,277.00



**CITY COUNCIL  
OF THE  
CITY OF ATWATER**

---

**RESOLUTION NO. XXXX-25**

**A RESOLUTION OF THE CITY COUNCIL OF THE CITY OF  
ATWATER AWARDING A GENERAL CONSTRUCTION  
AGREEMENT TO CONSOLIDATED ENGINEERING INC OF  
VALLEY SPRINGS, CA FOR OLIVE AVENUE OVERLAY  
PROJECT**

**WHEREAS**, Olive Avenue is a street located in the City of Atwater and the County of Merced; and

**WHEREAS**, the pavement on Olive Avenue is in very poor condition; and

**WHEREAS**, there is approximately 185,650 square feet of pavement that needs replacement; and

**WHEREAS**, the work also includes wedge grinding, restriping, and installing geosynthetic fabric below the new asphalt; and

**WHEREAS**, The city received six bids for the project with Consolidated Engineering, Inc. coming in as the lowest responsive and responsible bidder at \$447,327.00.

**NOW, THEREFORE, BE IT RESOLVED** that the City Council of the City of Atwater does hereby award a General Construction Agreement, in a form approved by the City Attorney, to Consolidated Engineering, Inc. of Valley Springs, CA in an amount not to exceed \$447,327.00 and 10% contingency of \$44,732.70 for the Olive Avenue Overlay Project.

The foregoing resolution is hereby adopted this 9<sup>th</sup> day of June 2025.

**AYES:**

**NOES:**

**ABSENT:**

**APPROVED:**

\_\_\_\_\_  
**MIKE NELSON, MAYOR**

**ATTEST:**

\_\_\_\_\_  
**KORY J. BILLINGS, CITY CLERK**

**CITY OF ATWATER**  
**CONSTRUCTION CONTRACT**  
**OLIVE AVENUE OVERLAY**

**1. PARTIES AND DATE.**

This Contract is made and entered into this 9<sup>th</sup> day of June, 2025 by and between the City of Atwater, a public agency of the State of California (“City”) and Consolidated Engineering, Inc., a contractor with its principal place of business in Valley Springs, California (“Contractor”). City and Contractor are sometimes individually referred to as “Party” and collectively as “Parties” in this Contract.

**2. RECITALS.**

2.1 City. City is a public agency organized under the laws of the State of California, with power to contract for services necessary to achieve its purpose.

2.2 Contractor. Contractor desires to perform and assume responsibility for the provision of certain construction services required by the City on the terms and conditions set forth in this Contract. Contractor represents that it is duly licensed and experienced in providing heating ventilating and air conditioning related construction services to public clients, that it and its employees or subcontractors have all necessary licenses and permits to perform the services in the State of California, and that it is familiar with the plans of City. The following license classifications are required for this Project: Class A or C-12 License.

2.3 Project. City desires to engage Contractor to render such services for the Olive Avenue Overlay Project (“Project”) as set forth in this Contract.

2.4 Project Documents & Certifications. Contractor has obtained, and delivers concurrently herewith, a performance bond, a payment bond, and all insurance documentation, as required by the Contract.

**3. TERMS**

3.1 Incorporation of Documents. This Contract includes and hereby incorporates in full by reference the following documents, including all exhibits, drawings, specifications and documents therein, and attachments and addenda thereto:

- Services/Schedule (Exhibit “A”)
- Plans and Specifications (Exhibit “B”)
- Special Conditions (Exhibit “C”)
- Contractor’s Certificate Regarding Workers’ Compensation (Exhibit “D”)
- Public Works Contractor Registration Certification (Exhibit “E”)
- Payment Bond (Exhibit “F”)
- Fleet Compliance Certification. (Exhibit “G”)
- Addenda
- Change Orders executed by the City

3.2 Contractor’s Basic Obligation; Scope of Work. Contractor promises and agrees, at its own cost and expense, to furnish to the City all labor, materials, tools, equipment, services,

and incidental and customary work necessary to fully and adequately complete the Project, including all structures and facilities necessary for the Project or described in the Contract (hereinafter sometimes referred to as the "Work"), for a Total Contract Price as specified pursuant to this Contract. All Work shall be subject to, and performed in accordance with the above referenced documents, as well as the exhibits attached hereto and incorporated herein by reference. The plans and specifications for the Work are further described in Exhibit "B" attached hereto and incorporated herein by this reference. Special Conditions, if any, relating to the Work are described in Exhibit "C" attached hereto and incorporated herein by this reference.

3.2.1 Change in Scope of Work. Any change in the scope of the Work, method of performance, nature of materials or price thereof, or any other matter materially affecting the performance or nature of the Work shall not be paid for or accepted unless such change, addition or deletion is approved in writing by a valid change order executed by the City. Should Contractor request a change order due to unforeseen circumstances affecting the performance of the Work, such request shall be made within five (5) business days of the date such circumstances are discovered or shall waive its right to request a change order due to such circumstances. If the Parties cannot agree on any change in price required by such change in the Work, the City may direct the Contractor to proceed with the performance of the change on a time and materials basis.

3.2.2 Substitutions/"Or Equal". Pursuant to Public Contract Code Section 3400(b), the City may make a finding that designates certain products, things, or services by specific brand or trade name. Unless specifically designated in this Contract, whenever any material, process, or article is indicated or specified by grade, patent, or proprietary name or by name of manufacturer, such Specifications shall be deemed to be used for the purpose of facilitating the description of the material, process or article desired and shall be deemed to be followed by the words "or equal."

Contractor may, unless otherwise stated, offer for substitution any material, process or article which shall be substantially equal or better in every respect to that so indicated or specified in this Contract. However, the City may have adopted certain uniform standards for certain materials, processes and articles. Contractor shall submit requests, together with substantiating data, for substitution of any "or equal" material, process or article no later than thirty-five (35) days after award of the Contract. To facilitate the construction schedule and sequencing, some requests may need to be submitted before thirty-five (35) days after award of Contract. Provisions regarding submission of "or equal" requests shall not in any way authorize an extension of time for performance of this Contract. If a proposed "or equal" substitution request is rejected, Contractor shall be responsible for providing the specified material, process or article. The burden of proof as to the equality of any material, process or article shall rest with Contractor.

The City has the complete and sole discretion to determine if a material, process or article is an "or equal" material, process or article that may be substituted. Data required to substantiate requests for substitutions of an "or equal" material, process or article data shall include a signed affidavit from Contractor stating that, and describing how, the substituted "or equal" material, process or article is equivalent to that specified in every way except as listed on the affidavit. Substantiating data shall include any and all illustrations, specifications, and other relevant data including catalog information which describes the requested substituted "or equal" material, process or article, and substantiates that it is an "or equal" to the material, process or article. The substantiating data must also include information regarding the durability and lifecycle cost of the requested substituted "or equal" material, process or article. Failure to submit all the required substantiating data, including the signed affidavit, to the City in a timely fashion will result in the rejection of the proposed substitution.

Contractor shall bear all of the City's costs associated with the review of substitution requests. Contractor shall be responsible for all costs related to a substituted "or equal" material, process or article. Contractor is directed to the Special Conditions (if any) to review any findings made pursuant to Public Contract Code section 3400.

### 3.3 Period of Performance.

3.3.1 Contract Time. Contractor shall perform and complete all Work under this Contract within 30 working days, beginning the effective date of the Notice to Proceed ("Contract Time"). Contractor shall perform its Work in strict accordance with any completion schedule, construction schedule or project milestones developed by the City. Such schedules or milestones may be included as part of Exhibits "A" or "B" attached hereto, or may be provided separately in writing to Contractor. Contractor agrees that if such Work is not completed within the aforementioned Contract Time and/or pursuant to any such completion schedule, construction schedule or project milestones developed pursuant to provisions of the Contract, it is understood, acknowledged and agreed that the City will suffer damage.

3.3.2 Force Majeure. Neither City nor Contractor shall be considered in default of this Contract for delays in performance caused by circumstances beyond the reasonable control of the non-performing party. For purposes of this Contract, such circumstances include but are not limited to, abnormal weather conditions; floods; earthquakes; fire; pandemics or epidemics; war; riots and other civil disturbances; strikes, lockouts, work slowdowns, and other labor disturbances; sabotage or judicial restraint. Should such circumstances occur, the non-performing party shall, within a reasonable time of being prevented from performing, give written notice to the other party describing the circumstances preventing continued performance and the efforts being made to resume performance of this Contract. Contractor's exclusive remedy in the event of delay covered under this section shall be a non-compensable extension of the Contract Time.

3.3.3 Liquidated Damages. Pursuant to Government Code Section 53069.85, Contractor shall pay to the City as fixed and liquidated damages the sum of Five Hundred (\$500) per day for each and every calendar day of delay beyond the Contract Time or beyond any completion schedule, construction schedule or Project milestones established pursuant to the Contract.

3.4 Standard of Performance; Performance of Employees. Contractor shall perform all Work under this Contract in a skillful and workmanlike manner, and consistent with the standards generally recognized as being employed by professionals in the same discipline in the State of California. Contractor represents and maintains that it is skilled in the professional calling necessary to perform the Work. Contractor warrants that all employees and subcontractors shall have sufficient skill and experience to perform the Work assigned to them. Finally, Contractor represents that it, its employees and subcontractors have all licenses, permits, qualifications and approvals of whatever nature that are legally required to perform the Work, including any required business license, and that such licenses and approvals shall be maintained throughout the term of this Contract. As provided for in the indemnification provisions of this Contract, Contractor shall perform, at its own cost and expense and without reimbursement from the City, any work necessary to correct errors or omissions which are caused by Contractor's failure to comply with the standard of care provided for herein. Any employee who is determined by the City to be uncooperative, incompetent, a threat to the safety of persons or the Work, or any employee who fails or refuses to perform the Work in a manner acceptable to the City, shall be promptly removed from the Project by Contractor and shall not be re-employed on the Work.

3.5 Control and Payment of Subordinates; Contractual Relationship. City retains Contractor on an independent contractor basis and Contractor is not an employee of City. Any additional personnel performing the work governed by this Contract on behalf of Contractor shall at all times be under Contractor's exclusive direction and control. Contractor shall pay all wages, salaries, and other amounts due such personnel in connection with their performance under this Contract and as required by law. Contractor shall be responsible for all reports and obligations respecting such additional personnel, including, but not limited to: social security taxes, income tax withholding, unemployment insurance, and workers' compensation insurance.

3.6 City's Basic Obligation. City agrees to engage and does hereby engage Contractor as an independent contractor to furnish all materials and to perform all Work according to the terms and conditions herein contained for the sum set forth above. Except as otherwise provided in the Contract, the City shall pay to Contractor, as full consideration for the satisfactory performance by Contractor of the services and obligations required by this Contract, the below-referenced compensation in accordance with compensation provisions set forth in the Contract.

3.7 Compensation and Payment.

3.7.1 Amount of Compensation. As consideration for performance of the Work required herein, City agrees to pay Contractor the Total Contract Price of **\$447,327.00** ("Total Contract Price") provided that such amount shall be subject to adjustment pursuant to the applicable terms of this Contract or written change orders approved and signed in advance by the City.

3.7.2 Payment of Compensation. If the Work is scheduled for completion in thirty (30) or less calendar days, City will arrange for payment of the Total Contract Price upon completion and approval by City of the Work. If the Work is scheduled for completion in more than thirty (30) calendar days, City will pay Contractor on a monthly basis as provided for herein. On or before the fifth (5th) day of each month, Contractor shall submit to the City an itemized application for payment in the format supplied by the City indicating the amount of Work completed since commencement of the Work or since the last progress payment. These applications shall be supported by evidence which is required by this Contract and such other documentation as the City may require. The Contractor shall certify that the Work for which payment is requested has been done and that the materials listed are stored where indicated. Contractor may be required to furnish a detailed schedule of values upon request of the City and in such detail and form as the City shall request, showing the quantities, unit prices, overhead, profit, and all other expenses involved in order to provide a basis for determining the amount of progress payments.

3.7.3 Prompt Payment. City shall review and pay all progress payment requests in accordance with the provisions set forth in Section 20104.50 of the California Public Contract Code. However, no progress payments will be made for Work not completed in accordance with this Contract. Contractor shall comply with all applicable laws, rules and regulations relating to the proper payment of its employees, subcontractors, suppliers or others.

3.7.4 Contract Retentions. From each approved progress estimate, five percent (5%) will be deducted and retained by the City, and the remainder will be paid to Contractor. All Contract retention shall be released and paid to Contractor and subcontractors pursuant to California Public Contract Code Section 7107.

3.7.5 Other Retentions. In addition to Contract retentions, the City may deduct from each progress payment an amount necessary to protect City from loss because of: (1) liquidated damages which have accrued as of the date of the application for payment; (2) any sums expended by the City in performing any of Contractor's obligations under the Contract which

Contractor has failed to perform or has performed inadequately; (3) defective Work not remedied; (4) stop notices as allowed by state law; (5) reasonable doubt that the Work can be completed for the unpaid balance of the Total Contract Price or within the scheduled completion date; (6) unsatisfactory prosecution of the Work by Contractor; (7) unauthorized deviations from the Contract; (8) failure of Contractor to maintain or submit on a timely basis proper and sufficient documentation as required by the Contract or by City during the prosecution of the Work; (9) erroneous or false estimates by Contractor of the value of the Work performed; (10) any sums representing expenses, losses, or damages as determined by the City, incurred by the City for which Contractor is liable under the Contract; and (11) any other sums which the City is entitled to recover from Contractor under the terms of the Contract or pursuant to state law, including Section 1727 of the California Labor Code. The failure by the City to deduct any of these sums from a progress payment shall not constitute a waiver of the City's right to such sums.

3.7.6 Substitutions for Contract Retentions. In accordance with California Public Contract Code Section 22300, the City will permit the substitution of securities for any monies withheld by the City to ensure performance under the Contract. At the request and expense of Contractor, securities equivalent to the amount withheld shall be deposited with the City, or with a state or federally chartered bank in California as the escrow agent, and thereafter the City shall then pay such monies to Contractor as they come due. Upon satisfactory completion of the Contract, the securities shall be returned to Contractor. For purposes of this Section and Section 22300 of the Public Contract Code, the term "satisfactory completion of the contract" shall mean the time the City has issued written final acceptance of the Work and filed a Notice of Completion as required by law and provisions of this Contract. Contractor shall be the beneficial owner of any securities substituted for monies withheld and shall receive any interest thereon. The escrow agreement used for the purposes of this Section shall be in the form provided by the City.

3.7.7 Title to Work. As security for partial, progress, or other payments, title to Work for which such payments are made shall pass to the City at the time of payment. To the extent that title has not previously been vested in the City by reason of payments, full title shall pass to the City at delivery of the Work at the destination and time specified in this Contract. Such transferred title shall in each case be good, free and clear from any and all security interests, liens, or other encumbrances. Contractor promises and agrees that it will not pledge, hypothecate, or otherwise encumber the items in any manner that would result in any lien, security interest, charge, or claim upon or against said items. Such transfer of title shall not imply acceptance by the City, nor relieve Contractor from the responsibility to strictly comply with the Contract, and shall not relieve Contractor of responsibility for any loss of or damage to items.

3.7.8 Labor and Material Releases. Contractor shall furnish City with labor and material releases from all subcontractors performing work on, or furnishing materials for, the Work governed by this Contract prior to final payment by City.

3.7.9 Prevailing Wages. Contractor is aware of the requirements of California Labor Code Section 1720 et seq., and 1770 et seq., as well as California Code of Regulations, Title 8, Section 16000 et seq., ("Prevailing Wage Laws"), which require the payment of prevailing wage rates and the performance of other requirements on "public works" and "maintenance" projects. Since the Services are being performed as part of an applicable "public works" or "maintenance" project, as defined by the Prevailing Wage Laws, and since the total compensation is \$1,000 or more, Contractor agrees to fully comply with such Prevailing Wage Laws. City shall provide Contractor with a copy of the prevailing rates of per diem wages in effect at the commencement of this Contract upon request. Contractor shall make copies of the prevailing rates of per diem wages for each craft, classification or type of worker needed to execute the Services available to interested parties upon request, and shall post copies at Contractor's

principal place of business and at the project site. Contractor shall defend, indemnify and hold the City, its officials, officers, employees and agents free and harmless from any claim or liability arising out of any failure or alleged failure to comply with the Prevailing Wage Laws. Contractor and any subcontractor shall forfeit a penalty of up to \$200 per calendar day or portion thereof for each worker paid less than the prevailing wage rates.

3.7.10 Apprenticeable Crafts. When Contractor employs workmen in an apprenticeable craft or trade, Contractor shall comply with the provisions of Section 1777.5 of the California Labor Code with respect to the employment of properly registered apprentices upon public works. The primary responsibility for compliance with said section for all apprenticeable occupations shall be with Contractor. The Contractor or any subcontractor that is determined by the Labor Commissioner to have knowingly violated Section 1777.5 shall forfeit as a civil penalty an amount not exceeding \$100 for each full calendar day of noncompliance, or such greater amount as provided by law.

3.7.11 Hours of Work. Contractor is advised that eight (8) hours labor constitutes a legal day's work. Pursuant to Section 1813 of the California Labor Code, Contractor shall forfeit a penalty of \$25.00 per worker for each day that each worker is permitted to work more than eight (8) hours in any one calendar day and forty (40) hours in any one calendar week, except when payment for overtime is made at not less than one and one-half (1-1/2) times the basic rate for that worker.

3.7.12 Payroll Records. Contractor and each subcontractor shall keep an accurate payroll record, showing the name, address, social security number, work classification, straight time and overtime hours worked each day and week, and the actual per diem wages paid to each journeyman, apprentice, worker, or other employee employed by him or her in connection with the public work. The payroll records shall be certified and shall be available for inspection at all reasonable hours at the principal office of Contractor in the manner provided in Labor Code section 1776. In the event of noncompliance with the requirements of this section, Contractor shall have 10 days in which to comply subsequent to receipt of written notice specifying in what respects such Contractor must comply with this section. Should noncompliance still be evident after such 10-day period, Contractor shall, as a penalty to City, forfeit not more than \$100.00 for each calendar day or portion thereof, for each worker, until strict compliance is effectuated. The amount of the forfeiture is to be determined by the Labor Commissioner. A contractor who is found to have violated the provisions of law regarding wages on Public Works with the intent to defraud shall be ineligible to bid on Public Works contracts for a period of one to three years as determined by the Labor Commissioner. Upon the request of the Division of Apprenticeship Standards or the Division of Labor Standards Enforcement, such penalties shall be withheld from progress payments then due. The responsibility for compliance with this section is on Contractor. The requirement to submit certified payroll records directly to the Labor Commissioner under Labor Code section 1771.4 shall not apply to work performed on a public works project that is exempt pursuant to the small project exemption specified in Labor Code Section 1771.4.

3.7.13 Contractor and Subcontractor Registration. Pursuant to Labor Code sections 1725.5 and 1771.1, all contractors and subcontractors that wish to bid on, be listed in a bid proposal, or enter into a contract to perform public work must be registered with the Department of Industrial Relations. No bid will be accepted nor any contract entered into without proof of the contractor's and subcontractors' current registration with the Department of Industrial Relations to perform public work. Contractor is directed to review, fill out and execute the Public Works Contractor Registration Certification attached hereto as Exhibit "E" prior to contract execution. Notwithstanding the foregoing, the contractor registration requirements mandated by Labor Code Sections 1725.5 and 1771.1 shall not apply to work performed on a public works

project that is exempt pursuant to the small project exemption specified in Labor Code Sections 1725.5 and 1771.1.

3.7.14 Labor Compliance; Stop Orders. This Project is subject to compliance monitoring and enforcement by the Department of Industrial Relations. It shall be the Contractor's sole responsibility to evaluate and pay the cost of complying with all labor compliance requirements under this Contract and applicable law. Any stop orders issued by the Department of Industrial Relations against Contractor or any subcontractor that affect Contractor's performance of Work, including any delay, shall be Contractor's sole responsibility. Any delay arising out of or resulting from such stop orders shall be considered Contractor caused delay subject to any applicable liquidated damages and shall not be compensable by the City. Contractor shall defend, indemnify and hold the City, its officials, officers, employees and agents free and harmless from any claim or liability arising out of stop orders issued by the Department of Industrial Relations against Contractor or any subcontractor.

### 3.8 Performance of Work; Jobsite Obligations.

#### 3.8.1 Water Quality Management and Compliance.

3.8.1.1 Water Quality Management and Compliance. Contractor shall keep itself and all subcontractors, staff, and employees fully informed of and in compliance with all local, state and federal laws, rules and regulations that may impact, or be implicated by the performance of the Work including, without limitation, all applicable provisions of the Federal Water Pollution Control Act (33 U.S.C. §§ 1300); the California Porter-Cologne Water Quality Control Act (Cal Water Code §§ 13000-14950); local ordinances regulating discharges of storm water; and any and all regulations, policies, or permits issued pursuant to any such authority regulating the discharge of pollutants, as that term is used in the Porter-Cologne Water Quality Control Act, to any ground or surface water in the State.

3.8.1.2 Compliance with the Statewide Construction General Permit. Contractor shall comply with all conditions of the most recent iteration of the National Pollutant Discharge Elimination System General Permit for Storm Water Discharges Associated with Construction Activity, issued by the California State Water Resources Control Board ("Permit"). It shall be Contractor's sole responsibility to file a Notice of Intent and procure coverage under the Permit for all construction activity which results in the disturbance of more than one acre of total land area or which is part of a larger common area of development or sale. Prior to initiating work, Contractor shall be solely responsible for preparing and implementing a Storm Water Pollution Prevention Plan (SWPPP) as required by the Permit. Contractor shall be responsible for procuring, implementing and complying with the provisions of the Permit and the SWPPP, including the standard provisions, and monitoring and reporting requirements as required by the Permit. The Permit requires the SWPPP to be a "living document" that changes as necessary to meet the conditions and requirements of the job site as it progresses through different phases of construction and is subject to different weather conditions. It shall be Contractor's sole responsibility to update the SWPPP as necessary to address conditions at the project site.

3.8.1.3 Other Water Quality Rules Regulations and Policies. Contractor shall comply with the lawful requirements of any applicable municipality, drainage City, or local agency regarding discharges of storm water to separate storm drain systems or other watercourses under their jurisdiction, including applicable requirements in municipal storm water management programs.

3.8.1.4 Cost of Compliance. Storm, surface, nuisance, or other waters may be encountered at various times during construction of The Work. Therefore, the Contractor, by submitting a Bid, hereby acknowledges that it has investigated the risk arising from such waters, has prepared its Bid accordingly, and assumes any and all risks and liabilities arising therefrom.

3.8.1.5 Liability for Non-Compliance. Failure to comply with the Permit is a violation of federal and state law. Pursuant to the indemnification provisions of this Contract, Contractor hereby agrees to defend, indemnify and hold harmless the City and its officials, officers, employees, volunteers and agents for any alleged violations. In addition, City may seek damages from Contractor for any delay in completing the Work in accordance with the Contract, if such delay is caused by or related to Contractor's failure to comply with the Permit.

3.8.1.6 Reservation of Right to Defend. City reserves the right to defend any enforcement action brought against the City for Contractor's failure to comply with the Permit or any other relevant water quality law, regulation, or policy. Pursuant to the indemnification provisions of this Contract, Contractor hereby agrees to be bound by, and to reimburse the City for the costs (including the City's attorney's fees) associated with, any settlement reached between the City and the relevant enforcement entity.

3.8.1.7 Training. In addition to the standard of performance requirements set forth in paragraph 3.4, Contractor warrants that all employees and subcontractors shall have sufficient skill and experience to perform the Work assigned to them without impacting water quality in violation of the laws, regulations and policies described in paragraph 3.8.1. Contractor further warrants that it, its employees and subcontractors will receive adequate training, as determined by City, regarding the requirements of the laws, regulations and policies described in paragraph 3.8.1 as they may relate to the Work provided under this Contract. Upon request, City will provide the Contractor with a list of training programs that meet the requirements of this paragraph.

3.8.2 Safety. Contractor shall execute and maintain its work so as to avoid injury or damage to any person or property. Contractor shall comply with the requirements of the specifications relating to safety measures applicable in particular operations or kinds of work. In carrying out its Work, Contractor shall at all times be in compliance with all applicable local, state and federal laws, rules and regulations, and shall exercise all necessary precautions for the safety of employees appropriate to the nature of the Work and the conditions under which the Work is to be performed. Safety precautions as applicable shall include, but shall not be limited to, adequate life protection and lifesaving equipment; adequate illumination for underground and night operations; instructions in accident prevention for all employees, such as machinery guards, safe walkways, scaffolds, ladders, bridges, gang planks, confined space procedures, trenching and shoring, fall protection and other safety devices, equipment and wearing apparel as are necessary or lawfully required to prevent accidents or injuries; and adequate facilities for the proper inspection and maintenance of all safety measures. Furthermore, Contractor shall prominently display the names and telephone numbers of at least two medical doctors practicing in the vicinity of the Project, as well as the telephone number of the local ambulance service, adjacent to all telephones at the Project site.

3.8.3 Laws and Regulations. Contractor shall keep itself fully informed of and in compliance with all local, state and federal laws, rules and regulations in any manner affecting the performance of the Contract or the Work, including all Cal/OSHA requirements, and shall give all notices required by law. Contractor shall be liable for all violations of such laws and regulations in connection with Work. If Contractor observes that the drawings or specifications are at variance

with any law, rule or regulation, it shall promptly notify the City in writing. Any necessary changes shall be made by written change order. If Contractor performs any work knowing it to be contrary to such laws, rules and regulations and without giving written notice to the City, Contractor shall be solely responsible for all costs arising therefrom. City is a public entity of the State of California subject to certain provisions of the Health & Safety Code, Government Code, Public Contract Code, and Labor Code of the State. It is stipulated and agreed that all provisions of the law applicable to the public contracts of a municipality are a part of this Contract to the same extent as though set forth herein and will be complied with. Contractor shall defend, indemnify and hold City, its officials, officers, employees and agents free and harmless, pursuant to the indemnification provisions of this Contract, from any claim or liability arising out of any failure or alleged failure to comply with such laws, rules or regulations.

3.8.4 Permits and Licenses. Contractor shall be responsible for securing City permits and licenses necessary to perform the Work described herein, including, but not limited to, any required business license. While Contractor will not be charged a fee for any City permits, Contractor shall pay the City's business license fee, if any. Any ineligible contractor or subcontractor pursuant to Labor Code Sections 1777.1 and 1777.7 may not perform work on this Project.

3.8.5 Trenching Work. If the Total Contract Price exceeds \$25,000 and if the Work governed by this Contract entails excavation of any trench or trenches five (5) feet or more in depth, Contractor shall comply with all applicable provisions of the California Labor Code, including Section 6705. To this end, Contractor shall submit for City's review and approval a detailed plan showing the design of shoring, bracing, sloping, or other provisions to be made for worker protection from the hazard of caving ground during the excavation of such trench or trenches. If such plan varies from the shoring system standards, the plan shall be prepared by a registered civil or structural engineer.

3.8.6 Hazardous Materials and Differing Conditions. As required by California Public Contract Code Section 7104, if this Contract involves digging trenches or other excavations that extend deeper than four (4) feet below the surface, Contractor shall promptly, and prior to disturbance of any conditions, notify City of: (1) any material discovered in excavation that Contractor believes to be a hazardous waste that is required to be removed to a Class I, Class II or Class III disposal site; (2) subsurface or latent physical conditions at the site differing from those indicated by City; and (3) unknown physical conditions of an unusual nature at the site, significantly different from those ordinarily encountered in such contract work. Upon notification, City shall promptly investigate the conditions to determine whether a change order is appropriate. In the event of a dispute, Contractor shall not be excused from any scheduled completion date and shall proceed with all Work to be performed under the Contract, but shall retain all rights provided by the Contract or by law for making protests and resolving the dispute.

3.8.7 Underground Utility Facilities. To the extent required by Section 4215 of the California Government Code, City shall compensate Contractor for the costs of: (1) locating and repairing damage to underground utility facilities not caused by the failure of Contractor to exercise reasonable care; (2) removing or relocating underground utility facilities not indicated in the construction drawings; and (3) equipment necessarily idled during such work. Contractor shall not be assessed liquidated damages for delay caused by failure of City to provide for removal or relocation of such utility facilities.

3.8.8 Air Quality.

Contractor shall fully comply with all applicable laws, rules and regulations in furnishing or using equipment and/or providing services, including, but not limited to, emissions

limits and permitting requirements imposed by the San Joaquin Valley Air Pollution Control District (Air District) and/or California Air Resources Board (CARB). Although the Air District and CARB limits and requirements are more broad, Contractor shall specifically be aware of their application to "portable equipment", which definition is considered by Air District and CARB to include any item of equipment with a fuel-powered engine.

Contractor shall comply, and shall ensure all subcontractors comply, with all applicable requirements of Title 13, California Code of Regulations Division 3, Chapter 9 and all pending amendments ("Regulation").

Throughout the Project, and for three (3) years thereafter, Contractor shall make available for inspection and copying any and all documents or information associated with Contractor's and any subcontractors' fleet including, without limitation, all Certificates of Reported Compliance, fuel/refueling records, maintenance records, emissions records, and any other information the Contractor is required to produce, keep or maintain pursuant to the Regulation upon two (2) calendar days' notice from the City.

Contractor shall indemnify District against any fines or penalties imposed by Air District, CARB, or any other governmental or regulatory agency for violations of applicable laws, rules and/or regulations by Contractor, its subcontractors, or others for whom Contractor is responsible under its indemnity obligations provided for in this Agreement.

**3.8.9 State Recycling Mandates.** Contractor shall comply with State Recycling Mandates. Any recyclable materials/debris collected by the contractor that can be feasibly diverted via reuse or recycling must be hauled by the appropriate handler for reuse or recycling.

**3.9 Completion of Work.** When Contractor determines that it has completed the Work required herein, Contractor shall so notify City in writing and shall furnish all labor and material releases required by this Contract. City shall thereupon inspect the Work. If the Work is not acceptable to the City, the City shall indicate to Contractor in writing the specific portions or items of Work which are unsatisfactory or incomplete. Once Contractor determines that it has completed the incomplete or unsatisfactory Work, Contractor may request a reinspection by the City. Once the Work is acceptable to City, City shall pay to Contractor the Total Contract Price remaining to be paid, less any amount which City may be authorized or directed by law to retain. Payment of retention proceeds due to Contractor shall be made in accordance with Section 7107 of the California Public Contract Code.

**3.10 Claims; Government Code Claim Compliance.**

**3.10.1 Intent.** Effective January 1, 1991, Section 20104 et seq., of the California Public Contract Code prescribes a process utilizing informal conferences, non-binding judicial supervised mediation, and judicial arbitration to resolve disputes on construction claims of \$375,000 or less. Effective January 1, 2017, Section 9204 of the Public Contract Code prescribes a process for negotiation and mediation to resolve disputes on construction claims. The intent of this Section is to implement Sections 20104 et seq. and Section 9204 of the California Public Contract Code. This Section shall be construed to be consistent with said statutes.

**3.10.2 Claims.** For purposes of this Section, "Claim" means a separate demand by the Contractor, after a change order duly requested in accordance with the terms of this Contract has been denied by the City, for (A) a time extension, (B) payment of money or damages arising from Work done by or on behalf of the Contractor pursuant to the Contract, or (C) an amount the payment of which is disputed by the City. A "Claim" does not include any demand for payment for which the Contractor has failed to provide notice, request a change order, or

otherwise failed to follow any procedures contained in the Contract Documents. Claims governed by this Section may not be filed unless and until the Contractor completes all procedures for giving notice of delay or change and for the requesting of a time extension or change order, including but not necessarily limited to the change order procedures contained herein, and Contractor's request for a change has been denied in whole or in part. Claims governed by this Section must be filed no later than fourteen (14) days after a request for change has been denied in whole or in part or after any other event giving rise to the Claim. The Claim shall be submitted in writing to the City and shall include on its first page the following in 16 point capital font: "THIS IS A CLAIM." Furthermore, the claim shall include the documents necessary to substantiate the claim. Nothing in this Section is intended to extend the time limit or supersede notice requirements otherwise provided by contract for the filing of claims, including all requirements pertaining to compensation or payment for extra Work, disputed Work, and/or changed conditions. Failure to follow such contractual requirements shall bar any claims or subsequent lawsuits for compensation or payment thereon.

3.10.3 Supporting Documentation. The Contractor shall submit all claims in the following format:

3.10.3.1 Summary of claim merit and price, reference Contract Document provisions pursuant to which the claim is made

3.10.3.2 List of documents relating to claim:

- (A) Specifications
- (B) Drawings
- (C) Clarifications (Requests for Information)
- (D) Schedules
- (E) Other

3.10.3.3 Chronology of events and correspondence

3.10.3.4 Analysis of claim merit

3.10.3.5 Analysis of claim cost

3.10.3.6 Time impact analysis in CPM format

3.10.3.7 If Contractor's claim is based in whole or in part on an allegation of errors or omissions in the Drawings or Specifications for the Project, Contractor shall provide a summary of the percentage of the claim subject to design errors or omissions and shall obtain a certificate of merit in support of the claim of design errors and omissions.

3.10.3.8 Cover letter and certification of validity of the claim, including any claims from subcontractors of any tier, in accordance with Government Code section 12650 *et seq.*

3.10.4 City's Response. Upon receipt of a claim pursuant to this Section, City shall conduct a reasonable review of the claim and, within a period not to exceed 45 days, shall provide the Contractor a written statement identifying what portion of the claim is disputed and

what portion is undisputed. Any payment due on an undisputed portion of the claim will be processed and made within 60 days after the public entity issues its written statement.

3.10.4.1 If City needs approval from its governing body to provide the Contractor a written statement identifying the disputed portion and the undisputed portion of the claim, and the governing body does not meet within the 45 days or within the mutually agreed to extension of time following receipt of a claim sent by registered mail or certified mail, return receipt requested, City shall have up to three days following the next duly publicly noticed meeting of the governing body after the 45-day period, or extension, expires to provide the Contractor a written statement identifying the disputed portion and the undisputed portion.

3.10.4.2 Within 30 days of receipt of a claim, City may request in writing additional documentation supporting the claim or relating to defenses or claims City may have against the Contractor. If additional information is thereafter required, it shall be requested and provided pursuant to this subdivision, upon mutual agreement of City and the Contractor.

3.10.4.3 City's written response to the claim, as further documented, shall be submitted to the Contractor within 30 days (if the claim is less than \$50,000, within 15 days) after receipt of the further documentation, or within a period of time no greater than that taken by the Contractor in producing the additional information or requested documentation, whichever is greater.

3.10.5 Meet and Confer. If the Contractor disputes City's written response, or City fails to respond within the time prescribed, the Contractor may so notify City, in writing, either within 15 days of receipt of City's response or within 15 days of City's failure to respond within the time prescribed, respectively, and demand an informal conference to meet and confer for settlement of the issues in dispute. Upon receipt of a demand, City shall schedule a meet and confer conference within 30 days for settlement of the dispute.

3.10.6 Mediation. Within 10 business days following the conclusion of the meet and confer conference, if the claim or any portion of the claim remains in dispute, City shall provide the Contractor a written statement identifying the portion of the claim that remains in dispute and the portion that is undisputed. Any payment due on an undisputed portion of the claim shall be processed and made within 60 days after City issues its written statement. Any disputed portion of the claim, as identified by the Contractor in writing, shall be submitted to nonbinding mediation, with City and the Contractor sharing the associated costs equally. City and Contractor shall mutually agree to a mediator within 10 business days after the disputed portion of the claim has been identified in writing, unless the parties agree to select a mediator at a later time.

3.10.6.1 If the Parties cannot agree upon a mediator, each Party shall select a mediator and those mediators shall select a qualified neutral third party to mediate with regard to the disputed portion of the claim. Each Party shall bear the fees and costs charged by its respective mediator in connection with the selection of the neutral mediator.

3.10.6.2 For purposes of this section, mediation includes any nonbinding process, including, but not limited to, neutral evaluation or a dispute review board, in which an independent third party or board assists the Parties in dispute resolution through negotiation or by issuance of an evaluation. Any mediation utilized shall conform to the timeframes in this section.

3.10.6.3 Unless otherwise agreed to by City and the Contractor in writing, the mediation conducted pursuant to this section shall excuse any further obligation under Section 20104.4 to mediate after litigation has been commenced.

3.10.6.4 The mediation shall be held no earlier than the date the Contractor completes the Work or the date that the Contractor last performs Work, whichever is earlier. All unresolved claims shall be considered jointly in a single mediation, unless a new unrelated claim arises after mediation is completed.

3.10.7 Procedures After Mediation. If following the mediation, the claim or any portion remains in dispute, the Contractor must file a claim pursuant to Chapter 1 (commencing with Section 900) and Chapter 2 (commencing with Section 910) of Part 3 of Division 3.6 of Title 1 of the Government Code. For purposes of those provisions, the running of the period of time within which a claim must be filed shall be tolled from the time the Contractor submits his or her written claim pursuant to subdivision (a) until the time the claim is denied, including any period of time utilized by the meet and confer conference or mediation.

3.10.8 Civil Actions. The following procedures are established for all civil actions filed to resolve claims subject to this Section:

3.10.8.1 Within 60 days, but no earlier than 30 days, following the filing or responsive pleadings, the court shall submit the matter to non-binding mediation unless waived by mutual stipulation of both parties or unless mediation was held prior to commencement of the action in accordance with Public Contract Code section 9204 and the terms of these procedures.. The mediation process shall provide for the selection within 15 days by both parties of a disinterested third person as mediator, shall be commenced within 30 days of the submittal, and shall be concluded within 15 days from the commencement of the mediation unless a time requirement is extended upon a good cause showing to the court.

3.10.8.2 If the matter remains in dispute, the case shall be submitted to judicial arbitration pursuant to Chapter 2.5 (commencing with Section 1141.10) of Title 3 of Part 3 of the Code of Civil Procedure, notwithstanding Section 1114.11 of that code. The Civil Discovery Act of 1986 (Article 3 (commencing with Section 2016) of Chapter 3 of Title 3 of Part 4 of the Code of Civil Procedure) shall apply to any proceeding brought under this subdivision consistent with the rules pertaining to judicial arbitration.

3.10.8.3 In addition to Chapter 2.5 (commencing with Section 1141.10) of Title 3 of Part 3 of the Code of Civil Procedure, (A) arbitrators shall, when possible, be experienced in construction law, and (B) any party appealing an arbitration award who does not obtain a more favorable judgment shall, in addition to payment of costs and fees under that chapter, also pay the attorney's fees on appeal of the other party.

3.10.9 Government Code Claims. In addition to any and all contract requirements pertaining to notices of and requests for compensation or payment for extra work, disputed work, claims and/or changed conditions, Contractor must comply with the claim procedures set forth in Government Code sections 900 et seq. prior to filing any lawsuit against the City. Such Government Code claims and any subsequent lawsuit based upon the Government Code claims shall be limited to those matters that remain unresolved after all procedures pertaining to extra work, disputed work, claims, and/or changed conditions have been followed by Contractor. If no such Government Code claim is submitted, or if any prerequisite contractual requirements are not otherwise satisfied as specified herein, Contractor shall be barred from bringing and maintaining a valid lawsuit against the City. A Government Code claim must be filed no earlier than the date the work is completed or the date the Contractor last performs work on the Project, whichever occurs first. A Government Code claim shall be inclusive of all unresolved claims unless a new unrelated claim arises after the Government Code claim is submitted.

3.10.10 Non-Waiver. City's failure to respond to a claim from the Contractor within the time periods described in this Section or to otherwise meet the time requirements of this Section shall result in the claim being deemed rejected in its entirety. City's failure to respond shall not waive City's rights to any subsequent procedures for the resolution of disputed claims.

3.11 Loss and Damage. Except as may otherwise be limited by law, Contractor shall be responsible for all loss and damage which may arise out of the nature of the Work agreed to herein, or from the action of the elements, or from any unforeseen difficulties which may arise or be encountered in the prosecution of the Work until the same is fully completed and accepted by City. In the event of damage proximately caused by an Act of God, as defined by Section 7105 of the Public Contract Code, the City may terminate this Contract pursuant to Section 3.17.3; provided, however, that the City needs to provide Contractor with only one (1) day advanced written notice.

### 3.12 Indemnification.

3.12.1 Scope of Indemnity. To the fullest extent permitted by law, Contractor shall defend, indemnify and hold the City, its officials, employees, agents and authorized volunteers free and harmless from any and all claims, demands, causes of action, suits, actions, proceedings, costs, expenses, liability, judgments, awards, decrees, settlements, loss, damage or injury of any kind, in law or equity, to property or persons, including wrongful death, (collectively, "Claims") in any manner arising out of, pertaining to, or incident to any alleged acts, errors or omissions, or willful misconduct of Contractor, its officials, officers, employees, subcontractors, consultants or agents in connection with the performance of the Contractor's services, the Project or this Contract, including without limitation the payment of all consequential damages, expert witness fees and attorneys' fees and other related costs and expenses. Notwithstanding the foregoing, to the extent required by Civil Code section 2782, Contractor's indemnity obligation shall not apply to liability for damages for death or bodily injury to persons, injury to property, or any other loss, damage or expense arising from the sole or active negligence or willful misconduct of the City or the City's agents, servants, or independent contractors who are directly responsible to the City, or for defects in design furnished by those persons.

3.12.2 Additional Indemnity Obligations. Contractor shall defend, with counsel of City's choosing and at Contractor's own cost, expense and risk, any and all Claims covered by this section that may be brought or instituted against City or its officials, employees, agents and authorized volunteers. In addition, Contractor shall pay and satisfy any judgment, award or decree that may be rendered against City or its officials, employees, agents and authorized volunteers as part of any such claim, suit, action or other proceeding. Contractor shall also reimburse City for the cost of any settlement paid by City or its officials, employees, agents and authorized volunteers as part of any such claim, suit, action or other proceeding. Such reimbursement shall include payment for City's attorney's fees and costs, including expert witness fees. Contractor shall reimburse City and its officials, employees, agents and authorized volunteers, for any and all legal expenses and costs incurred by each of them in connection therewith or in enforcing the indemnity herein provided. Contractor's obligation to indemnify shall not be restricted to insurance proceeds, if any, received by the City, its officials, employees, agents and authorized volunteers.

### 3.13 Insurance.

3.13.1 Time for Compliance. Contractor shall not commence Work under this Contract until it has provided evidence satisfactory to the City that it has secured all insurance required under this section. In addition, Contractor shall not allow any subcontractor to commence work on any subcontract until it has provided evidence satisfactory to the City that the

subcontractor has secured all insurance required under this section. Failure to provide and maintain all required insurance shall be grounds for the City to terminate this Contract for cause.

3.13.2 Minimum Requirements. Contractor shall, at its expense, procure and maintain for the duration of the Contract insurance against claims for injuries to persons or damages to property which may arise from or in connection with the performance of the Work hereunder by Contractor, its agents, representatives, employees or subcontractors. Contractor shall also require all of its subcontractors to procure and maintain the same insurance for the duration of the Contract. Such insurance shall meet at least the following minimum levels of coverage:

3.13.2.1 Minimum Scope of Insurance. Coverage shall be at least as broad as the latest version of the following: (1) *General Liability:* Insurance Services Office Commercial General Liability coverage (occurrence form CG 00 01) OR Insurance Services Office Owners and Contractors Protective Liability Coverage Form (CG 00 09 11 88) (coverage for operations of designated contractor); (2) *Automobile Liability:* Insurance Services Office Business Auto Coverage form number CA 00 01, code 1 (any auto); and (3) *Workers' Compensation and Employer's Liability:* Workers' Compensation insurance as required by the State of California and Employer's Liability Insurance. Policies shall not contain exclusions contrary to this Contract.

3.13.2.2 Minimum Limits of Insurance. Contractor shall maintain limits no less than: (1) *General Liability:* \$2,000,000 per occurrence and \$4,000,000 aggregate for bodily injury, personal injury and property damage; (2) *Automobile Liability:* \$2,000,000 per accident for bodily injury and property damage; and (3) *Workers' Compensation and Employer's Liability:* Workers' compensation limits as required by the Labor Code of the State of California. Employer's Liability limits of \$1,000,000 each accident, policy limit bodily injury or disease, and each employee bodily injury or disease. Defense costs shall be available in addition to the limits. Notwithstanding the minimum limits specified herein, any available coverage shall be provided to the parties required to be named as additional insureds pursuant to this Contract.

3.13.3 Insurance Endorsements. The insurance policies shall contain the following provisions, or Contractor shall provide endorsements (amendments) on forms supplied or approved by the City to add the following provisions to the insurance policies:

3.13.3.1 General Liability. (1) Such policy shall give the City, its officials, employees, agents and authorized volunteers additional insured status using ISO endorsements CG20 10 10 01 plus CG20 37 10 01, or endorsements providing the exact same coverage, with respect to the Work or operations performed by or on behalf of Contractor, including materials, parts or equipment furnished in connection with such work; (2) all policies shall waive or shall permit Contractor to waive all rights of subrogation which may be obtained by the Contractor or any insurer by virtue of payment of any loss or any coverage provided to any person named as an additional insured pursuant to this Contract, and Contractor agrees to waive all such rights of subrogation; and (3) the insurance coverage shall be primary insurance as respects the City, its officials, employees, agents and authorized volunteers, or if excess, shall stand in an unbroken chain of coverage excess of Contractor's scheduled underlying coverage. Any insurance or self-insurance maintained by the City, its officials, employees, agents and authorized volunteers shall be excess of Contractor's insurance and shall not be called upon to contribute with it.

3.13.3.2 Automobile Liability. (1) Such policy shall give the City, its officials, employees, agents and authorized volunteers additional insured status with respect to the ownership, operation, maintenance, use, loading or unloading of any auto owned, leased, hired or borrowed by Contractor or for which Contractor is responsible; (2) all policies shall waive

or shall permit Contractor to waive all rights of subrogation which may be obtained by the Contractor or any insurer by virtue of payment of any loss or any coverage provided to any person named as an additional insured pursuant to this Contract, and Contractor agrees to waive all such rights of subrogation; and (3) the insurance coverage shall be primary insurance as respects the City, its officials, employees, agents and authorized volunteers, or if excess, shall stand in an unbroken chain of coverage excess of Contractor's scheduled underlying coverage. Any insurance or self-insurance maintained by the City, its officials, employees, agents and authorized volunteers shall be excess of Contractor's insurance and shall not be called upon to contribute with it in any way.

3.13.3.3 Workers' Compensation and Employer's Liability Coverage.

The insurer shall agree to waive all rights of subrogation against the City, its officials, employees, agents and authorized volunteers for losses paid under the terms of the insurance policy which arise from work performed by Contractor.

3.13.3.4 All Coverages.

Each insurance policy required by this Contract shall be endorsed to state that: (1) coverage shall not be suspended, voided, reduced or canceled except after thirty (30) days prior written notice by certified mail, return receipt requested, has been given to the City; and (2) any failure to comply with reporting or other provisions of the policies, including breaches of warranties, shall not affect coverage provided to the City, its officials, employees, agents and authorized volunteers.

3.13.4 Separation of Insureds; No Special Limitations.

All insurance required by this Section shall contain standard separation of insureds provisions. In addition, such insurance shall not contain any special limitations on the scope of protection afforded to the City, its officials, employees, agents and authorized volunteers.

3.13.5 Deductibles and Self-Insurance Retentions.

Any deductibles or self-insured retentions must be declared to and approved by the City. Contractor shall guarantee that, at the option of the City, either: (1) the insurer shall reduce or eliminate such deductibles or self-insured retentions as respects the City, its officials, employees, agents and authorized volunteers; or (2) the Contractor shall procure a bond or other financial guarantee acceptable to the City guaranteeing payment of losses and related investigation costs, claims and administrative and defense expenses.

3.13.6 Acceptability of Insurers.

Insurance is to be placed with insurers with a current A.M. Best's rating no less than A-:VII, licensed to do business in California, and satisfactory to the City. Exception may be made for the State Compensation Insurance Fund when not specifically rated.

3.13.7 Verification of Coverage.

Contractor shall furnish City with original certificates of insurance and endorsements effecting coverage required by this Contract on forms satisfactory to the City. The certificates and endorsements for each insurance policy shall be signed by a person authorized by that insurer to bind coverage on its behalf, and shall be on forms supplied or approved by the City. All certificates and endorsements must be received and approved by the City before work commences. The City reserves the right to require complete, certified copies of all required insurance policies, at any time.

3.13.8 Subcontractors.

All subcontractors shall meet the requirements of this Section before commencing Work. Contractor shall furnish separate certificates and endorsements for each subcontractor. Subcontractor policies of General Liability insurance shall name the City, its officials, employees, agents and authorized volunteers as additional insureds using form ISO 20 38 04 13 or endorsements providing the exact same coverage. All coverages

for subcontractors shall be subject to all of the requirements stated herein except as otherwise agreed to by the City in writing.

3.13.9 Reporting of Claims. Contractor shall report to the City, in addition to Contractor's insurer, any and all insurance claims submitted by Contractor in connection with the Work under this Contract.

3.14 Bond Requirements.

3.14.1 Payment Bond. If required by law or otherwise specifically requested by City in Exhibit "C" attached hereto and incorporated herein by reference, Contractor shall execute and provide to City concurrently with this Contract a Payment Bond in an amount required by the City and in a form provided or approved by the City. If such bond is required, no payment will be made to Contractor until the bond has been received and approved by the City.

3.14.2 Performance Bond. If specifically requested by City in Exhibit "C" attached hereto and incorporated herein by reference, Contractor shall execute and provide to City concurrently with this Contract a Performance Bond in an amount required by the City and in a form provided or approved by the City. If such bond is required, no payment will be made to Contractor until the bond has been received and approved by the City.

3.14.3 Bond Provisions. Should, in City's sole opinion, any bond become insufficient or any surety be found to be unsatisfactory, Contractor shall renew or replace the effected bond within (ten) 10 days of receiving notice from City. In the event the surety or Contractor intends to reduce or cancel any required bond, at least thirty (30) days prior written notice shall be given to the City, and Contractor shall post acceptable replacement bonds at least ten (10) days prior to expiration of the original bonds. No further payments shall be deemed due or will be made under this Contract until any replacement bonds required by this Section are accepted by the City. To the extent, if any, that the Total Contract Price is increased in accordance with the Contract, Contractor shall, upon request of the City, cause the amount of the bond to be increased accordingly and shall promptly deliver satisfactory evidence of such increase to the City. If Contractor fails to furnish any required bond, the City may terminate the Contract for cause.

3.14.4 Surety Qualifications. Only bonds executed by an admitted surety insurer, as defined in California Code of Civil Procedure Section 995.120, shall be accepted. If a California-admitted surety insurer issuing bonds does not meet these requirements, the insurer will be considered qualified if it is in conformance with Section 995.660 of the California Code of Civil Procedure, and proof of such is provided to the City.

3.15 Warranty. Contractor warrants all Work under the Contract (which for purposes of this Section shall be deemed to include unauthorized work which has not been removed and any non-conforming materials incorporated into the Work) to be of good quality and free from any defective or faulty material and workmanship. Contractor agrees that for a period of one year (or the period of time specified elsewhere in the Contract or in any guarantee or warranty provided by any manufacturer or supplier of equipment or materials incorporated into the Work, whichever is later) after the date of final acceptance, Contractor shall within ten (10) days after being notified in writing by the City of any defect in the Work or non-conformance of the Work to the Contract, commence and prosecute with due diligence all Work necessary to fulfill the terms of the warranty at its sole cost and expense. Contractor shall act sooner as requested by the City in response to an emergency. In addition, Contractor shall, at its sole cost and expense, repair and replace any portions of the Work (or work of other contractors) damaged by its defective Work or which becomes damaged in the course of repairing or replacing defective Work. For any Work so

corrected, Contractor's obligation hereunder to correct defective Work shall be reinstated for an additional one year period, commencing with the date of acceptance of such corrected Work. Contractor shall perform such tests as the City may require to verify that any corrective actions, including, without limitation, redesign, repairs, and replacements comply with the requirements of the Contract. All costs associated with such corrective actions and testing, including the removal, replacement, and reinstatement of equipment and materials necessary to gain access, shall be the sole responsibility of Contractor. All warranties and guarantees of subcontractors, suppliers and manufacturers with respect to any portion of the Work, whether express or implied, are deemed to be obtained by Contractor for the benefit of the City, regardless of whether or not such warranties and guarantees have been transferred or assigned to the City by separate agreement and Contractor agrees to enforce such warranties and guarantees, if necessary, on behalf of the City. In the event that Contractor fails to perform its obligations under this Section, or under any other warranty or guaranty under this Contract, to the reasonable satisfaction of the City, the City shall have the right to correct and replace any defective or non-conforming Work and any work damaged by such work or the replacement or correction thereof at Contractor's sole expense. Contractor shall be obligated to fully reimburse the City for any expenses incurred hereunder upon demand.

### 3.16 Employee/Labor Certifications.

3.16.1 Contractor's Labor Certification. By its signature hereunder, Contractor certifies that he is aware of the provisions of Section 3700 of the California Labor Code which require every employer to be insured against liability for Worker's Compensation or to undertake self-insurance in accordance with the provisions of that Code, and agrees to comply with such provisions before commencing the performance of the Work. A certification form for this purpose, which is attached to this Contract as Exhibit "D" and incorporated herein by reference, shall be executed simultaneously with this Contract.

3.16.2 Equal Opportunity Employment. Contractor represents that it is an equal opportunity employer and that it shall not discriminate against any employee or applicant for employment because of race, religion, color, national origin, ancestry, sex, age or other interests protected by the State or Federal Constitutions. Such non-discrimination shall include, but not be limited to, all activities related to initial employment, upgrading, demotion, transfer, recruitment or recruitment advertising, layoff or termination.

3.16.3 Verification of Employment Eligibility. By executing this Contract, Contractor verifies that it fully complies with all requirements and restrictions of state and federal law respecting the employment of undocumented aliens, including, but not limited to, the Immigration Reform and Control Act of 1986, as may be amended from time to time, and shall require all subcontractors and sub-subcontractors to comply with the same.

### 3.17 General Provisions.

3.17.1 City's Representative. The City hereby designates the city manager, or his or her designee, to act as its representative for the performance of this Contract ("City's Representative"). City's Representative shall have the power to act on behalf of the City for all purposes under this Contract. Contractor shall not accept direction or orders from any person other than the City's Representative or his or her designee.

3.17.2 Contractor's Representative. Before starting the Work, Contractor shall submit in writing the name, qualifications and experience of its proposed representative who shall be subject to the review and approval of the City ("Contractor's Representative"). Following approval by the City, Contractor's Representative shall have full authority to represent and act on

behalf of Contractor for all purposes under this Contract. Contractor's Representative shall supervise and direct the Work, using his best skill and attention, and shall be responsible for all construction means, methods, techniques, sequences and procedures and for the satisfactory coordination of all portions of the Work under this Contract. Contractor's Representative shall devote full time to the Project and either he or his designee, who shall be acceptable to the City, shall be present at the Work site at all times that any Work is in progress and at any time that any employee or subcontractor of Contractor is present at the Work site. Arrangements for responsible supervision, acceptable to the City, shall be made for emergency Work which may be required. Should Contractor desire to change its Contractor's Representative, Contractor shall provide the information specified above and obtain the City's written approval.

3.17.3 Termination. This Contract may be terminated by City at any time, either with or without cause, by giving Contractor three (3) days advance written notice. In the event of termination by City for any reason other than the fault of Contractor, City shall pay Contractor for all Work performed up to that time as provided herein. In the event of breach of the Contract by Contractor, City may terminate the Contract immediately without notice, may reduce payment to Contractor in the amount necessary to offset City's resulting damages, and may pursue any other available recourse against Contractor. Contractor may not terminate this Contract except for cause. In the event this Contract is terminated in whole or in part as provided, City may procure, upon such terms and in such manner as it may determine appropriate, services similar to those terminated. Further, if this Contract is terminated as provided, City may require Contractor to provide all finished or unfinished documents, data, diagrams, drawings, materials or other matter prepared or built by Contractor in connection with its performance of this Contract. City shall not be liable for any costs other than the charges or portions thereof which are specified herein. Contractor shall not be entitled to payment for unperformed Work including, without limitation, any overhead and profit on the portion of the Work that is terminated and shall not be entitled to damages or compensation of any kind or nature for termination of Work.

3.17.4 Contract Interpretation. Should any question arise regarding the meaning or import of any of the provisions of this Contract or written or oral instructions from City, the matter shall be referred to City's Representative, whose decision shall be binding upon Contractor.

3.17.5 Anti-Trust Claims. This provision shall be operative if this Contract is applicable to California Public Contract Code Section 7103.5. In entering into this Contract to supply goods, services or materials, Contractor hereby offers and agrees to assign to the City all rights, title, and interest in and to all causes of action it may have under Section 4 of the Clayton Act (15 U.S.C. Section 15) or under the Cartwright Act (Chapter 2, commencing with Section 16700, of Part 2 of Division 7 of the Business and Professions Code) arising from purchases of goods, services, or materials pursuant to the Contract. This assignment shall be made and become effective at the time the City tender final payment to Contractor, without further acknowledgment by the Parties.

3.17.6 Notices. All notices hereunder and communications regarding interpretation of the terms of the Contract or changes thereto shall be provided by the mailing thereof by registered or certified mail, return receipt requested, postage prepaid and addressed as follows:

**CONTRACTOR:**

Consolidated Engineering, Inc.  
PO Box 701  
Valley Springs, CA 95252

Attn: Casey Curtin, President

**CITY:**

City of Atwater  
1160 5<sup>th</sup> St  
Atwater, CA 95301  
Attn: City Manager

Any notice so given shall be considered received by the other Party three (3) days after deposit in the U.S. Mail as stated above and addressed to the Party at the above address. Actual notice shall be deemed adequate notice on the date actual notice occurred, regardless of the method of service.

3.17.7 Time of Essence. Time is of the essence in the performance of this Contract.

3.17.8 Assignment Forbidden. Contractor shall not, either voluntarily or by action of law, assign or transfer this Contract or any obligation, right, title or interest assumed by Contractor herein without the prior written consent of City. If Contractor attempts an assignment or transfer of this Contract or any obligation, right, title or interest herein, City may, at its option, terminate and revoke the Contract and shall thereupon be relieved from any and all obligations to Contractor or its assignee or transferee.

3.17.9 No Third Party Beneficiaries. There are no intended third party beneficiaries of any right or obligation assumed by the Parties.

3.17.10 Laws and Venue. This Contract shall be interpreted in accordance with the laws of the State of California. If any action is brought to interpret or enforce any term of this Contract, the action shall be brought in the Superior Court of California for the County of Merced.

3.17.11 Counterparts. This Contract may be executed in counterparts, each of which shall constitute an original.

3.17.12 Successors. The Parties do for themselves, their heirs, executors, administrators, successors, and assigns agree to the full performance of all of the provisions contained in this Contract.

3.17.13 [Reserved]

3.17.14 Solicitation. Contractor maintains and warrants that it has not employed nor retained any company or person, other than a bona fide employee working solely for Contractor, to solicit or secure this Contract. Further, Contractor warrants that it has not paid nor has it agreed to pay any company or person, other than a bona fide employee working solely for Contractor, any fee, commission, percentage, brokerage fee, gift or other consideration contingent upon or resulting from the award or making of this Contract. For breach or violation of this warranty, City shall have the right to terminate this Contract without liability.

3.17.15 Conflict of Interest. Contractor maintains and warrants that it has not employed nor retained any company or person, other than a bona fide employee working solely for Contractor, to solicit or secure this Agreement. Further, Contractor warrants that it has not paid nor has it agreed to pay any company or person, other than a bona fide employee working solely for Contractor, any fee, commission, percentage, brokerage fee, gift or other consideration

contingent upon or resulting from the award or making of this Contract. For breach or violation of this warranty, City shall have the right to rescind this Contract without liability. For the term of this Contract, no official, officer or employee of City, during the term of his or her service with City, shall have any direct interest in this Contract, or obtain any present or anticipated material benefit arising therefrom. In addition, Contractor agrees to file, or to cause its employees or subcontractors to file, a Statement of Economic Interest with the City's Filing Officer as required under state law in the performance of the Work.

3.17.16 Certification of License.

3.17.16.1 Contractor certifies that as of the date of execution of this Contract, Contractor has a current contractor's license of the classification indicated below under Contractor's signature.

3.17.16.2 Contractors are required by law to be licensed and regulated by the Contractors' State License Board which has jurisdiction to investigate complaints against contractors if a complaint regarding a patent act or omission is filed within four (4) years of the date of the alleged violation. A complaint regarding a latent act or omission pertaining to structural defects must be filed within ten (10) years of the date of the alleged violation. Any questions concerning a contractor may be referred to the Registrar, Contractors' State License Board, P.O. Box 26000, Sacramento, California 95826.

3.17.17 Authority to Enter Contract. Each Party warrants that the individuals who have signed this Contract have the legal power, right and authority to make this Contract and bind each respective Party.

3.17.18 Entire Contract; Modification. This Contract contains the entire agreement of the Parties with respect to the subject matter hereof, and supersedes all prior negotiations, understandings or agreements. This Contract may only be modified by a writing signed by both Parties.

3.17.19 Non-Waiver. None of the provisions of this Contract shall be considered waived by either party, unless such waiver is specifically specified in writing.

3.17.20 City's Right to Employ Other Contractors. City reserves right to employ other contractors in connection with this Project or other projects.

**[SIGNATURES ON NEXT PAGE]**

**SIGNATURE PAGE FOR CONSTRUCTION CONTRACT  
BETWEEN THE CITY OF ATWATER  
AND CONSOLIDATED ENGINEERING, INC.**

IN WITNESS WHEREOF, the Parties have entered into this Contract as of the 27<sup>th</sup> day of May, 2025.

City of Atwater

CONSOLIDATED ENGINEERING, INC.

By: \_\_\_\_\_  
Christoper Hoem  
City Manager

By: \_\_\_\_\_  
Its: \_\_\_\_\_

Printed Name: \_\_\_\_\_

ATTEST:

By: \_\_\_\_\_  
Kory J. Billings, City Clerk

APPROVED AS TO FORM:

By: \_\_\_\_\_  
Frank Splendorio, City Attorney

**EXHIBIT "A"**

**SERVICES / SCHEDULE**

<b>ITEM NO.</b>	<b>ITEM</b>	<b>UNIT OF MEASURE</b>	<b>ESTIMATED QUANTITY</b>	<b>UNIT PRICE</b>	<b>TOTAL ITEM PRICE</b>
1	MOBILIZATION	LS	1	\$21,500	\$21,500
2	TEMPORARY TRAFFIC CONTROL	LS	1	\$25,000	\$25,000
3	EROSION, SEDIMENTATION, AND POLLUTION CONTROL	LS	1	\$4,150	\$4,150
4	REMOVE EXISTING TRAFFIC STRIPING AND PAVEMENT MARKINGS	LS	1	\$20,000	\$20,000
5	REMOVE EXISTING AC PAVEMENT (WEDGE GRIND)	LF	10,430	\$1.40	\$14,602
6	REPAIR EXISTING AC PAVEMENT	SF	185,650	\$0.50	\$92,825
7	RAISE EXISTING UTILITIES COVERS TO FINISH GRADE	LS	1	\$53,600	\$53,600
8	1.5" TYPE A HMA OVERLAY WITH PAVEMENT FABRIC	SF	185,650	\$1.00	\$185,650
9	REPLACE TRAFFIC STRIPING AND PAVEMENT MARKINGS	LS	1	\$30,000	\$30,000
<b>TOTAL BID:</b>				\$447,327.00	

**EXHIBIT "B"**  
**PLANS AND SPECIFICATIONS**



## PUBLIC WORKS DEPARTMENT

---

---

### NOTICE TO BIDDERS

AND

### SPECIAL PROVISIONS

for

### Olive Avenue Overlay Project

---

---

For use in conjunction with the STANDARD SPECIFICATIONS, 2024 Edition, and the STANDARD PLANS, 2024 Edition, of the State of California Department of Transportation, and the LABOR SURCHARGE AND EQUIPMENT RENTAL RATES in effect on the date the work is accomplished.

---

---

BID CALL NO.: 733-25

CITY PROJECT NO.: 24-07

BID OPENING: Thursday, May 15, 2025 @ 2:00 P.M. PDT

---

---

*Christopher Hoem*

Chris Hoem  
City Manager

*4-18-25*

Date

**BID BOOK 1 OF 2**

**CITY PROJECT NO. 24-07**

The special provisions contained herein have been prepared by or under the direction of the following Registered Persons.



Michael Hayes, PE



04/22/2025

## TABLE OF CONTENTS

<b>NOTICE TO BIDDERS .....</b>	<b>NTB-1</b>
<b>COPY OF BID ITEM LIST .....</b>	<b>NTB-4</b>
<b>SPECIAL PROVISIONS .....</b>	<b>SP-1</b>
<b>DIVISION I GENERAL PROVISIONS .....</b>	<b>SP-2</b>
1 GENERAL .....	SP-2
2 BIDDING .....	SP-3
3 CONTRACT AWARD AND EXECUTION .....	SP-8
5 CONTROL OF WORK .....	SP-10
7 LEGAL RELATIONS AND RESPONSIBILITY TO THE PUBLIC .....	SP-12
8 PROSECUTION AND PROGRESS.....	SP-14
9 PAYMENT .....	SP-14
<b>DIVISION II GENERAL CONSTRUCTION.....</b>	<b>SP-16</b>
12 TEMPORARY TRAFFIC CONTROL.....	SP-16
13 WATER POLLUTION CONTROL.....	SP-16
14 ENVIRONMENTAL STEWARDSHIP.....	SP-17
15 EXISTING FACILITIES .....	SP-18
<b>DIVISION III EARTHWORK AND LANDSCAPING.....</b>	<b>SP-19</b>
17 GENERAL .....	SP-19
<b>DIVISION IV SUBBASES AND BASES.....</b>	<b>SP-20</b>
23 GENERAL .....	SP-20
<b>DIVISION V SURFACINGS AND PAVEMENTS.....</b>	<b>SP-21</b>
37 SEAL COATS.....	SP-21
39 ASPHALT CONCRETE.....	SP-21
<b>DIVISION VIII MISCELLANEOUS CONSTRUCTION .....</b>	<b>SP-23</b>
77 LOCAL INFRASTRUCTURE .....	SP-23
<b>DIVISION IX TRAFFIC CONTROL DEVICES .....</b>	<b>SP-24</b>
84 MARKINGS.....	SP-24
<b>DIVISION XI MATERIALS.....</b>	<b>SP-25</b>
96 GEOSYNTHETICS.....	SP-25

**CITY OF ATWATER**  
**PUBLIC WORKS DEPARTMENT**  
**NOTICE TO BIDDERS**

Bids open Thursday, May 15, 2025 at 2:00 p.m. Pacific DST

Scope of Work:

The Work generally consists of a 1.5-inch pavement overlay located on Olive Ave between Winton Way and the city limits, including approximately 50 lineal feet of conform overlay paving on each intersecting street (unless intersection street has a valley gutter, then conform will stop at valley gutter). Work includes approximately 185,650 square feet of existing surfaced roadway or approximately 5,267 linear centerline feet of roadway, including side street conforms measured to the centerline of Olive Avenue. All roads included in the project are to be paved "current" to Caltrans standard specifications.

The Work is described in more detail in the following paragraphs and shall be performed by the Contractor pursuant to current Caltrans standard specifications.

All materials and construction methods shall conform to Caltrans Standard Specifications and all applicable material and performance standards therein referenced for hot mix asphalt and other bid items for the intended use and application. Material delivery shall conform to the recommended delivery standards and quality control regarding temperature of materials.

The Contractor shall furnish all labor, materials, equipment, tools, incidentals, permits, services, and construction required to complete the Work, which includes:

- mobilizing all required resources to complete the Work;
- providing temporary traffic control;
- providing erosion, sedimentation, and pollution control;
- removing existing pavement by wedge grind;
- removing existing pavement markers;
- removing existing traffic striping and pavement markings by grinding;
- disposing and/or recycling of all removed and excess materials;
- handling and disposing of any and all hazardous materials;
- repairing and filling existing pavement cracks, potholes, and boils;
- leveling low/depressed areas of existing pavement;
- replacing damaged traffic signal detector loops and lead-in cables;
- raising existing utility covers to finish grade;
- cleaning loose sand, dirt, debris, and other contaminants from existing pavement;
- applying asphalt binder tack coat and sealant;
- installing geosynthetic pavement fabric;
- placing and compacting 1.5" Type A HMA pavement overlay with 1/2" max. aggregate size; and
- replacing thermoplastic traffic striping and pavement markings, and pavement markers.

The newly placed asphalt overlay shall tie in smoothly with the existing road surface and shall be applied to improve or correct any existing drainage issues. Contractor shall maintain the integrity of existing curbs, gutters, drainage inlets, culverts, or any drainage apparatus. Apply the "STOP" word marking and a stop bar line at all existing Stop signs, including where none currently exists.

Contractor shall post notice of the project work schedule at all entrances to the Project work area at least one (1) week prior to commencement of any work. "NO PARKING" signs shall be posted at least 72 hours prior to beginning work. Contractor shall arrange for towing of cars, if necessary, in coordination with City.

Traffic through the active construction zones shall not be delayed more than ten (10) minutes. One travel lane shall be maintained in each direction with a minimum width of 10 feet (10'). Temporary traffic markers shall be used where required and removed completely prior to completion of the Work. Trained flaggers shall be used when required. The project work area shall be cleaned daily of all construction debris, leaving the area safe and ready for traffic.

The City will receive sealed bids for the **OLIVE AVENUE OVERLAY PROJECT**.

Project Number: 24-07  
Bid Call Number: 733-25

Bid forms for this work are included in a separate book titled:

**CITY OF ATWATER, CALIFORNIA  
PUBLIC WORKS DEPARTMENT  
BID BOOK  
FOR THE CONSTRUCTION OF  
OLIVE AVENUE OVERLAY PROJECT**

No bid will be received unless it is made on a bid form furnished by the CITY OF ATWATER PUBLIC WORKS DEPARTMENT. Copies or facsimiles of the bidder's completed and executed bid forms submitted as a bid will be rejected. Each bid must be accompanied by a certified check, cashier's check, or bidder's bond made payable to the CITY OF ATWATER for an amount equal to at least ten percent (10%) of the amount of bid, such guaranty to be forfeited should the bidder to whom the contract is awarded fail to enter into the contract.

The Contractor must have a valid California license of Classification A – General Engineering Contractor, or C-12 – Earthwork and Paving, to perform this work.

The successful bidder will be required to obtain a City of Atwater Business License at his/her own expense before execution of the contract.

Bids must be on a unit price basis. All bids are to be compared on the basis of the CITY OF ATWATER'S estimated quantities of work to be done.

Complete work within **30 working days**.

The estimated cost of construction is **\$696,000**.

Copies of plans, special provisions and proposal forms may only be obtained at the office of the City of Atwater, Engineering Division, located at 750 Bellevue Road, Atwater, CA, (209) 357-6233, upon request and payment of **\$50.00 per set, which is nonrefundable and includes sales tax**.

Electronic copies of the plans and specifications (Adobe PDF file format) for this project are available upon request. Said electronic copies are made available solely for the convenience of the prospective bidders (whether as a prime contractor or sub-contractor) on the Project, and are not considered part of the contract documents. No representation or warranty is made, either expressed or implied, with regard to the accuracy or suitability of said electronic copies for any purpose whatsoever. Utilization or viewing of said electronic copies shall constitute implicit acknowledgement and acceptance of the provisions of this paragraph.

The City will receive sealed bids until 2:00 p.m. PDT on the bid open date at the City of Atwater, Public Works Department, located at 750 Bellevue Road, Atwater, CA 95301. Bids received after this time will not be accepted.

The City will immediately open and publicly read the bids at the mentioned location after the specified closing time.

Present bidders' inquires in writing to Justin Vinson at the City of Atwater, Public Works Department, 750 Bellevue Road, Atwater, CA 95301; email: [jvinson@atwater.org](mailto:jvinson@atwater.org).

Prevailing wages are required on this Contract. The Director of the California Department of Industrial Relations determines the general prevailing wage rates. Obtain the wage rates at the DIR Web site, <https://www.dir.ca.gov/OPRL/DPreWageDetermination.htm>.

The U.S. Department of Transportation (DOT) provides a toll-free hotline to report bid rigging activities. Use the hotline to report bid rigging, bidder collusion, and other fraudulent activities. The hotline number is (800) 424-9071. The service is available 24 hours 7 days a week and is confidential and anonymous. The hotline is part of the DOT's effort to identify and investigate highway construction contract fraud and abuse and is operated under the direction of the DOT Inspector General.

Bidders shall provide certification regarding debarment, suspension, ineligibility and voluntary exclusion. The General Services Administration System for Award Management (SAM) provides a complete, current list of all individuals and firms who are excluded or disqualified from covered transactions by the Federal Government. Visit <https://sam.gov/content/exclusions> for more information.

The CITY OF ATWATER reserves the right to reject any or all bid proposals and to waive any informalities or irregularities in any bid or in the bidding.

City of Atwater



---

Justin Vinson  
Public Works Director

CITY OF ATWATER  
PUBLIC WORKS DEPARTMENT

\*\*\*\*\*

**OLIVE AVENUE OVERLAY PROJECT**

**Project Number: 24-07**

**COPY OF BID ITEM LIST**

(NOT TO BE USED FOR BIDDING PURPOSES)

ITEM NO.	ITEM	UNIT OF MEASURE	ESTIMATED QUANTITY
1	MOBILIZATION	LS	1
2	TEMPORARY TRAFFIC CONTROL	LS	1
3	EROSION, SEDIMENTATION, AND POLLUTION CONTROL	LS	1
4	REMOVE EXISTING TRAFFIC STRIPING AND PAVEMENT MARKINGS	LS	1
5	REMOVE EXISTING AC PAVEMENT (WEDGE GRIND)	LF	10,430
6	REPAIR EXISTING AC PAVEMENT	SF	185,650
7	RAISE EXISTING UTILITIES COVERS TO FINISH GRADE	LS	1
8	1.5" TYPE A HMA OVERLAY WITH PAVEMENT FABRIC	SF	185,650
9	REPLACE TRAFFIC STRIPING AND PAVEMENT MARKINGS	LS	1

**UNITS OF MEASURE**

LS = LUMP SUM

LF = LINEAL FEET

SF = SQUARE FEET

**CITY OF ATWATER  
PUBLIC WORKS DEPARTMENT**

\*\*\*\*\*

**SPECIAL PROVISIONS**

**OLIVE AVENUE OVERLAY PROJECT**

**ORGANIZATION**

This section includes proposed additions, amendments, removals, and revisions to the *Standard Specifications* that are specific to this Contract. They are to be considered a part of the Construction Documents and Project Specifications.

Special provisions are under headings that correspond with the main-section headings of the *Standard Specifications*. A main-section heading is a heading shown in the table of contents of the *Standard Specifications*.

Each special provision begins with a revision clause that describes or introduces a revision to the *Standard Specifications* as revised by any revised standard specification.

Any paragraph added or deleted by a revision clause does not change the paragraph numbering of the *Standard Specifications* for any other reference to a paragraph of the *Standard Specifications*.

^^

# DIVISION I GENERAL PROVISIONS

## 1 GENERAL

### **Add to section 1-1.07B:**

Contract Documents: *Notice to Bidders and Special Provisions, Bid Book, Caltrans Standard Specifications, Project Specifications, Caltrans Standard Plans, Project Plans, and Contract.*

Office Engineer: City Engineer

### **Replace the following definitions in section 1-1.07B:**

Department/Department of Transportation: City of Atwater

Director: The Director of Public Works for the City of Atwater acting either directly or through properly authorized agent or consultants.

District Director of Transportation: The Director of Public Works for the City of Atwater acting either directly or through properly authorized agent or consultants.

Engineer: City Engineer

Specifications: Standard specifications, Special Provisions, and Project Specifications

1. Standard Specifications: Specifications standard to Department construction projects. These specifications are in a book titled Standard Specifications. (Also be referred to as "State Specifications"). The 2024 edition of the Standard Specifications shall apply to this contract.
2. Special Provisions: Proposed amendments, deletions, or additions to the Standard Specifications, included as part of the Bid Book.
3. Project Specifications: Specifications specific to this Project, included as part of the Bid Book.

State: City of Atwater

### **Replace "The Department" in the paragraph 1 of section 1-1.08 with:**

Caltrans

### **Replace section 1-1.12 with:**

Make checks and bonds payable to the City of Atwater.

## 2 BIDDING

### Replace section 2-1.06A with:

#### 2-1.06A General

Locations for obtaining and viewing Contract documents are listed in the Notice to Bidders.

The City will receive sealed bids until 2:00 p.m. PDT on the bid open date at the City of Atwater, Public Works Department, located at 750 Bellevue Road, Atwater, CA 95301. Bids received after this time will not be accepted.

The City will immediately open and publicly read the bids at the above location after the specified bid opening time.

The *Notice to Bidders and Special Provisions* includes the Notice to Bidders and Special Provisions, to be used together with the Standard Specifications and the Standard Plans.

The Contract Documents contain the provisions required for the construction of the Project. Information obtained from an officer, agent, or employee of the City or any other person will not affect the risks or obligations assumed by you or relieve you from fulfilling any of the conditions of the Contract.

A Non-Collusion Affidavit is included in the Bid Book (Public Contract Code § 7106). Signing the bid also constitutes signature of the Non-Collusion Affidavit.

### Add to section 2-1.07:

Examine all of the various parts of these Documents if contemplating the submission of a bid, and should there be any doubt as to the meaning or intent of the Contract Documents, you must request an interpretation, in writing, by **Friday, May 2, 2025, at 5:00 p.m.** Any interpretation or change in the Contract Documents will be made, in the form of addenda to the Documents and will be furnished to all Bidders receiving a set of the Documents. **Addenda will be issued by Wednesday, May 7, 2025 at 5:00 pm.** The City is not responsible for any other explanation or interpretations of the Documents.

Request for interpretation must be submitted in writing to:

**Justin Vinson  
City of Atwater  
Public Works Department  
750 Bellevue Road  
Atwater, California 95301  
Email: jvinson@atwater.org**

### Replace section 2-1.08 with:

#### Section 2-1.08 BID ITEM DESCRIPTIONS

Work under this contract will be paid on a unit price or lump-sum basis as outlined on the Bid Form for the quantity of work constructed or installed.

The unit prices and lump sum prices shall include full compensation for furnishing the labor, materials, tools, equipment, and incidentals and doing all the work involved to complete the work included in the contract documents.

The bids for the work are intended to establish a total cost for the work in its entirety. Should the Contractor feel that the cost for the work has not been established by specific items in the Bid Form, include the cost for that work in some related bid item so that the Proposal for the project reflects the total cost for completing the work in its entirety.

#### Bid Item 1 - Mobilization

This is a lump sum bid item for preparatory work and operations including, but not limited to, those necessary for the movement of personnel, equipment, tools, supplies, and incidentals to the project site; for the establishment of all Contractor's offices, buildings, and other facilities necessary for work on the project; for obtaining permits, bonds, and insurance; and for all other work, operations, and overhead that must be performed and/or costs incurred prior to beginning work on the various contract items on the project site. This item also includes demobilization, including removal of all personnel, equipment, tools, supplies, and incidentals from the project at the end of construction, including final cleanup of the project work area. Payment shall be Progress Payment per Section 9-1.16A and Section 9-1.16D. Payment for mobilization shall be made with the first pay estimate and shall not exceed 80% of the bid amount. Payment for demobilization shall be made with the last (final) pay estimate and shall not exceed 20% of the bid amount.

#### Bid Item 2 – Temporary Traffic Control

This is a lump sum bid item for all costs for preparing and furnishing temporary traffic control plans in accordance with latest edition of Part 6 "Temporary Traffic Control" of the California Manual of Uniform Traffic Control Devices (CA MUTCD), and for furnishing and installing all materials, labor, and equipment necessary to provide traffic regulation in public streets and public alleys and traffic control/access to private properties during construction in accordance with Sections 7-1.03 and 7-1.04 and the special provisions and these Contract Documents. Payment for traffic control/regulation shall be made on a lump sum basis, and no additional payment will be made therefor. Payments shall be prorated over the term of the construction project.

#### Bid Item 3 – Erosion, Sedimentation, and Pollution Control

This is a lump sum bid item for all costs for preparing and furnishing the project Water Pollution Control Program (WPCP) and for furnishing and installing all materials, labor, tools, equipment, and incidentals necessary for compliance with the provisions of the project WPCP in accordance with Section 13 and the special provisions. Payment for this item shall be made on a lump sum basis, and no additional payment will be made therefor. Payments shall be prorated over the term of the construction project. Initial payment shall include the cost for preparing and furnishing the project WPCP.

#### Bid Item 4 –Remove Existing Traffic Striping and Pavement Markings

This is a lump sum bid item for all costs for removal and disposal of existing traffic striping, pavement markings, and pavement markers complete within the project work area. This item will include costs for preparation of a Lead Compliance Plan per Section 7-1.02K(6)(j)(ii) Lead Compliance Plan and for testing and disposal of hazardous waste due to lead and/or metals concentrations in existing traffic striping, pavement markings, and pavement markers. Removal of traffic striping and pavement markings shall be by grinding. Payment for this item shall be made on a lump sum basis and no additional payment shall be due therefor.

#### Bid Item 5 – Remove Existing AC Pavement (Wedge Grind)

This is a unit price bid item for cold planning a wedge grind per Section 39-3.04 at all perimeters of the project work area to provide for a smooth transition of the pavement overlay to meet and match the existing elevations of existing curbs, gutters, and pavements at the edges of the work. The wedge grind shall be one and one quarter inches (1.25") deep adjoining existing gutters and one and one half inches (1.5") deep at the outer perimeter of all other locations and shall taper over a width of 42 inches (42") where parallel to travelled ways and over a width of ten feet (10') where transverse to travelled ways to match existing pavement elevations of the roadways. This item includes the removal and disposal/recycling of existing asphalt pavement as shown in the plans and described in the specifications and scope of work per all applicable sections of the standard specifications and special provisions. This items shall be bid per the units and quantities shown and shall conform to all applicable portions of the plans, specifications, special provisions, and scope of work.

Bid Item 6 – Repair Existing AC Pavement

This is a lump sum bid item to perform crack sealing for all existing AC pavements in the project work area to prepare the existing pavements to a suitable condition for installation of pavement fabric and HMA overlay (bidder shall provide an allowance for up to one hundred and fifty square feet [150 SF] of potholes to be filled). This item also includes replacement of traffic signal detector loops and lead-in cables for the eastbound lanes on Olive Avenue near the intersection of Olive Avenue and Winton Way (see marked as-built plan included with *Bid Book*). Sealing of any pavement cutting required for replacement of traffic signal detector loops and lead-in cables shall be included in the cost of this bid item. The work for this item shall be performed in accordance with all applicable sections of the standard specifications and the special provisions and in accordance with the pavement fabric manufacturer's recommendations. Payment shall be on a lump sum basis and no additional payment shall be due therefor. If it is determined by the Engineer that additional pavement repair beyond crack sealing is required, then this will be accomplished by change order work.

Bid Item 7 – Raise Existing Utilities Covers to Finish Grade

This is a lump sum bid item for adjusting the various existing manhole, valve, and other utility covers at all locations within the Project work area, including the locations shown on the plans and at all other locations necessary due to pavement work. The Contractor shall salvage the existing covers and reconstruct to final pavement grade as per the respective utility agency's requirements. Manhole covers and water valve covers shall be raised in accordance with the City of Atwater Standard Plans.

The bid price for adjusting utility covers shall include full compensation for removing and salvaging existing covers and furnishing all labor, equipment, materials, and incidentals to replace them to permanent finish grade, all as shown on the plans and as specified herein.

Bid Item 8 – 1.5" Type A HMA Overlay with Pavement Fabric

This is a unit price bid item for all costs for surface preparation after crack sealing, installation of pavement fabric including any required application of tack coat binder and sealant, and construction of the 1.5" Type A HMA overlay including placement and compaction for a complete paved roadway overlay. The work for this item shall be performed in accordance with all applicable sections of the standard specifications and the special provisions and in accordance with the pavement fabric manufacturer's recommendations and Caltrans requirements for pavement fabric installation for pavement overlay. Payment shall be based on the unit price for the measured area constructed and no additional payment shall be due therefor.

Bid Item 9 – Replace Traffic Striping and Pavement Markings

This is a lump sum bid item for all costs of furnishing and installing all materials, labor, equipment, and incidentals necessary to install traffic striping, pavement markings, and raised pavement markers in accordance with the Plans, specifications, special provisions, and scope of work to current Caltrans details. All crosswalks shall be the Continental (high visibility) type with 2'-0" wide bars and 2'-0" space between bars. Payment will be made on a lump sum basis, and no additional payment will be made therefor.

**Remove section 2-1.18 in its entirety.**

**Remove section 2-1.27 in its entirety.**

**Replace paragraph 3 of section 2-1.33A with:**

Do not fax forms except for the copies of forms with the public works contractor registration number submitted after the time of bid. Fax these copies to (209) 356-3168.

**Add to the end of section 2-1.33A:**

Submit Bids in a sealed envelope addressed to the City of Atwater, Public Works Department, located at 750 Bellevue Road, Atwater, CA 95301. Each sealed Bid must be plainly marked on the outside as **“BID FOR OLIVE AVENUE OVERLAY PROJECT, Project No. 24-07, to be opened at 2:00 p.m., Thursday, May 15, 2025”**. If submitting by mail, the sealed envelope containing the Bid must be enclosed in another envelope addressed to the City of Atwater, Public Works Department, located at 750 Bellevue Road, Atwater, CA 95301.

All Bids must be made on the required Bid Form. All blank spaces for Bid prices must be filled in, with ink or typewritten, and the Bid Form must be fully completed and executed when submitted. Only one copy of the Bid Form is required.

**Remove lines 7, 8, and 9 from the table titled “Bid Form Submittal Schedule for a Non-Federal-Aid Contract without a DVBE Goal” in section 2-1.33B(3)(c)(ii) Bid Form Submittal Schedule for a Non-Federal-Aid Contract without a DVBE Goal.**

**Replace line 6 of the table titled “Bid Form Submittal Schedule for a Non-Federal-Aid Contract without a DVBE Goal” in section 2-1.33B(3)(c)(ii) Bid Form Submittal Schedule for a Non-Federal-Aid Contract without a DVBE Goal with:**

Local Business Preference Program Certification	Time of Bid
---	-------------

**Replace paragraph 2 of section 2-1.34 with:**

Submit cashier’s check, certified check, or bidder's bond with your Bid.

**Add Section 2-1.35:**

**2-1.35 BID PROTEST**

**2-1.35A General**

Any unsuccessful bidder may submit a bid protest. Bid Protests must be submitted under section 2-1.35B. Bid protests not submitted under section 2-1.35B will not be considered.

**2-1.35B Procedures**

All bid protests must be submitted in writing. Bid Protests must be received no later than 5:00 PM on the tenth (10th) business day following the bid opening.

Deliver bid protest to the following address:

**City of Atwater Public Works Department  
750 Bellevue Road  
Atwater, California 95301**

The following conditions apply to all bid protests:

1. The bid protest must contain a complete statement of the basis for the protest. The bid protest must identify and explain the factual and legal grounds for the protest, state the facts and refer to the specific portion of the document or the specific statute that forms the basis for the protest. Any written materials the protesting bidder believes to be necessary to support the bid protest must be attached to the bid protest. The protest must include the name, address, telephone number, e-mail, and facsimile number of the person representing the protesting party.
2. The party filing the protest must have submitted a bid on the project. A subcontractor of a bidder may not submit a bid protest. A party may not rely on the bid protest submitted by another bidder but must timely pursue their own protest.

3. The protesting bidder and any other bidder on the contract must promptly provide any information requested by the City staff as part of such investigation.
4. The Director of Public Works will provide a written response to the protestor within ten (10) business days after receiving the bid protest. The decision of the Director is final.
5. These bid protest procedures do not limit the City's ability to reject all bids

**Add to section 2-1.40:**

No Bidder may withdraw a Bid within sixty (60) days after the bid opening date. If the contract cannot be awarded within the specified period, the time may be extended by mutual agreement between the City and the Bidder.

**Add to section 2-1.46:**

The City may make such investigations as necessary to determine a Bidder's ability to perform the Work, and the Bidder must furnish to the City all requested information and data for this purpose. The City reserves the right to reject any Bid if it determines a Bidder is unqualified to carry out the obligations of the Agreement and to complete the Work.

## **3 CONTRACT AWARD AND EXECUTION**

### **Add to the end of section 3-1.02A**

If the contract is awarded, the contract shall be awarded to the responsible bidder submitting the lowest responsive bid.

### **Replace section 3-1.02B with:**

The Department breaks a tied bid with a coin toss except:

1. If a local business bidder requesting preference and a non-local business bidder have tied bids after applying the local business preference bid adjustment, the City awards the contract to the local business bidder.

### **Replace section 3-1.04 with:**

#### **3-1.04 CONTRACT AWARD**

If the City awards the contract, the award is made lowest responsible bidder within 30 days after bid opening but not before the close of the 10 days bid protest period.

If the lowest responsible bidder refuses or fails to execute the contract, the award is made to the second lowest responsible bidder.

If the second lowest responsible bidder refuses or fails to execute the contract, the award is made to the third lowest responsible bidder.

The City may extend the specified award period if the bidder agrees.

### **Replace “50 Percent” in item #2 of section 3-1.05 with:**

100 percent

### **Replace Section 3-1.08 with:**

#### **Section 2-1.27 Local Business Preference Program**

##### **Program Description**

In evaluating competitive bids to determine the lowest responsible bidder, if a non-local responsible bidder is initially determined to be the lowest responsible bidder, then any local responsible bidder shall be granted a preference in an amount equal to five percent (5%) of their responsive bid. If after deduction of the five percent (5%) preference from a local bidder's responsive bid, it is equal to or less than the lowest responsive bid submitted by the non-local responsible bidder, then the purchase award shall be awarded to the local responsible bidder. In the event that a non-local responsible bidder and a local responsible bidder have the same bid and it is the lowest bid, then the five percent (5%) preference need not be applied and the local business shall be selected to receive the purchase award. Under no circumstances shall the local business preference granted in a single bid exceed \$5,000.00. The local business preference will not apply when bids are cooperatively solicited together with other public agencies. The local business preference may not apply and may be dispensed with when prohibited by State or Federal Statutes, or regulations requiring that a bid be awarded to the lowest responsible bidder, or as otherwise exempted from local preferences.

##### **Good Faith Effort**

All contractors who submit bids or proposals to construct or provide work on any City of Atwater Public Works Project, or for any other Public Works construction or improvement on City property, and who are seeking a local business preference, must make a good-faith effort to hire qualified individuals who are residents of the City of Atwater or Merced County in sufficient numbers so that no less than 50 percent (50%) of the contractor's total construction work force, including subcontractor work force, measured in labor work hours, is comprised of Atwater residents. This same requirement applies to all subcontractors.

Evidence of direct bid solicitations from at least three Local Businesses qualified to perform the work or supply the materials or equipment must be submitted for subcontracted work in excess of one half of one percent (½ of 1% or 0.5%) of the trade package amount. If no Local Businesses are qualified to perform the work or supply the materials or equipment, justification and evidence of reasonable attempts to locate qualified Local Businesses must be submitted, which may include, but is not limited to: 1) advertisements inviting bids or recruitment of local, qualified individuals in local newspapers, or 2) mail request for bids to local contractors, or 3) bid solicitations by phone, facsimile, or e-mail, or 4) advertisement or contact of recruitment sources to hire local, qualified individuals., or 5) identify local, qualified individuals that are part of the contractor's or subcontractor's construction workforce, or 6) develop a written plan to recruit local residents as part of the construction workforce

### **Quality and Fitness**

The preferences established in this program shall in no way be construed to inhibit, limit or restrict the right and obligation of the City of Atwater to compare quality and fitness for use of supplies, materials, equipment, and services proposed for purchase and to compare the qualifications, character, responsibility, and fitness of all persons, firms, or corporations submitting bids.

### **Local Business Eligibility**

For the purposes of this program, a qualified local bidder is defined as any individual, partnership, or corporation which regularly maintains a place of business within the incorporated city limits of the City of Atwater and has a valid business license issued by the City of Atwater when the bid is provided. A non-local bidder shall be all others which may do business with the City of Atwater.

### **Enforcement**

The information furnished by each bidder establishing a good faith effort to solicit Local Businesses shall be under penalty of perjury. No person or business shall willfully and knowingly make a false statement with the intent to defraud, whether by affidavit, report, or other representation for the purpose of influencing the status of any entity as a Local Business.

## **Replace the entirety of section 3-1.18 with:**

### **3-1.18 CONTRACT EXECUTION**

The successful bidder must sign the *Contract* form.

Deliver to the contact listed in the *Notice to Bidders*:

1. Signed Contract form
2. Contract bonds
3. Certificates of insurance as identified in section 3-1.07
4. Evidence that you possess a current, valid California Contractor's license required to perform the Work under this Contract. A copy of your license is sufficient.

The City must receive these documents before the 5th business day after the bidder receives the contract.

The bidder's security may be forfeited for failure to execute the contract within the time specified (Pub Cont Code §§ 10181, 10182, and 10183).

A sample *Contract* form is included in the *Bid Book*.

## 5 CONTROL OF WORK

### Replace the entirety of Section 5-1.09:

The City of Atwater encourages mutual cooperation between the City, the Contractor and all project stakeholders. Compliance with Caltrans professionally facilitated project partnering is not required for this project.

### Add to the end of section 5-1.20B(1) General:

The Contractor may be given a no-cost extension of time for unforeseen delays attributable to the permit.

### Replace section 5-1.20E with:

#### 5-1.20E Water Meter Charges

The City can provide construction water for a fee. The Fiscal Year 2024-25 costs for construction water supplied from fire hydrants, per City Council Resolution 3400-23, are as follows:

1. Meter Deposit: \$547.00 (refundable);
2. Meter Installation: \$46.00;
3. Water Usage: \$5.00 per 1,000 gallons.

Fees may increase Contractor may obtain an application for a hydrant meter from the Finance Department.

### Replace the entirety of Section 5-1.23 Submittals with:

#### SECTION 5-1.23 SUBMITTALS

##### A. General

Submittals covered by these requirements include manufacturers' information, shop drawings, test procedures, test results, samples, requests for substitutions, and miscellaneous work-related submittals. The Contractor shall furnish all drawings, specifications, descriptive data, certificates, samples, tests, methods, schedules, and manufacturer's installation and other instructions as specifically required in the Contract Documents to demonstrate fully that the materials and equipment to be furnished and the methods of work comply with the provisions and intent of the Contract Documents.

##### B. Contractor Responsibilities

1. The Contractor shall be responsible for the accuracy and completeness of the information contained in each submittal and shall assure that the material, equipment or method of work shall be as described in the submittal. The Contractor shall verify that all features of all products conform to the specified requirements. Submittal documents shall be clearly edited to indicate only those items, models, or series of equipment, which are being submitted for review. All extraneous materials shall be crossed out or otherwise obliterated. The Contractor shall ensure that there is no conflict with other submittals and notify the Engineer in each case where his submittal may affect the work of another contractor or the City. The Contractor shall coordinate submittals among his subcontractors and suppliers including those submittals complying with unit responsibility requirements specified in applicable technical sections.

2. The Contractor shall coordinate submittals with the work so that work will not be delayed. The Contractor shall coordinate and schedule different categories of submittals, so that one will not be delayed for lack of coordination with another. No extension of time will be allowed because of failure to properly schedule submittals. The Contractor shall not proceed with work related to a submittal until the submittal process is complete.
3. The Contractor shall certify on each submittal document that he has reviewed the submittal, verified field conditions, and complied with the Contract Documents.

C. Transmittal Procedure

1. Unless otherwise specified, submittals regarding material and equipment shall be accompanied by Transmittal Form. A separate form shall be used for each specific item, class of material, equipment, and items specified in separate, discrete sections, for which the submittal is required. Submittal documents common to more than one piece of equipment shall be identified with all the appropriate equipment numbers. Submittals for various items shall be made with a single form when the items taken together constitute a manufacturer's package or are so functionally related that expediency indicates checking or review of the group or package as a whole.
2. If the Contractor proposes to provide material, equipment, or method of work which deviates from the project requirements, he shall indicate so under "deviations" on the transmittal form accompanying the submittal copies.
3. If specified or agreed to by the Engineer, electronic submittals may be made in Adobe PDF electronic file format. File resolution must be at least 300 dpi. Each email attachment must not exceed 25 MB in size and the total size of any email message must not exceed 50 MB. Size limits are subject to change based on the policies of the City's use of technology policies and limits. If separate emails are needed to accommodate large files indicate the total number of emails included in the submittal. After submitting electronic files, send a notification of the electronic submittal to the Engineer, including the names of the submitted files. Upon completion of review, the City will return one (1) or more electronic copy, depending on the number of reviewers required.

D. Submittal Review Procedure

1. Review shall not extend to means, methods, techniques, sequences or procedures of construction. Verifying quantities, dimensions, weights or gages, or fabrication processes (except where specifically indicated or required by the project) or to safety precautions or programs incident thereto. Review of a separate item, as such, will not indicate approval of the assembly in which the item functions.
2. Seven copies, unless otherwise specified during the preconstruction meeting, of all submittals required shall be furnished to the Engineer for review. The Engineer shall review the submittal and return two copies of the marked-up original within 15 working days after receipt of a submittal for review and comment, unless otherwise specified. All shop drawings and layout drawings submittals shall be submitted a minimum of 20 working days before approved submittal drawings will be required for the work.
3. Submittals which do not have all the information required to be submitted, including deviations, are not acceptable and will be returned without review.

E. Effect of Review of Contractor's Submittals

1. Review of contract drawings, methods of work, or information regarding materials or equipment the Contractor proposes to provide, shall not relieve the Contractor of his responsibility for errors therein and shall not be regarded as an assumption of risks or liability by the Engineer or the City, or by any employee thereof, and the Contractor shall have no claim under the Contract on account of the failure, or partial failure, of the method of work, material, or equipment so reviewed.
2. The Work covered by a submittal may be commenced only after the Engineer has reviewed the pertinent submittals and returned copies to the Contractor marked either "No Exceptions Taken" or "Make Corrections Noted." Corrections indicated on submittals shall be considered as changes necessary to meet the requirements of the Contract Documents. Review of submittals by the Engineer shall not be construed as relieving the Contractor of his/her responsibilities under this Contract.

**Replace the entirety of Section 5-1.24 CONSTRUCTION SURVEYS with:**

The City of Atwater will furnish construction staking to execute the work. The Contractor shall make timely requests to the City for such staking on a form to be provided by the City. A written notice of not less than three working days will be required in advance of setting stakes. Preserve construction stakes, reference points, and other survey points. In case of their loss or destruction, the Contractor shall be liable for and charged with the cost of their replacement and for any expense resulting from their loss or disturbance. Such costs may be deducted from amount due Contractor. Do not proceed with the work that requires construction staking until construction stakes have been provided.

**Replace the entirety of Section 5-1.25 with:**

**Section 5-1.25 SURVEY MONUMENT PRESERVATION**

The City shall be responsible to perpetuate and/or reset survey monuments that may be damaged or disturbed during construction in compliance with all applicable requirements of Section 8771 (a-f) of the California Business and Professions Code. However, Contractor shall be responsible to carefully preserve survey monuments that have been exposed or located, and shall be responsible to bear all expenses for replacement due to unnecessary loss. Contractor shall also be responsible to adjust monument well covers to grade within the area of improvements.

All costs for compliance with this section shall be included in the unit costs for the various items of work, with no additional compensation provided therefor.

**Add before paragraph 1 of section 5-1.36(C)1:**

Notify Underground Service Alert (USA North) at least 48 hours prior to beginning any work involving cutting, planning, trenching or digging. Contractor shall notify USA North at 811 or 800-642-2444 with the specifics of the intended work on the job site. Contractor shall follow and comply with all USA policies and procedures. Contractor shall obtain a USA ticket number and wait for utilities to mark the location of underground utilities within the Project area, or for USA to advise Contractor of the absence of underground utilities in the Project area. Contractor shall provide Engineer with USA ticket number and provide him/her the opportunity to review all utility markings prior to beginning any work.

## **7 LEGAL RELATIONS AND RESPONSIBILITY TO THE PUBLIC**

**Replace paragraph 2 of section 7-1.02K(2) with:**

The general prevailing wage rates determined by the Director of Industrial Relations, for the county or counties in which the work is to be done, are available at the California Department of Industrial Relations' Internet Web Site at: <https://www.dir.ca.gov/OPRL/DPreWageDetermination.htm>. These wage rates are

not included in the Bid Book for the project. Changes in general prevailing wage determinations apply to the Contract when the Director of Industrial Relations has issued them at least 10 days before advertisement. (Labor Code § 1773.6 and 8 CA Code of Regs 16204).

**Add to section 7-1.02K(2):**

All labor will be paid at not less than the minimum wage rates established by the State of California's Director of Industrial Relations (State Wage Rates). The minimum Federal Wage Rates, if applicable to this project, are included in and/or attached by reference to the book issued for bidding purposes entitled "Bid Book".

**Replace paragraph 5 of section 7-1.02K(3) with:**

You may submit certified payroll records electronically to the City of Atwater by emailing records to [jvinson@atwater.org](mailto:jvinson@atwater.org).

**Replace paragraph 1 of section 7-1.02K(6)(j)(ii) with:**

Section 7-1.02K(6)(j)(ii) applies to this project and is included in Bid Item 4.

**Add to the end of section 7-1.04:**

Do not reduce an open traffic lane width to less than 10 feet, unless otherwise shown on approved temporary traffic control plans.

**Add before paragraph 1 of section 7-1.05A:**

You must defend, indemnify, and hold harmless the City, its elected and appointed councils, boards, commissions, officers, employees, agents, volunteers, representatives, and design professionals from and against any and all claims, lawsuits, actions, liabilities, damages, losses, expenses, costs, and actual attorneys' fees, arising out of or in connection with your performance of this Contract for:

1. any loss or damage that may happen to the work or any part thereof; and
2. for any loss or damage to any of the materials, equipment, tools, or other things used or employed in performing the work; and
3. for injury to or death of any person, either workers or the public; and
4. for damage to property from any cause which might have been prevented by the Contractor, or his/her workers, or anyone employed or subcontracted by him/her.

For purposes of your obligation to defend, indemnify, and save harmless, the term State will have the following meaning: The City of Atwater including its elected and appointed councils, boards, commissions, officers, employees, agents, volunteers, representatives, and design professionals.

**Change the "Umbrella or excess liability" limits in the table titled "Liability Limits" in paragraph 1 of section 7-1.06D(2) to:**

\$2,000,000.

**Replace section 7-1.06G with:**

At the option of the City, either: The insurer will reduce or eliminate such deductible or self-insured retentions as respects to the City of Atwater, its officers, directors, agents, and employees; or the Contractor will procure a bond guaranteeing payment of losses and related investigation, claim administration and defense expenses.

**Add to section 7-1.06H:**

Any failure to comply with reporting provisions of the policies will not affect coverage provided to the City of Atwater, its officers, directors, agents, and employees.

**8 PROSECUTION AND PROGRESS**

**Remove paragraphs 1 and 2 in section 8-1.04B**

**9 PAYMENT**

**Add to section 9-1.03:**

The agency shall hold retainage from the prime contractor and shall make prompt and regular incremental acceptances of portions, as determined by the agency, of the contract work, and pay retainage to the prime contractor based on these acceptances. The prime contractor, or subcontractor, shall return all monies withheld in retention from a subcontractor within 30 days after receiving payment for work satisfactorily completed and accepted including incremental acceptances of portions of the contract work by the agency. Federal law (49CFR26.29) requires that any delay or postponement of payment over 30 days may take place only for good cause and with the agency's prior written approval. Any violation of this provision shall subject the violating prime contractor or subcontractor to the penalties, sanctions and other remedies specified in Section 7108.5 of the Business and Professions Code. These requirements shall not be construed to limit or impair any contractual, administrative, or judicial remedies otherwise available to the prime contractor or subcontractor in the event of a dispute involving late payment or nonpayment by the prime contractor, deficient subcontract performance, or noncompliance by a subcontractor.

**Replace "Department" in paragraphs 3, 4 and 5 of section 9-1.07A with:**

Caltrans

**Delete section 9-1.11**

**Add to section 9-1.16E(1):**

The bid amount for the contract items of work is the maximum value the City recognizes for progress payment purposes unless approved change order work increases this amount.

**Replace section 9-1.16F with:**

The City withholds five percent (5%) of all progress payments as retention. Retention will be paid to you with Final Payment.

You have the right to substitute securities for retention under Public Contract Code § 22300. No substitution will be accepted until:

1. the City approves the securities and their value; and
2. the parties have entered into an escrow agreement (if the securities are to be held in escrow) in a form substantially similar to that under § 22300; and
3. all documentation necessary for assignment of the securities to the City or to the escrow agent, are delivered in a form satisfactory to the City.

If you substitute securities for any portion of the retention, the City may request that such securities be revalued from time to time, but not more often than monthly. Such revaluation will be made by a person or

entity designated by the City and approved by you. If such revaluation results in a determination that the securities have a market value less than the amount of retention for which they were substituted, then the amount of the retention required under the Contract will be increased by such difference in market value. Such increased retention will be withheld from the next progress payment(s) due to you under the Contract.

**Replace section 9-1.22 with:**

Claims must be litigated in a court of competent jurisdiction.

## **DIVISION II GENERAL CONSTRUCTION**

### **12 TEMPORARY TRAFFIC CONTROL**

#### **Add the following to section 12-1.01:**

Not later than the preconstruction conference, submit a traffic control plan for acceptance by the Engineer. The plan shall detail all measures to be taken to maintain traffic and control access through the area of work and maintain access to adjacent properties during construction.

The traffic control plan shall depict the traffic handling equipment and devices to be used and their location. It shall detail lane closures, pedestrian detours, and temporary pavement delineations necessary to complete the work as shown on the plans.

Costs for developing and implementing the traffic control plan are to be included in the various bid items with no additional payment due therefor.

#### **Add to the end of section 12-4.01A:**

The full width of the traveled way must be open to traffic on:

- Friday after 3:00 p.m.
- Saturday
- Sunday
- Designated holidays
- Martin Luther King Jr. Day, Cesar Chavez Day, Good Friday, and the Friday after Thanksgiving.

Personal vehicles of contractor's employees must not be parked on the traveled way or shoulders, including sections closed to traffic.

### **13 WATER POLLUTION CONTROL**

#### **Replace Section 13-1.01A Summary in its entirety with:**

##### **13-1.01A Summary**

This project is anticipated to result in a total land disturbance area less than one (1) acre and is therefore not subject to the State of California's National Pollutant Discharge Elimination System (NPDES) General Permit for Storm Water Discharges Associated with Construction and Land Disturbance Activities (CAS000002, Order No. 2022-0057-DWQ). Preparation of a SWPPP and processing of Permit Registration Documents with the State's Water Board are not required for this project.

Contractor will be required to prepare and implement a Water Pollution Control Program (WPCP) as a submittal prior to construction. The WPCP shall include, at a minimum:

1. Drawing(s) showing location and type of BMP's proposed for the project;
2. Details or fact sheets of proposed BMP's;
3. Emergency contact information for contractor and subcontractors; and
4. Inspection procedures indicating frequency of required inspections.

Contractor is required to continuously exercise good housekeeping and job site management to prevent sediment transport and stormwater pollution.

Costs for preparation and implementing the WPCP are included in the bid item for "Erosion, Sedimentation, and Pollution Control", and no additional payment will be provided therefor. The bid item includes installation and implementation of Best Management Practices (BMPs) required to prevent sedimentation and pollution discharge to storm drains including, but not limited to, inlet protection devices, street sweeping, washout management, and/or other means necessary to prevent polluted discharge to storm drains.

**Remove sections 13-1.01C and 13-1.01D in their entirety.**

**Remove section 13-2 WATER POLLUTION CONTROL PROGRAM in its entirety.**

**Remove Section 13-3 STORMWATER POLLUTION PREVENTION PLAN in its entirety.**

## **14 ENVIRONMENTAL STEWARDSHIP**

**Replace paragraph 2 of section 14-8.02 with:**

Do not operate construction equipment or run the equipment engines from 7:00 pm to 7:00 am or on Sundays, except you may operate equipment within the project limits during these hours to:

1. Service traffic control facilities; or
2. Service construction equipment.

Should you feel it necessary to operate equipment or run equipment engines between 7:00 pm and 7:00 am or on Sundays, submit a request to the Engineer three working days in advance for review and approval. If the Engineer approves the request for work between these times, the Contractor will be responsible for payment of the additional inspection costs incurred by the City to make available an inspector during non-working hours. Additionally, work shall not exceed 86 dBA LMax at 50 feet from the job site activities from 7:00 pm to 7:00 am, unless authorized by the Engineer.

**Add to section 14-9.02:**

Fugitive dust control at the Project site is the sole responsibility of the Contractor. Dust control shall conform to all requirements set forth in the San Joaquin Valley Air Pollution Control District (SJVAPCD) Construction Notification Form, Regulation VIII, and Fugitive PM10 Prohibitions, as applicable, as well as the provisions in Section 14-9, "Air Quality" of the Caltrans Specifications and these Special Provisions.

The Contractor shall conduct and cause all working forces at the site to maintain the site in a neat, orderly manner throughout the construction operations. The work shall be conducted in a manner that will control dust, including compliance with Visible Dust Emissions (VDE) limits, maintaining Soil Stabilization at all times, management and cleanup of Carryout and Trackout, and management of Unpaved Access and Haul Roads, Storage Piles and Bulk Materials, and all Demolition Activities. When ordered to provide dust control, the Contractor shall use water to reduce the dusty conditions all to the satisfaction of the Engineer. Street sweeping or roadway cleaning activities shall be completed with PM10-efficient street sweepers. During construction, the Contractor shall remove all rubbish and debris as it is generated. Upon completion of the work, the Contractor shall remove all equipment and debris, and shall leave the site in a neat, clean condition all to the satisfaction of the Engineer.

Water for the purpose of dust control shall be potable. All dust control operations shall be performed by the Contractor at the time, location and in the amount ordered by the Engineer. The application of either water or dust palliative shall be under the control of the Engineer at all times. Watering shall conform to the

provisions of Section 13 "Water Pollution Control" of the Caltrans Specifications and these Special Provisions. Attention is also directed to Section 18 "Dust Palliatives" of the Caltrans Specifications and these Special Provisions.

The Contractor is responsible for obtaining construction water.

## **15 EXISTING FACILITIES**

### **Add to the end of paragraph 1 of section 15-1.01:**

This section also includes general specifications for removal and/or demolition of items called for in the plans, specifications, and scope of work.

### **Replace section 15-1.03c with:**

Where existing items are called for in the plans, specifications, or scope of work to be salvaged or remanded to the owner, make reasonable efforts to contact private owners to determine particulars of delivery of salvaged materials. Deliver and store salvaged materials to owners in a neat, organized manner, or dispose of if specifically directed to do so by owners.

All items designated to be returned to the City shall be delivered to the Public Works Department Corporation Yard at 470 Aviator Drive, Atwater, CA 95301. Coordinate with the City's Project Manager at least two (2) working days prior to any delivery.

### **Replace section 15-1.04 with:**

Bid items for removal of existing features include all costs for removal and off-haul of said items or remanding them to owner if called for on the plans. Payment will be based on measured quantities and units indicated in the bid item list, with no additional payment made therefor. Costs for removal or demolition of items required to perform the work that are not specifically included in removal bid items are to be included in the other various items of work, with no additional payment made therefor.

## **DIVISION III EARTHWORK AND LANDSCAPING**

### **17 GENERAL**

#### **Replace paragraph 4 of section 17-2.03A with:**

Clear and grub the entire job site as required where pavements, pavement overlays, curbs, gutters, sidewalks, and retaining curbs are to be constructed, and within the slope lines of any excavations and embankment slopes.

#### **Replace section 17-2.04 with:**

Costs for compliance with this section, as well as all other required surface preparation and demolition work not specifically included in other bid items, is to be included in the various bid items of work, with no additional payment provided therefor.

## DIVISION IV SUBBASES AND BASES

### 23 GENERAL

#### **Replace section 23-1.01D(1)(b) with:**

You and the Engineer must work together to avoid potential conflicts and to resolve disputes regarding test result discrepancies. Notify the Engineer within 5 business days of receiving the test result if you dispute the test result.

If you or the Engineer dispute each other's test results, submit your test results and copies of paperwork including worksheets used to determine the disputed test results. An independent third party performs referee testing. Before the independent third party participates in a dispute resolution, it must be qualified under AASHTO resource program and Caltrans' Independent Assurance Program. The independent third party must have no prior direct involvement with this Contract. By mutual agreement, the independent third party is chosen from:

1. Caltrans laboratory in a district or region not in the district or region the project is located
2. METS
3. Laboratory not currently employed by you or your material producer

If split acceptance samples are not available, the independent third party uses any available material representing the disputed material for evaluation.

If the independent third party determines the City's test results are valid, the Engineer deducts the independent third-party testing costs from payments. If the independent third party determines your test results are valid, the City pays the independent third-party testing costs.

## DIVISION V SURFACINGS AND PAVEMENTS

### 37 SEAL COATS

#### **Replace paragraph 1 of section 37-6.03 with:**

Treat cracks from 1/4 to 1 inch in width for the entire length of the crack. Fill or repair cracks wider than 1 inch with Hot Mix Asphalt.

#### **Replace 37-6.04 with:**

The payment quantity for crack treatment is the area of existing pavement, measured in square feet to be treated, and is included in Bid Item 6.

### 39 ASPHALT CONCRETE

#### **Replace numbered line 1 in paragraph 2 of section 39-2.01C(3)(g) with:**

1. Repair cracks 1/4 inch and wider, spalls, and holes in the pavement. This work is included in the bid item "Repair Existing Pavement" and no additional payment will be made therefor.

#### **Remove paragraphs 3 and 4 and replace the first sentence in paragraph 4 of section 39-2.01C(4)(a) with:**

You must place HMA on adjacent traveled way lanes such that at the end of each work shift, the distance between the ends of HMA layers on adjacent lanes is from 5 to 10 feet.

#### **Replace paragraphs 1 and 2 of section 39-2.01(D) with:**

Payment for geosynthetic pavement interlayer, tack coat, asphalt binder, and asphaltic emulsion is included in the payment for HMA bid items.

#### **Replace paragraph 5 of section 39-2.01(D) with:**

The payment quantity for HMA of the type and thickness shown on the bid item list is the area of installed HMA measured in square feet paved to the thickness indicated. Payment includes costs for materials, placement, and compaction with no additional payment made therefor.

#### **Add to section 39-2.02A(1):**

Use one-half-inch (1/2") maximum aggregate gradation unless otherwise specified or noted in the plans. Use PG64-10 asphalt binder.

#### **Replace section 39-2.02B(3) with:**

The grade of asphalt binder for Type A HMA must be PG 64-10.

**Replace section 39-2.06D with:**

Bid item cost for HMA Overlay includes costs for placement and compaction of HMA in areas where asphalt pavement replacement or installation is called for in the plans, specifications, or scope of work. The payment quantity for HMA is the area of installed HMA, measured in square feet, paved to the thickness indicated in the bid item list, with no additional payment made therefor. No additional payment will be provided for pavement that is installed in thicknesses greater than called for in the plans, specifications, scope of work, and bid documents without prior authorization from the Engineer.

**Replace section 39-3.01D with:**

Bid item cost for “Remove Existing AC Pavement” includes all costs associated with cutting and removal of existing asphalt pavement as shown in the plans, including compliance with section 39-3.

**Replace section 39-3.04D with:**

Bid item cost for “Remove Existing AC Pavement (Wedge Grind)” includes all costs associated with cold planing asphalt concrete pavement as shown or described in the plans, specifications, and scope of work. The payment quantity is lineal feet of actual length cold planed in a wedge grind to the width and depth described in the bid item and shown on the plans.

## **DIVISION VIII MISCELLANEOUS CONSTRUCTION**

### **77 LOCAL INFRASTRUCTURE**

#### **Replace Section 77-1 with:**

##### **77-1 UTILITY RELOCATION**

###### **77-1.01 GENERAL**

This project will include adjustments to finish grade of existing utility structure rims, frames, and covers. Existing “dry” utility structures including electrical, gas, cable television, and telephone structures will be adjusted to grade by the respective utility companies. The Contractor will prepare applications for adjustment to grade of these structures with the utility companies. Contractor is required to coordinate work as necessary to allow for the adjustment to grade prior to placement of HMA. The City of Atwater will pay fees due the utility companies necessary for the adjustments of their facilities to finish grade.

No additional compensation, including Time Related Overhead, will be paid as a result of delays by the utility companies in adjusting existing structures to grade. Additional working days may be granted in the event of delays caused by the utility companies. Any incidental costs associated with adjusting the existing dry utility structures to grade are to be included in the various bid items of work, and no additional payment will be provided therefor.

Contractor will be responsible for adjustment of existing “wet” utility structures as indicated on the plans, including storm drain manholes, sanitary sewer manholes, and water valve covers. Wet utility structure rims will be adjusted to grade in accordance with City standard details. Costs for adjustment of the existing sanitary sewer manhole is to be included in the bid item for “Raise Existing Utilities Covers to Finish Grade”.

## **DIVISION IX TRAFFIC CONTROL DEVICES**

### **84 MARKINGS**

#### **Replace section 84-1.02 with:**

Materials for the bid item "Replace Traffic Striping and Pavement Markings" shall be retroreflective thermoplastic per section 84-2.02C with glass beads per section 84-2.02B and shall consist of replacement traffic stripes and pavement markings per details of the current Caltrans Standard Plans and California MUTCD to match function of existing markings, with no additional payment made therefor.

#### **Replace section 84-2.04 with:**

Payment shall be lump sum for the bid item "Replace Traffic Striping and Pavement Markings" and shall include all costs for replacement traffic stripes and pavement markings per details of the current Caltrans Standard Plans and California MUTCD to match function of existing markings, with no additional payment made therefor.

## **DIVISION XI MATERIALS**

### **96 GEOSYNTHETICS**

#### **Add to paragraph 1 of section 96-1.02J:**

Paving fabric shall be PETROMAT® 4598 or approved equal.

May 05, 2025

## ADDENDUM No. 1

PROJECT: **OLIVE AVENUE OVERLAY**

**BID CALL NO. 733-25; PROJECT NO. 24-07**

Addendum No. 1 is being issued to the Notice to Bidders, Specifications and Plans, for the **Olive Avenue Overlay Project**. Bids for this proposal are to be opened on **Thursday, May 15, 2025** at 2:00 P.M. in the City of Atwater Council Chamber, at 750 Bellevue Road, Atwater, CA 95301

The following responses address questions identified as Bid RFI Nos. 1 through 5, from all Bid RFIs received through 05/01/2025:

- BID RFI No.1:** *Are we allowed to download the documents from the City of Atwater website, and use those as official bidding documents which we will submit our proposal on? Or do we need to purchase official bid books from the City for \$50.00? If the documents are downloaded from the City website and are considered as official bidding docs., will be considered as an official planholder or is there another step I need to be considered as an official planholder?*

**Response: Yes, Bidders can use the electronic copies to bid. Bidders are not required to purchase a hardcopy set of plans and specifications. Send contact information to [jvinson@atwater.org](mailto:jvinson@atwater.org) to be put on the planholders list.**

- BID RFI No.2:** *What are the liquidated damages allocated to this project?*

**Response: Refer to Standard Specification Section 8-1.10A Liquidated Damages. Liquidated damages are \$3,600 per day.**

- BID RFI No.3:** *What is an approximate date the City is wanting this work to commerce?*

**Response: City anticipates work to begin between June-July 2025.**

- BID RFI No.4:** *I'd like to bid on the Olive Avenue Overlay(Project ID:202500176637). Could you let me know how I can move forward with the bid?*

**Response: Refer to Section 2 Bidding.**

5. **BID RFI No.5:** *Couldn't find a liquidated damages amount in the spec book. Do you guys have a number for that?*

**Response:** See response to BID RFI No.2.

**IF YOU SUBMIT A BID, A SIGNED COPY OF THIS ADDENDUM No. 1 MUST BE ATTACHED THERETO.**

Sincerely,

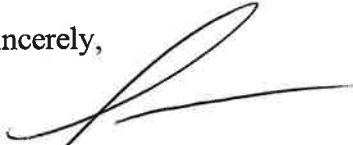

\_\_\_\_\_  
Justin Vinson  
Public Works Director  
Public Works Department

Contractor \_\_\_\_\_

Signature \_\_\_\_\_

Date \_\_\_\_\_

# **ATTACHMENT 2: PLANS**

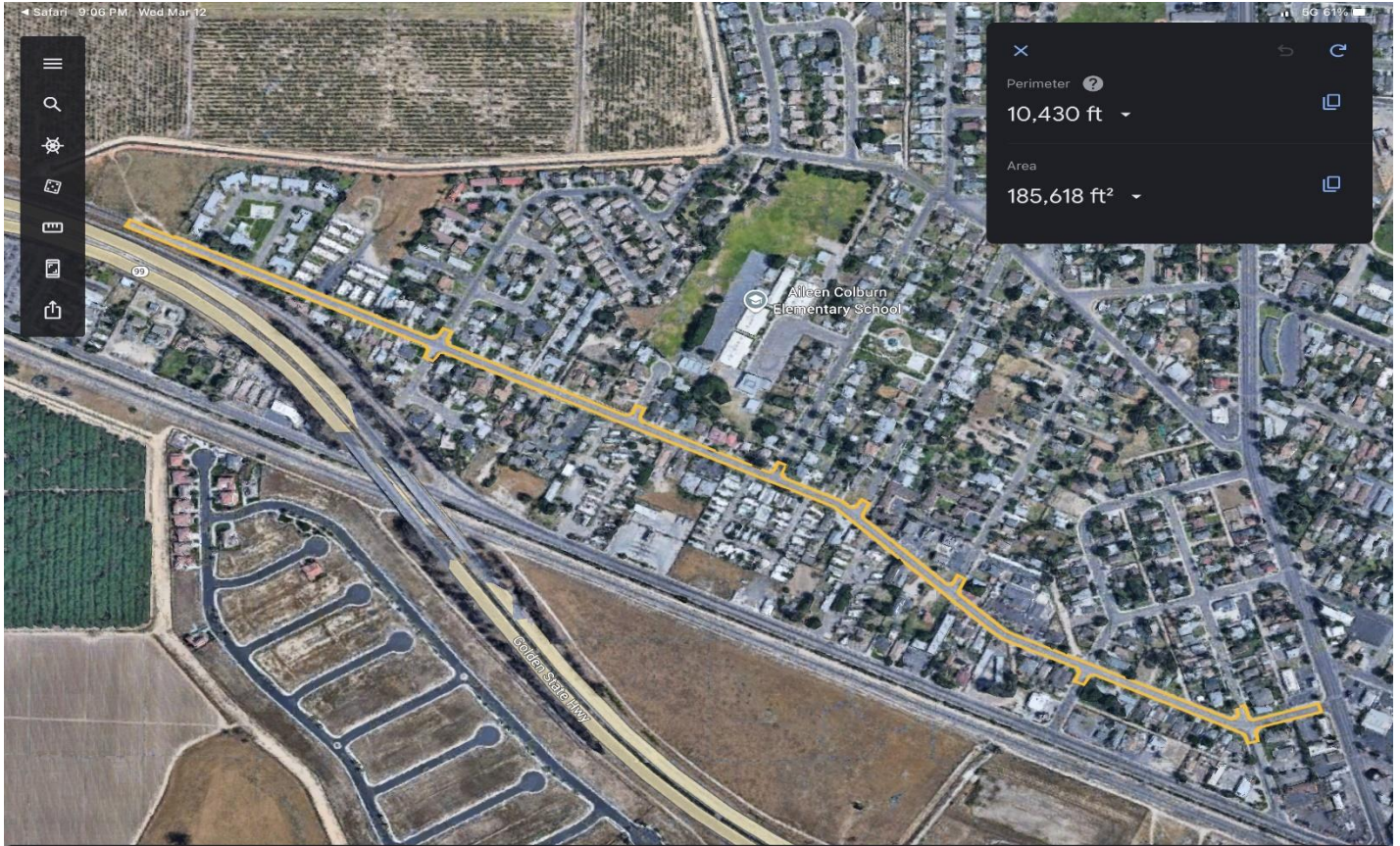

Perimeter 10,430 ft  
Area 185,618 ft<sup>2</sup>

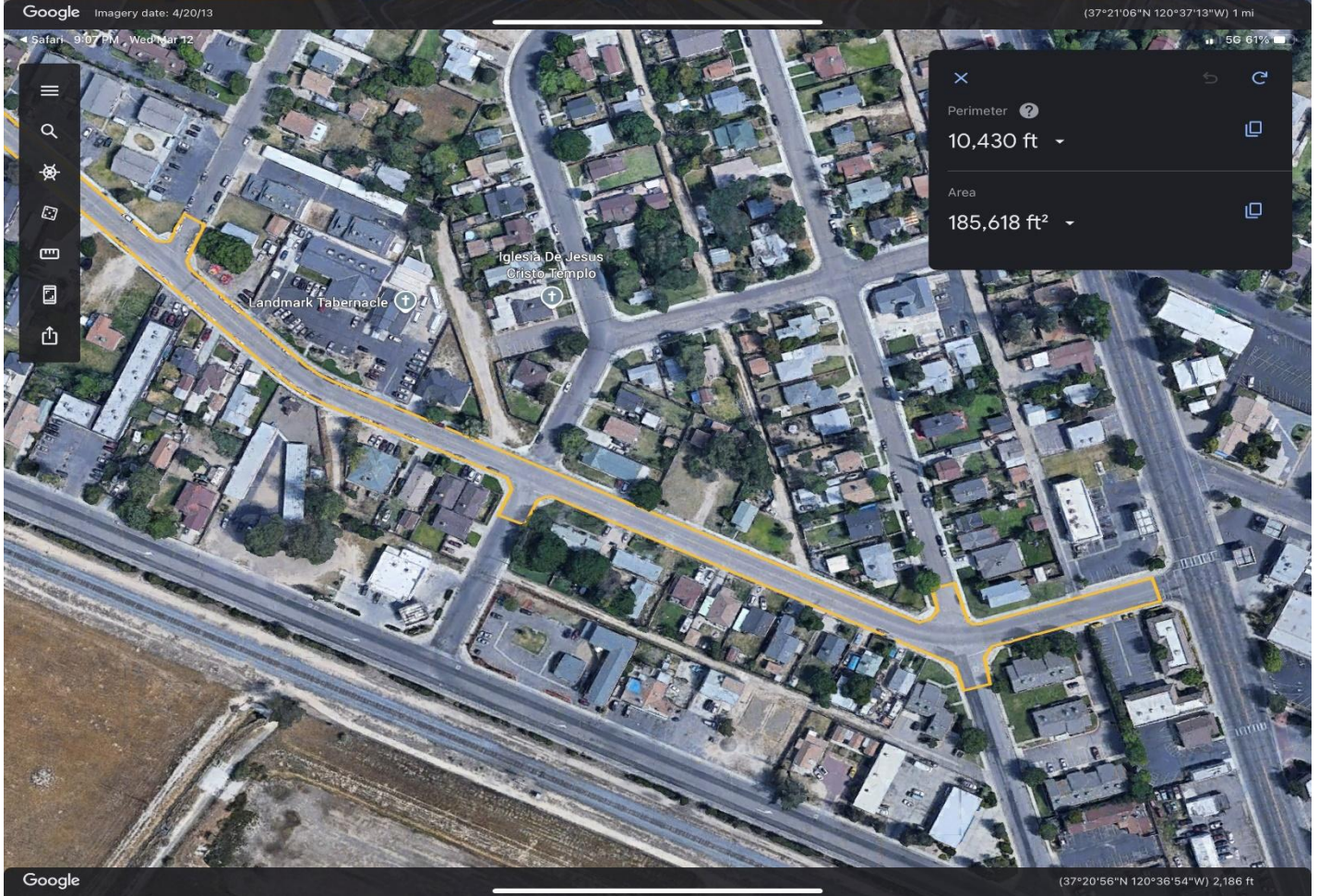

Perimeter 10,430 ft  
Area 185,618 ft<sup>2</sup>

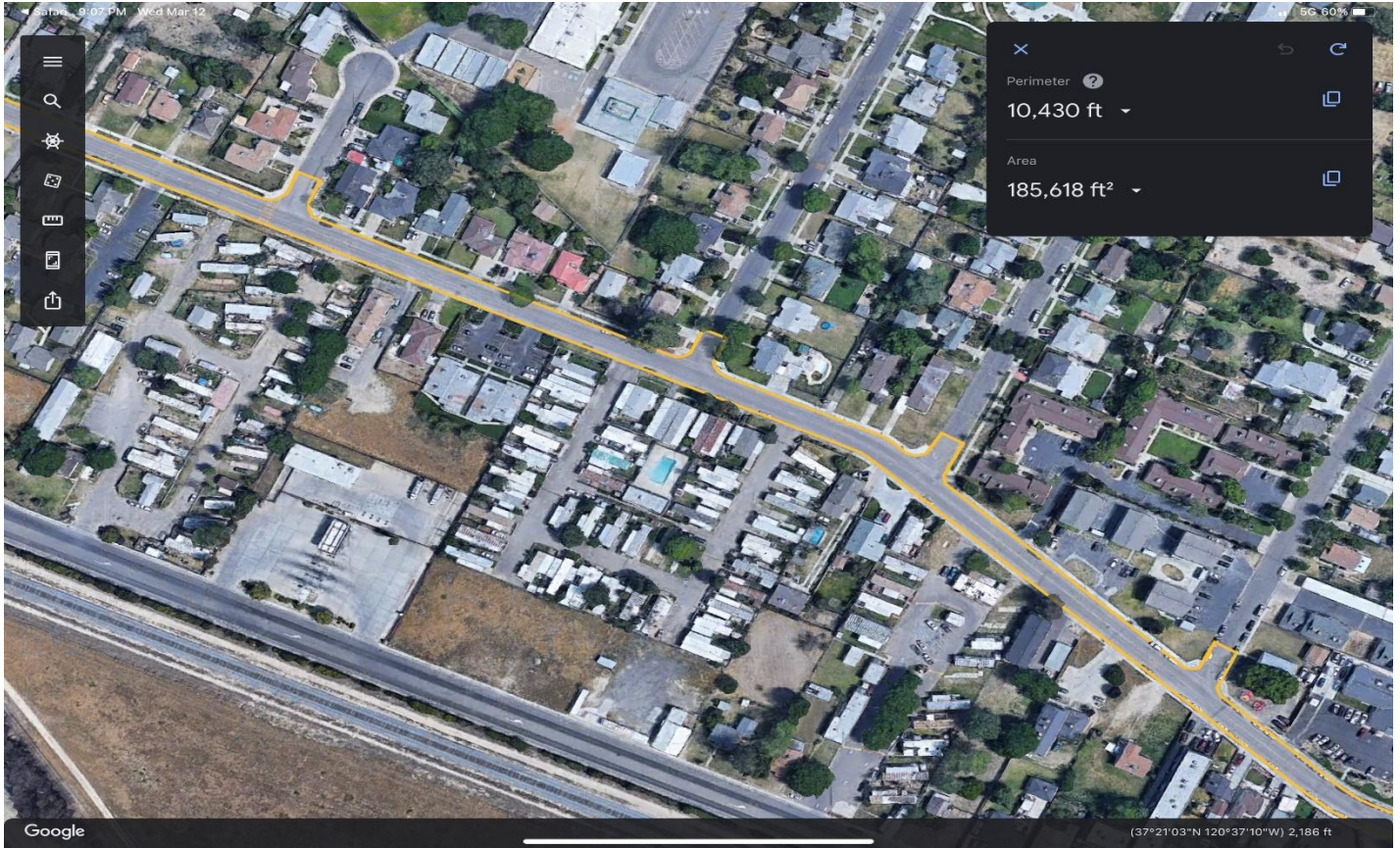

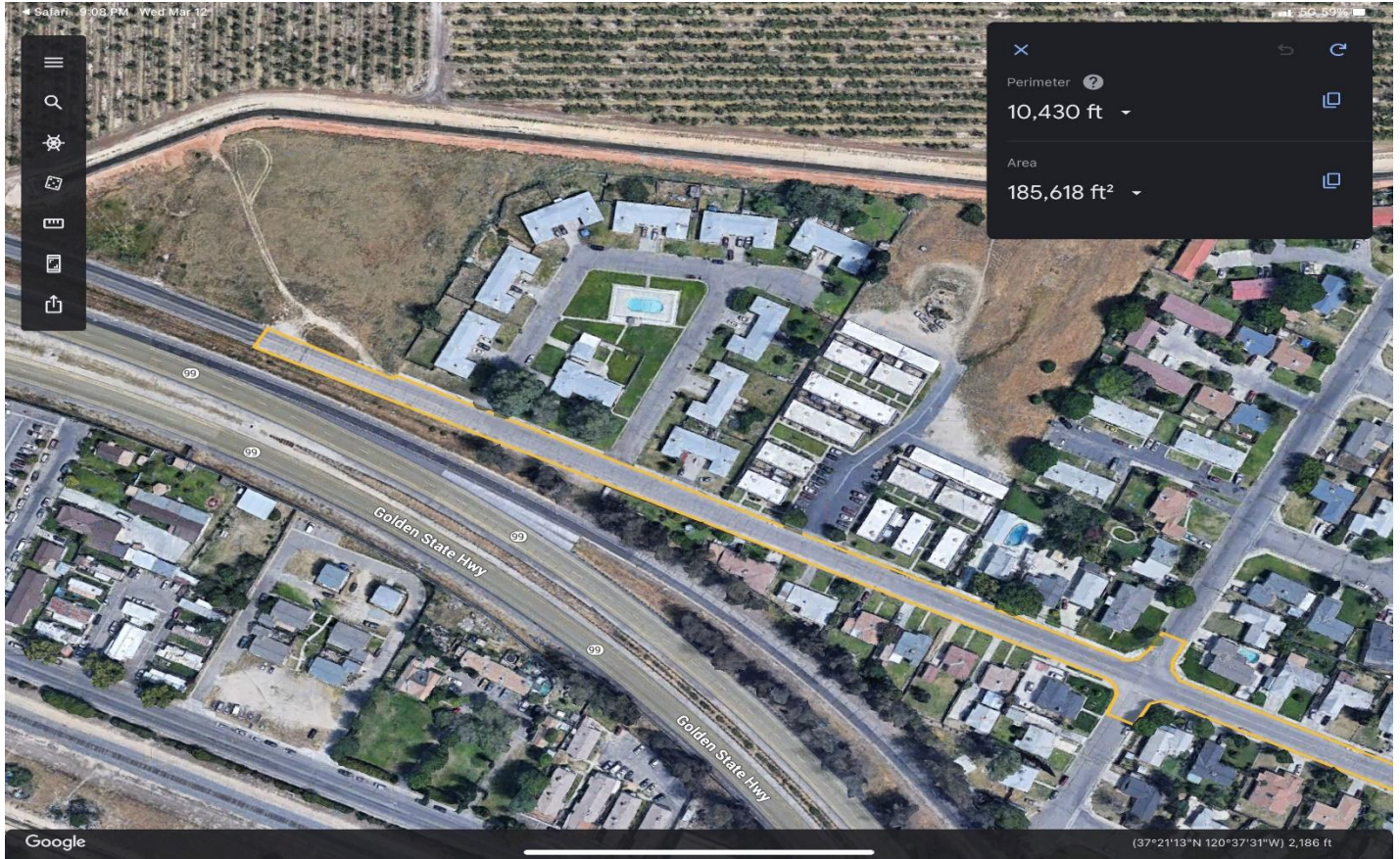

STEADY DEMAND SEQUENCE

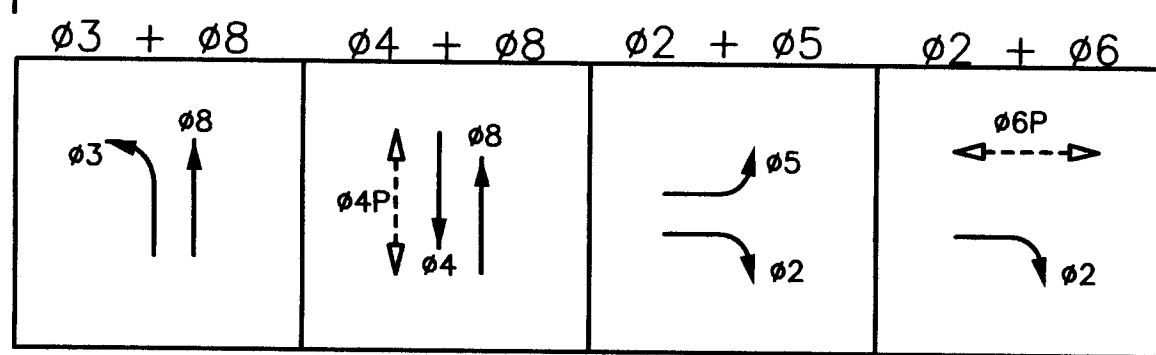

PROPOSED PHASE DIAGRAM

EMERGENCY VEHICLE PREEMPTION (EVP)

EVA = ø2 + ø5  
 EVB = ø4  
 EVD = ø3 + ø8

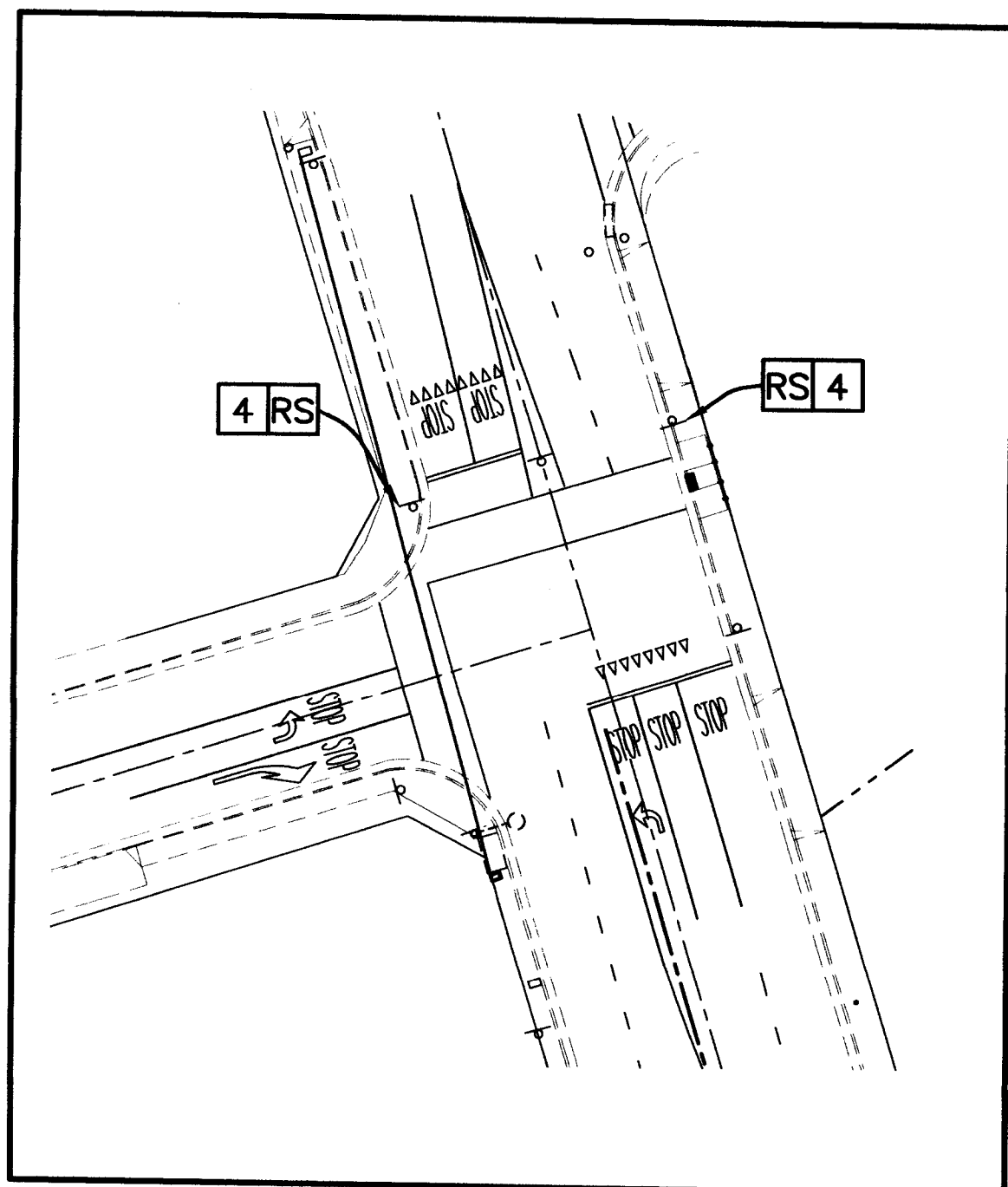

DEMOLITION PLAN  
 SCALE 1" = 40'

AS-BUILT

THIS PLAN SHEET CONFORMS OR HAS BEEN MODIFIED TO CONFORM TO AS-BUILT CONSTRUCTION CONDITION, AS PROVIDED BY THE CONSTRUCTION CONTRACTOR:

*Jose L. Benavides* DATE: 03/30/2023  
 JOSE LUIS BENAVIDES

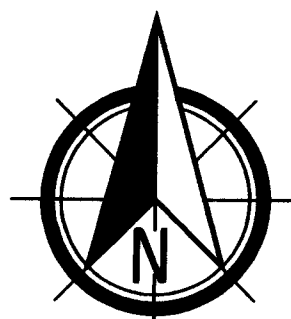

0 20' 40'  
 SCALE: 1"=20'

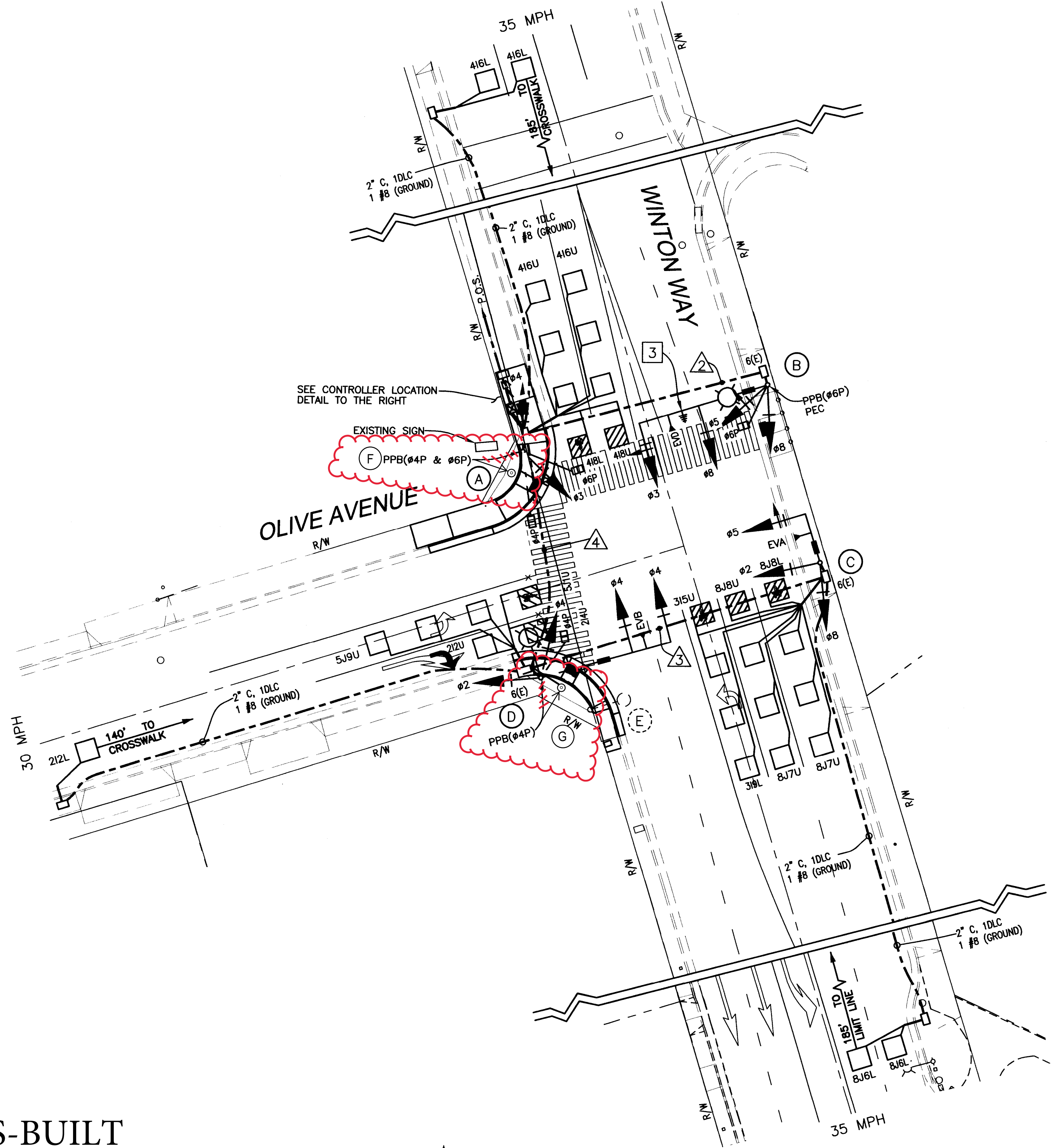

PROJECT NOTES (THIS SHEET ONLY):

- 1 FURNISH AND INSTALL TYPE 3 TIME CONTROLLER, NEW TYPE 332L CABINET WITH ALL ANCILLARY DEVICES FOR A FULL EIGHT PHASE OPERATION. FRONT SHALL FACE NORTH.
- 2 FURNISH AND INSTALL FOUNDATION AND NEW TESCO 26-100 LBS SERVICE CABINET. CONTRACTOR SHALL COORDINATE WITH PG&E FOR POINT OF SERVICE CONNECTION.
- 3 FURNISH AND INSTALL 300 MBPS, 5.180-5.825 GHZ SINGLE RADIO WITH INTEGRATED DUAL POLARITY PANEL ANTENNA WITH MOUNTING HARDWARE.
- 4 REMOVE AND SALVAGE IN-ROADWAY LIGHTING, PEDESTRIAN PUSH BUTTON POST, PUSH BUTTON, AND ALL SIGNS.
- 5 FURNISH AND INSTALL ETHERNET MODULE AND ONE GIGABIT SWITCH WITH MOUNTING HARDWARE IN THE CONTROLLER CABINET.
- 6 FURNISH AND INSTALL GPS TIME SOURCE MODULE & ANTENNA.

LEGEND:

- TYPE A RECTANGULAR LOOP DETECTOR CONFIGURATION PER STATE STANDARD PLAN ES-5B. LOOP SEALANT SHALL BE STATE APPROVED ELASTOMERIC SEALANT OR HOT MELT RUBBERIZED ASPHALT SEALANT.
- TYPE D RECTANGULAR LOOP DETECTOR CONFIGURATION PER STATE STANDARD PLAN ES-5B. LOOP SEALANT SHALL BE STATE APPROVED ELASTOMERIC SEALANT OR HOT MELT RUBBERIZED ASPHALT SEALANT.
- EMERGENCY VEHICLE PREEMPTION (EVP) DETECTION UNIT EVA (DENOTES CHANNEL)
- CA MUTCD COMPLIANT BICYCLE DETECTOR MARKING
- WIRELESS RADIO ANTENNA PER DETAILS ON SHEET 10

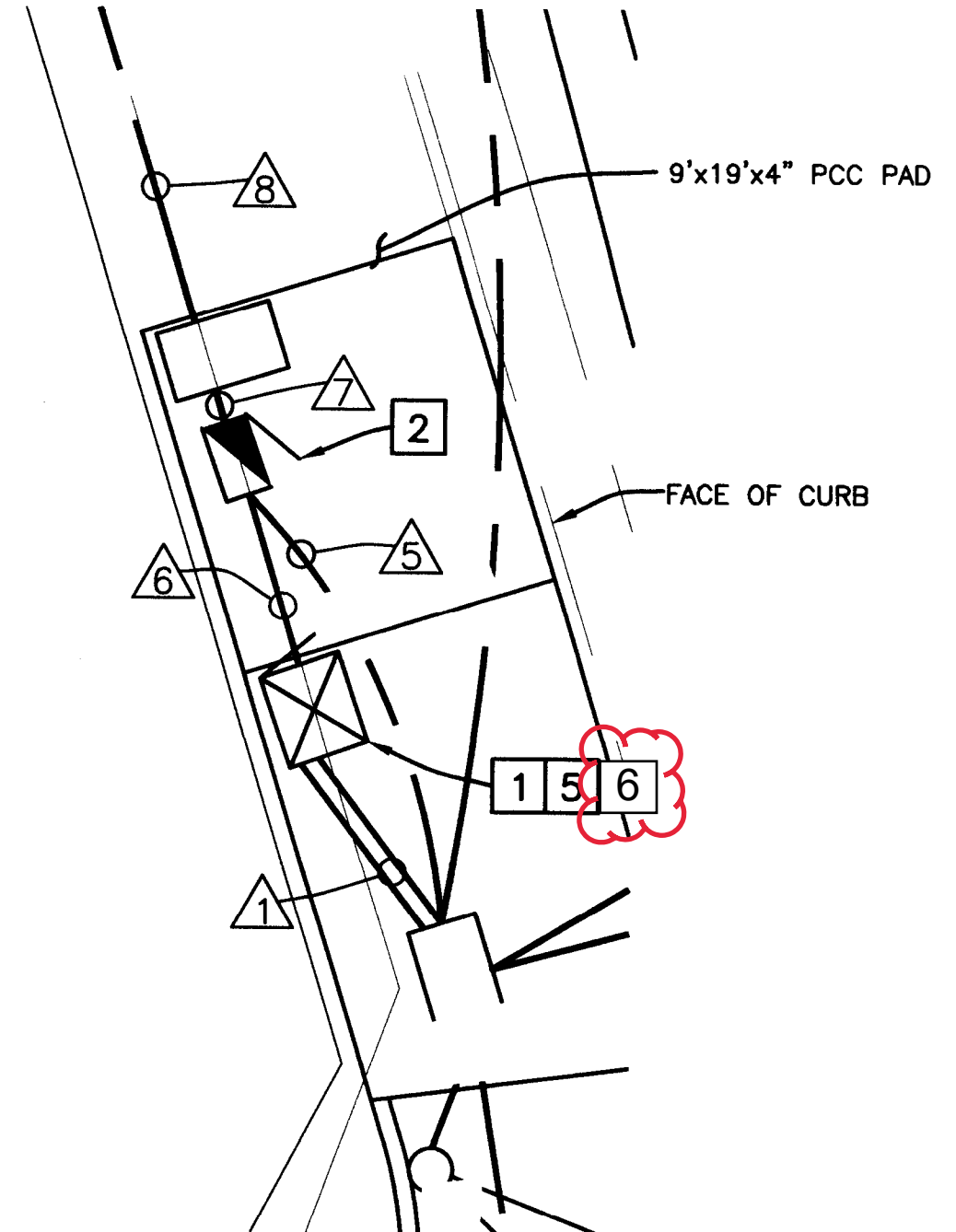

CONTROLLER LOCATION  
 NO SCALE

PREPARED FOR:  
 THE CITY OF ATWATER  
 750 BELLEVUE ROAD  
 ATWATER, CA 95301

PREPARED BY:  
**JLB** Traffic Engineering, Inc.  
 1300 E. SHAW AVE STE. 103  
 FRESNO, CA 93710  
 PHONE: (559) 570-8991  
 EMAIL: info@JLBtraffic.com



*JLB*  
 R.C.E. 62971  
 DATE: 4.23.18

CITY OF ATWATER  
 COMMUNITY DEVELOPMENT DEPARTMENT  
 ENGINEERING DIVISION

OLIVE AVENUE AND WINTON WAY

TRAFFIC SIGNAL

Scale: AS NOTED		Date: 03/02/2018	
Fld. Bk.:	JA	Approved By:	Sheet 8 of 15
Drawn:	JLB	Checked:	File No.
Checked:	JLB		
REVISIONS	Date	By	



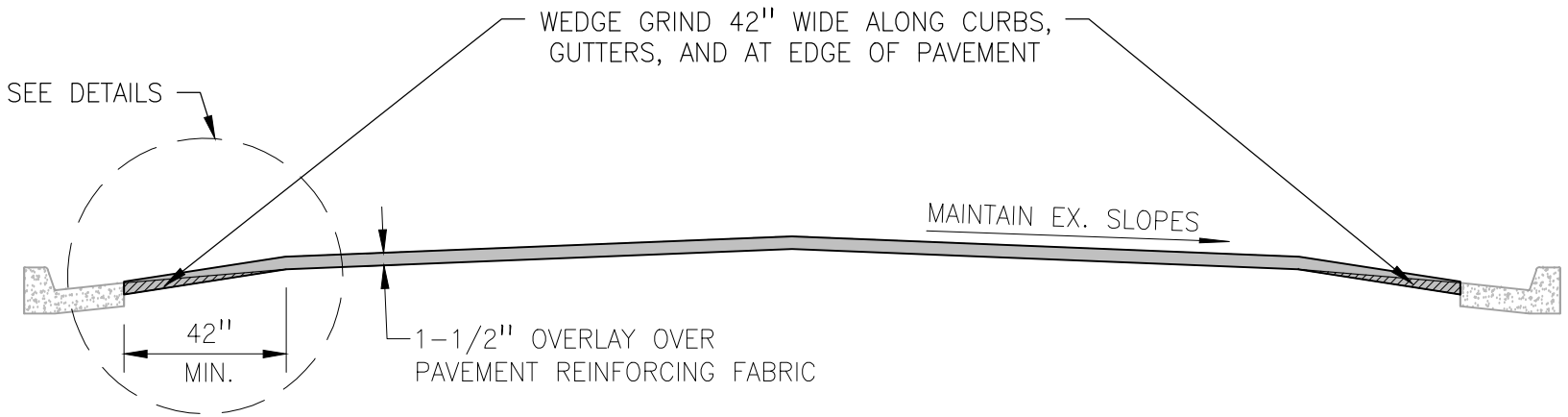

TYPICAL CROSS SECTION

TYPICAL CROSS SECTION

CITY OF ATWATER  
STANDARD DETAIL

REV.	BY

APPROVED	COMMUNITY DEVELOPMENT DEPARTMENT

DRAWN:	J.V.P.	NO. 1
DATE:	09.07.23	
SCALE:	N.T.S.	

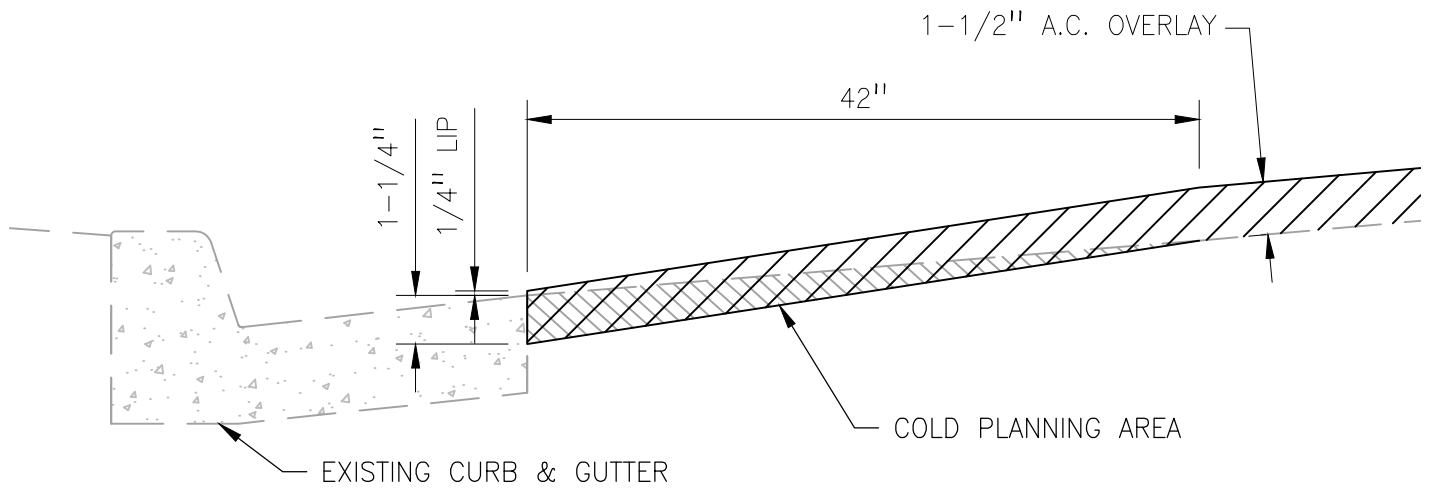

**ADJACENT TO CONCRETE**

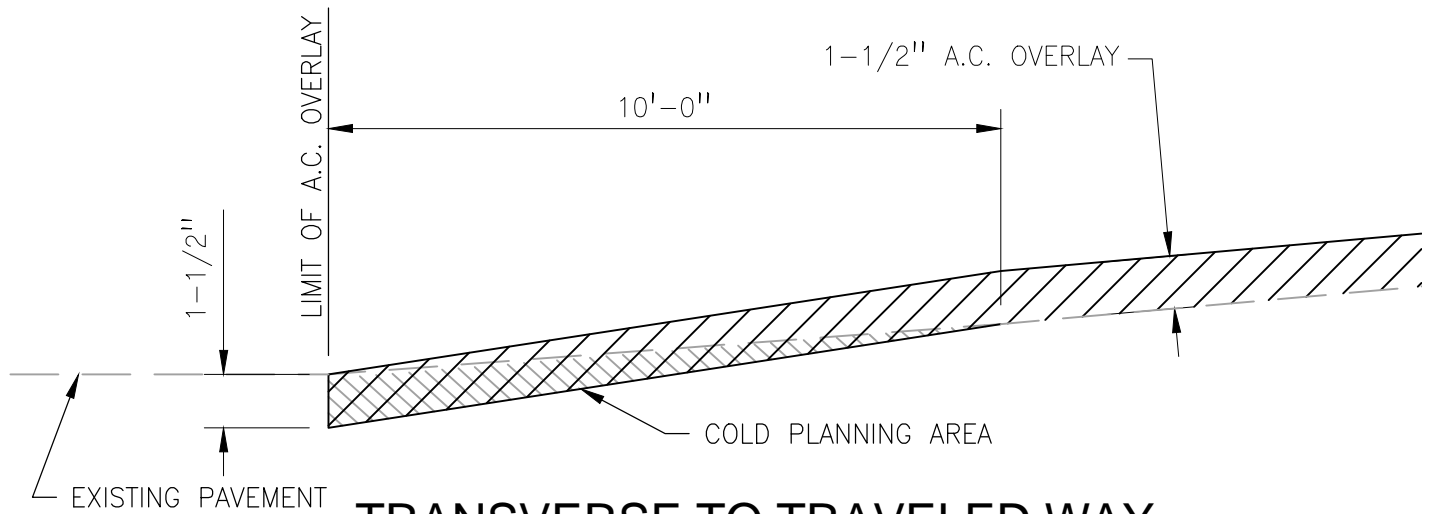

**TRANSVERSE TO TRAVELED WAY**

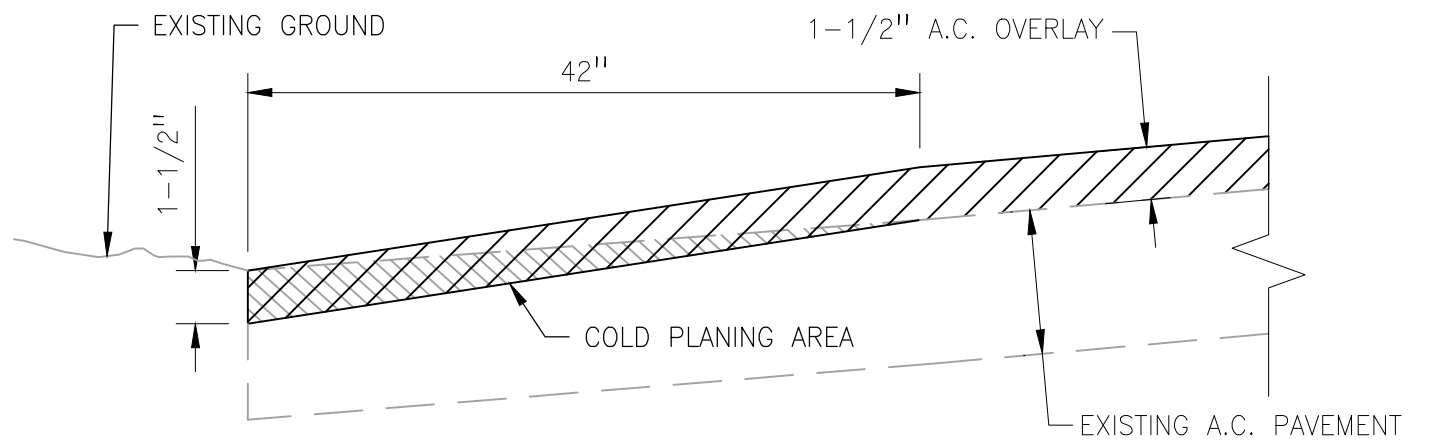

**AT EDGE OF PAVEMENT**

		A.C. OVERLAY OVER PAVEMENT		CITY OF ATWATER STANDARD DETAIL	
		APPROVED _____		DRAWN: J.V.P	NO.
		COMMUNITY DEVELOPMENT DEPARTMENT		DATE: 09.07.23	2
REV.	BY			SCALE: N.T.S	

LOT LINE MONUMENTATION

Survey monuments shall be set at all corners, angle points, and curve points of all lots. Monuments shall be 1-inch O.D. (3/4 inch I.D.) galvanized iron pipe, 24 inches in length, set 12 inches below finish grade, and shall be visibly tagged or stamped with the certificate number of the surveyor or engineer setting it.

SUBDIVISION BOUNDARY MONUMENTATION

Subdivision boundary monuments, except those in street pavement, shall be 1-1/2 inches O.D. (1-1/4 inch I.D.) galvanized iron pipe, 24 inches in length, set 12 inches below finish grade, capped and tagged. Subdivision boundary monuments in street pavement shall be 1-inch O.D. (3/4-inch I.D.) galvanized iron pipe, 18 inches in length, top of pipe shall be set 1/2 inch below the pavement surface.

STREET CENTERLINE MONUMENTATION

Survey monuments shall be set at all street centerline intersections. Number and location of monuments within a subdivision is subject to the approval of the City Engineer. Centerline and street intersection monuments shall be 1-inch O.D. (3/4-inch I.D.) galvanized iron pipe, and not less than 18 inches in length. Top of the pipe shall be 1/2-inch below pavement surface.

SECTION AND QUARTER CORNER MONUMENTS

Permanent survey monuments shall be placed at all section and quarter corners within the improvement. The section corner monuments shall be Class "B" concrete, poured in place, with minimum dimensions of 6" diameter by 24 inches. Plates shall be placed before the concrete has acquired its initial set and shall be firmly embedded in the concrete. Monuments shall be visibly tagged or stamped with the certificate number of the surveyor or engineer setting it. In paved areas, a monument box is required, with lettering "MONUMENT" on cover. Frame to be set in 5 sack concrete mix (Class "B" per State specifications) 24 inches square by 6 inches deep, matching pavement grades. Use Brooks 4-TT or Christy G5 concrete boxes with traffic lids, or an approved equal.

	ENGINEERING DIVISION		CITY OF ATWATER, CALIF.	
	TITLE		STANDARD PLAN	
	SURVEY MONUMENTATION		M-10	
	DRN.	APPROVED BY:	DATE:	
DATE	<i>Win Westfall</i>	5-18-82		
REV. 4/83	WIN WESTFALL, CITY ENGINEER			

RESTORING MONUMENTS

If any monument is found in a perishable condition, it shall be replaced with a permanent monument and be so noted on the final map. The instructions as set forth in the 1973 "Manual of Instructions for the Survey of Public Lands of the United States" published by the Bureau of Land Management, Department of the Interior, Washington, D.C. shall be followed for the subdivision of public lands and privately owned lands, in the restoration of lost or obliterated corners, and the retracement of section lines.

RELATION TO ADJACENT AREA

The surveyor shall clearly show on the final map the character, description and positions of all stakes, monuments, or other evidences found on the ground and used to determine the boundaries of the tract. If necessary, a Record of Survey map shall be separately recorded.

The final map shall show corners of all adjoining subdivisions, or portions thereof, by lot or block number, tract name and/or number, and place of record. The relation of the tract to adjoining subdivisions shall be shown by ties.

Whenever the City Engineer or County Surveyor has established the centerline of a street or alley, the data shall be shown on the final map, indicating all monuments found and making reference to a field book or map. If the points were reset by ties, the fact shall be stated.

The final map shall show all city boundary lines crossing or adjoining the subdivision clearly designated and tied in.

The final map shall show suitable primary survey control points, including section corners, and monuments existing outside of the proposed subdivision, as required.

BOUNDARY LINES

City boundaries, and lines between registered (Torrens Title) and unregistered land, and between a separate ownership of registered land, shall be lot lines; that is, such a line shall not cut a lot, but shall be made a line of a lot, except where permitted by the City Engineer.

	ENGINEERING DIVISION		CITY OF ATWATER, CALIF.	
	TITLE		STANDARD PLAN	
	SURVEY MONUMENTATION		M-11	
	DRN.	APPROVED BY:	DATE:	
DATE	<i>Wm Westfall</i>	5-18-82		
REV.	CITY ENGINEER			

NOTATION OF MONUMENT ON THE FINAL MAP

The character, type and positions of all monuments and encasements shall be noted on the final map. If any shortage or excess of distance is found on the ground between existing monuments, compared with the original record, any division of the total must bear its proportion of such shortage or excess. If a monument is replaced, indicate type and condition of monument found, and the date of replacement.

Sheet 3 of 3

	ENGINEERING DIVISION		CITY OF ATWATER, CALIF.
	TITLE SURVEY MONUMENTATION		STANDARD PLAN
	DRN.	APPROVED BY: <i>Win Woodall</i>	DATE: 5-18-82
	DATE	, CITY ENGINEER	
REV.			M-12

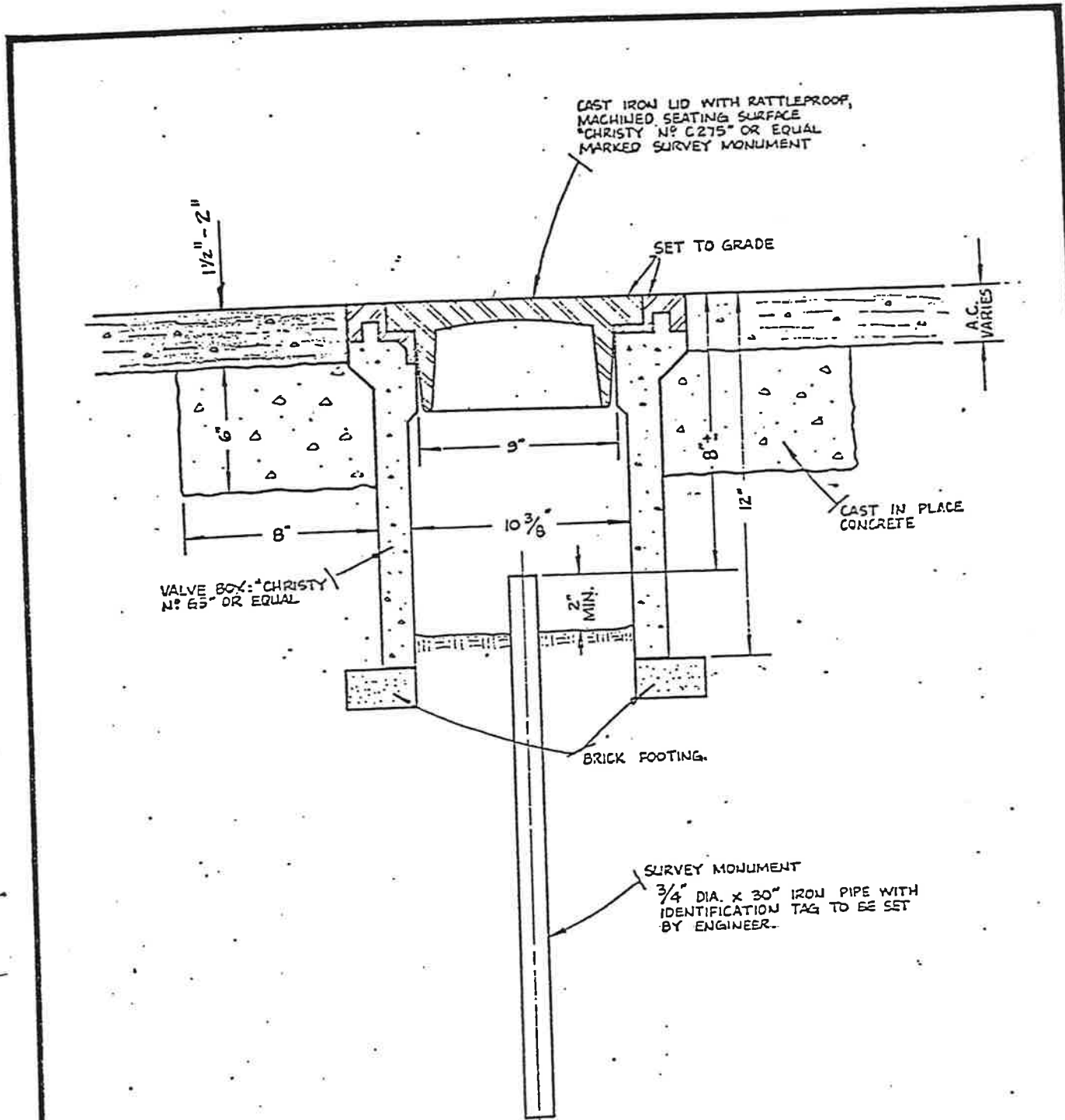

CAST IRON LID WITH RATTLEPROOF, MACHINED SEATING SURFACE "CHRISTY N° C275" OR EQUAL MARKED SURVEY MONUMENT

SET TO GRADE

A.C. VARIES

CAST IN PLACE CONCRETE

VALVE BOX: "CHRISTY N° 65" OR EQUAL

BRICK FOOTING

SURVEY MONUMENT  
 3/4" DIA. X 30" IRON PIPE WITH IDENTIFICATION TAG TO BE SET BY ENGINEER.

NOTE: MONUMENTS ARE TO BE SET AFTER STREETS HAVE BEEN PAVED.

ENGINEERING DIVISION		CITY OF ATWATER, CALIF.	
TITLE		STANDARD PLAN	
MONUMENT BOX		M-13	
DRN.	APPROVED BY:	DATE:	
	<i>John E. Medina</i>	8/24/98	(Modified)
DATE	JOHN E. MEDINA, CITY ENGINEER		
REV. 12/94/0			Page 000 of 340



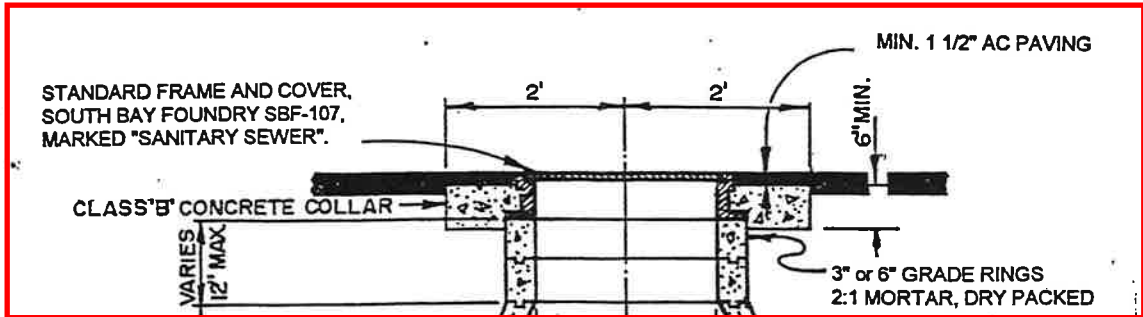

STANDARD FRAME AND COVER,  
SOUTH BAY FOUNDRY SBF-107,  
MARKED "SANITARY SEWER".

MIN. 1 1/2" AC PAVING

CLASS 'B' CONCRETE COLLAR

VARIABLES  
12" MAX

3" or 6" GRADE RINGS  
2:1 MORTAR, DRY PACKED

CONCENTRIC REINFORCED CONCRETE  
CONE. ECCENTRIC R.C. CONE OPTIONAL  
TO BE APPROVED BY THE CITY ENGINEER

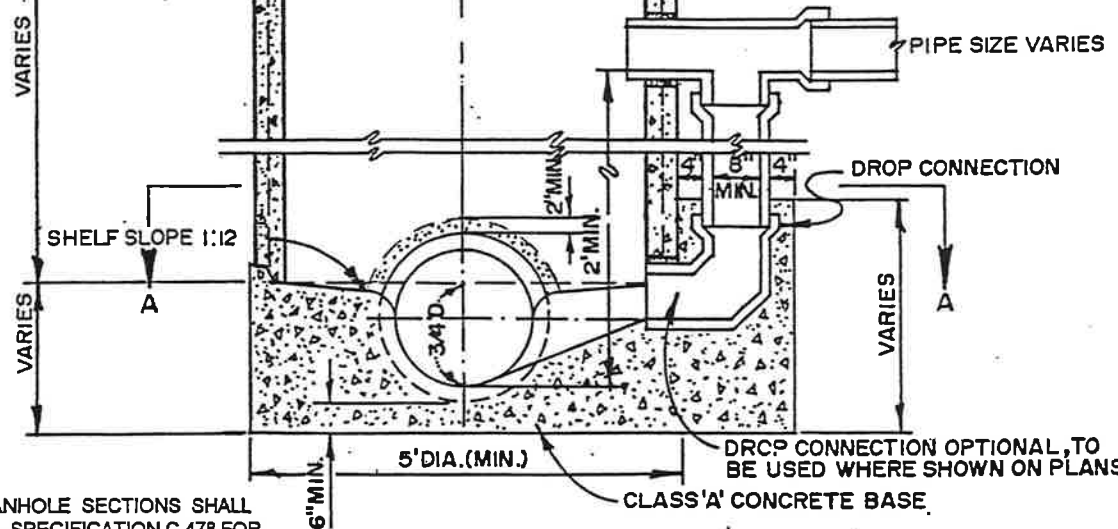

PRE-CAST MANHOLE SECTIONS SHALL  
MEET A.S.T.M. SPECIFICATION C 478 FOR  
CL. III REINFORCED CONCRETE PIPE.  
LENGTHS OF ONE, TWO OR THREE  
FEET ARE OPTIONAL. ALL JOINTS SHALL  
BE GROUTED SMOOTH, INSIDE AND OUT  
AND SHALL BE WATERTIGHT.

PIPE SHALL BE LAID THROUGH THE MANHOLE, THEN  
SMOOTHLY BROKEN OUT AFTER BASE CONCRETE HAS  
SET. CONCRETE SHALL HAVE A SMOOTH, UNIFORM, STEEL  
TROWEL FINISH. AFTER PIPE IS BROKEN OUT, ADDITIONAL  
GROUT SHALL BE APPLIED AND BRUSHED SMOOTH.

WHERE INCOMING AND OUTGOING SEWER PIPES IN MANHOLE  
VARY IN SIZE, EXTEND LOWER HALVES OF SEWER PIPES  
8" BEYOND INSIDE OF WALL AND SHAPE A SMOOTH, EVEN  
TRANSITION CHANNEL BETWEEN PIPES.

MATCH SOFFITS OF PIPE AT MANHOLES, JOINING DIFFERENT  
SIZED PIPES, IF LARGER IS DOWNSTREAM.

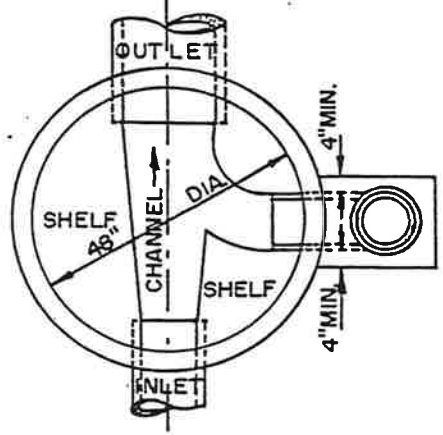

SECTION A-A

	ENGINEERING DIVISION		CITY OF ATWATER, CALIF		
	TITLE <b>SANITARY SEWER MANHOLE DETAILS</b>				STANDARD PLAN
	DRN. H.E.D.	APPROVED BY:	DATE:	S-1	
	DATE 9/81	<i>[Signature]</i>	2-22-96		
REV. 2/96	CITY ENGINEER				

NOTE:  
 (1) CASTING - FRAME AND COVER - PINKERTON  
 FOUNDRY No. A-490 - PHOENIX IRON WORKS  
 No. PF 1012-L - OR APPROVED EQUAL.

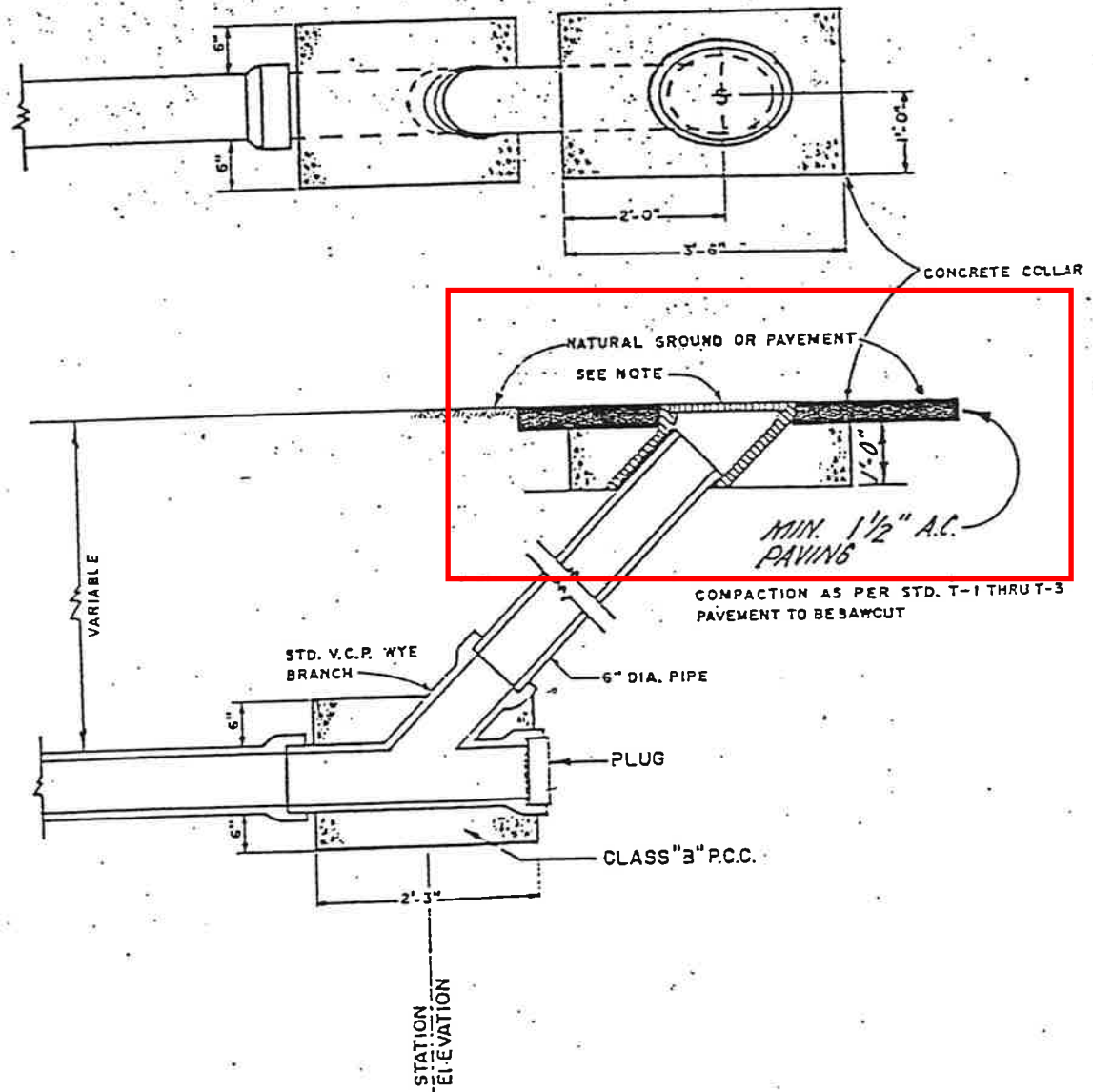

ENGINEERING DIVISION		CITY OF ATWATER, CALIF.	
TITLE		STANDARD PLAN	
CLEANOUT		S-4	
DRN.	APPROVED BY:	DATE:	(MODIFIED)
DATE	<i>[Signature]</i>	8/24/98	
REV.	JOHN E. MEDINA, CITY ENGINEER		

DIA.	A	B	C	D	E	F	MIN. G
54"	75"	54"	11½"	5½"	75"	10½"	5½"
60"	82"	60"	12"	6"	82"	11"	6"
66"	89"	66"	12½"	6½"	89"	11½"	6½"
72"	96"	72"	13"	7"	96"	12"	7"
84"	110"	84"	14"	8"	110"	13"	8"
96"	124"	96"	15"	9"	124"	14"	9"
120"	154"	120"	18"	12"	154"	17"	12"

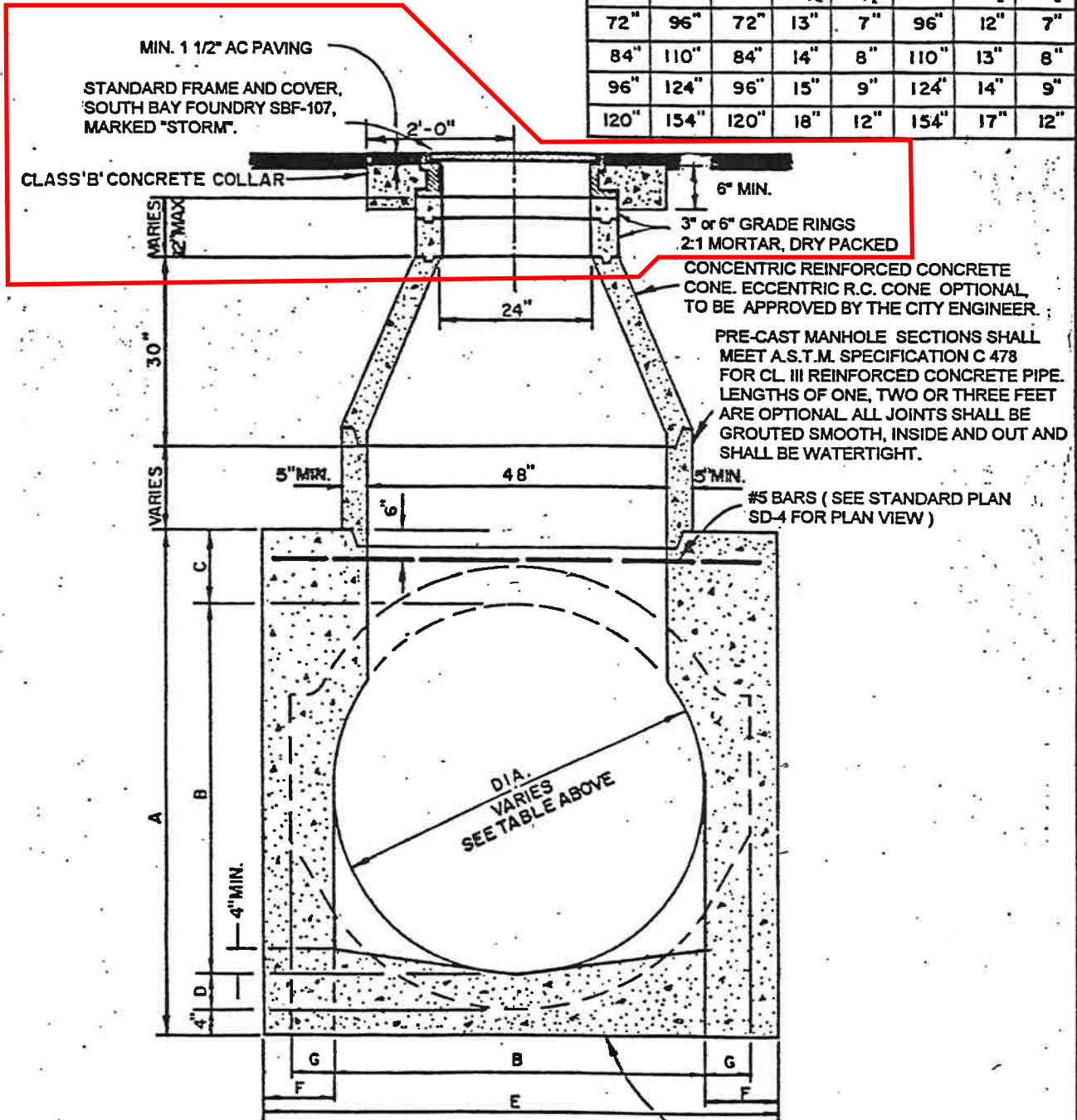

**TYPICAL CONCENTRIC  
MANHOLE  
54" THRU 120"**

POURED-IN-PLACE P.C.C. BASE  
CLASS 'A' P.C.C. CONFORMING TO SECTION 90, STANDARD SPECIFICATIONS, STATE OF CALIFORNIA, 1992 EDITION OR AN APPROVED EQUAL, SHALL BE USED FOR M.H. BASES AND C.I.P.P.

	ENGINEERING DIVISION		CITY OF ATWATER, CALIF.	
	TITLE: STORM DRAIN M.H. FOR 54"-120" C.I.P.P.			
	DRN. H.E.D.	APPROVED BY:	DATE:	STANDARD PLAN
	DATE 8/81	<i>John A. Haring</i>	2-22-96	SD-3
REV. 2/96	CITY ENGINEER		Page 309 of 346	

WATEROUS WB-67  
 AMERICAN DARLING B-84-B  
 DR MULLER A-423  
 FIRE HYDRANTS SHEAR PAD &  
 VALVE BOX CALLER SHALL BE  
 CLASS "B" P.C.C W/ 1/2" RADIUS  
 TOOLED EDGE ALL AROUND

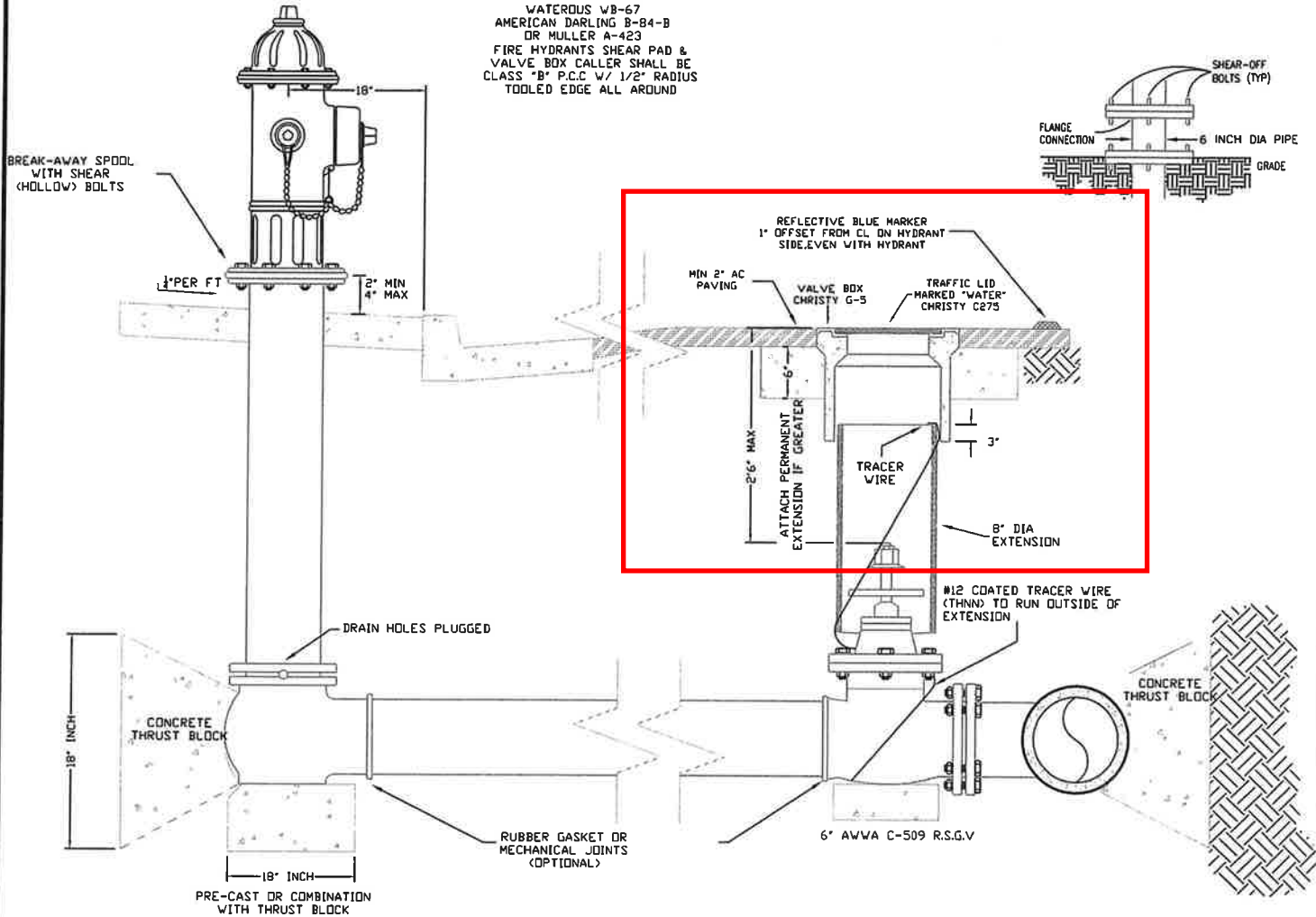

STREET

STREET



### TYPICAL LOCATIONS

FIRE HYDRANTS SHALL BE PLACED AS DIRECTED BY THE CITY ENGINEER. A MIN OF 5' DISTANCE FROM DRIVEWAYS, 10' FROM SEWER, VAULTS, PULL BOXES, U/G TRANSFORMERS MANHOLES. 20' FROM POWER POLES, STREET LIGHTS & TREES.

## FIRE HYDRANT INSTALLATION DETAILS

CITY OF ATWATER  
 STANDARD DETAIL

REV.		BY	

APPROVED   
 COMMUNITY DEVELOPMENT DEPARTMENT

DRAWN:		NO.
DATE:	11/10/10	WA-08
SCALE:		

**CENTERLINES**

(2 LANE HIGHWAYS)

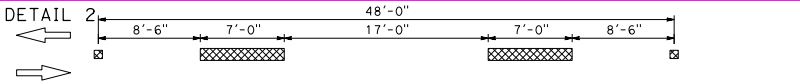
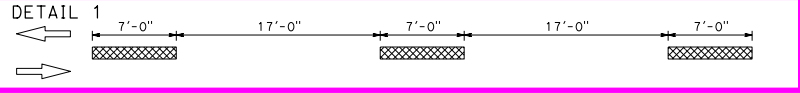

~~DETAIL 3~~ DETAIL 3 DELETED

~~DETAIL 4~~ DETAIL 4 DELETED

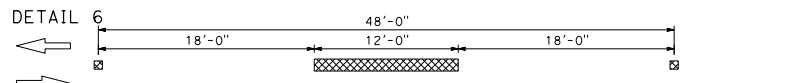
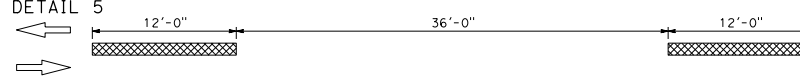

~~DETAIL 7~~ DETAIL 7 DELETED

**LANE LINES**

(MULTILANE HIGHWAYS)

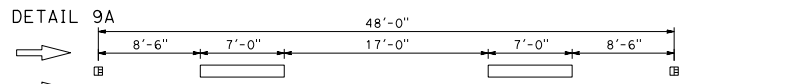
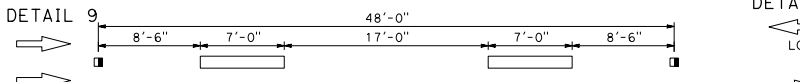
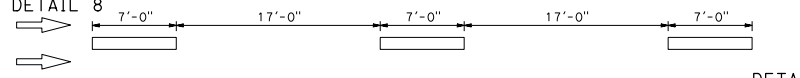

~~DETAIL 10~~ DETAIL 10 DELETED

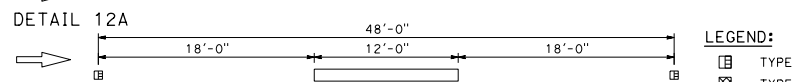
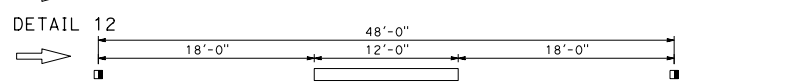
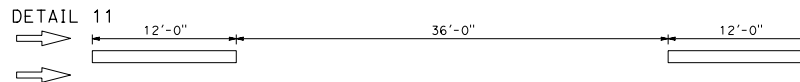

~~DETAIL 13~~ DETAIL 13 DELETED

~~DETAIL 14~~ DETAIL 14 DELETED

~~DETAIL 14A~~ DETAIL 14A DELETED

- LEGEND:**
- TYPE C RED-CLEAR RETROREFLECTIVE MARKER
  - TYPE D TWO-WAY YELLOW RETROREFLECTIVE MARKER
  - TYPE G ONE-WAY CLEAR RETROREFLECTIVE MARKER
  - TYPE H ONE-WAY YELLOW RETROREFLECTIVE MARKER
  - 6" WHITE LINE
  - 6" YELLOW LINE

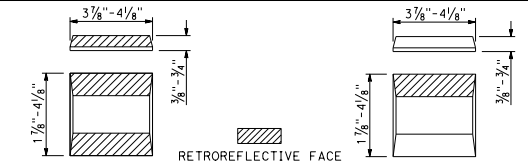

TYPE C AND TYPE D TYPE G AND TYPE H

**MARKER DETAILS**

**NO PASSING ZONES - ONE DIRECTION**

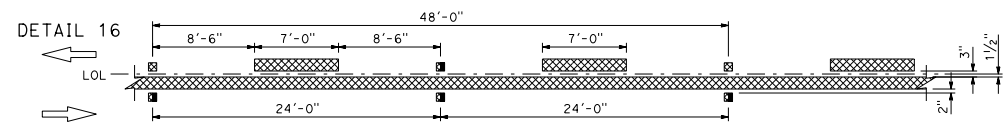
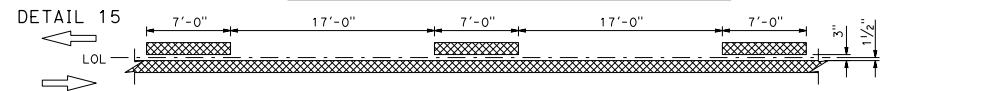

~~DETAIL 17~~ DETAIL 17 DELETED

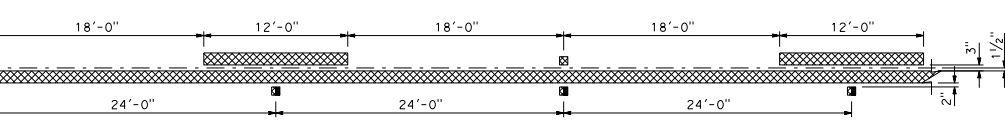
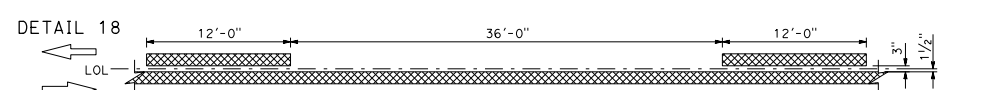

~~DETAIL 20~~ DETAIL 20 DELETED

**NO PASSING ZONES - TWO DIRECTION**

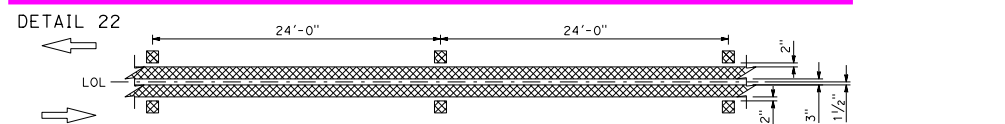
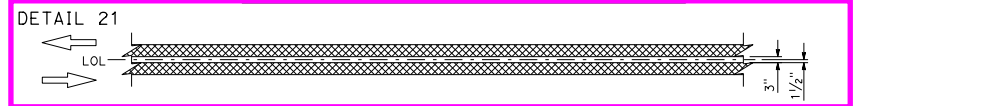

~~DETAIL 23~~ DETAIL 23 DELETED

**PAVEMENT MARKERS AND TRAFFIC LINES TYPICAL DETAILS**

STATE OF CALIFORNIA  
DEPARTMENT OF TRANSPORTATION

NO SCALE

DIST	COUNTY	ROUTE	POST MILES TOTAL PROJECT	SHEET NO.	TOTAL SHEETS

Registered Civil Engineer  
 September 20, 2024  
 PLANS APPROVAL DATE  
 THE STATE OF CALIFORNIA OR ITS OFFICERS OR AGENTS SHALL NOT BE RESPONSIBLE FOR THE ACCURACY OR COMPLETENESS OF SCANNED COPIES OF THIS PLAN SHEET.

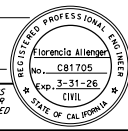

2024 STANDARD PLAN A20A

12

**A20A**

T-1-24

### LEFT EDGE LINES

(DIVIDED HIGHWAYS)  
See Note

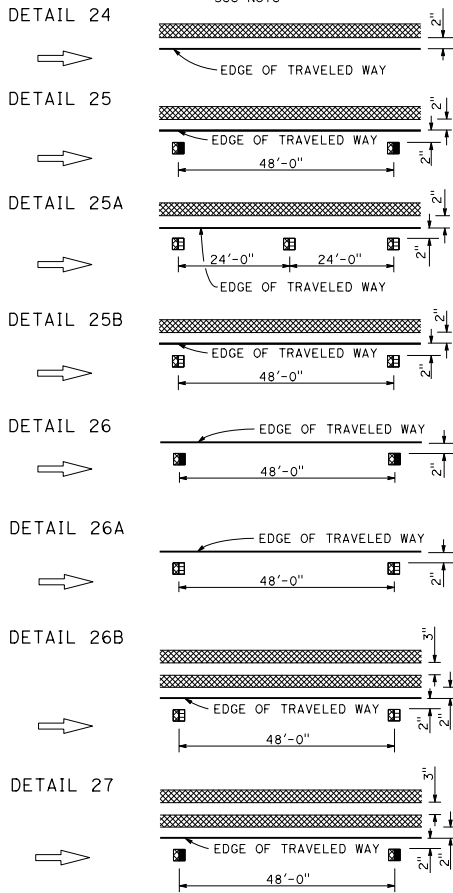

### RIGHT EDGE LINES

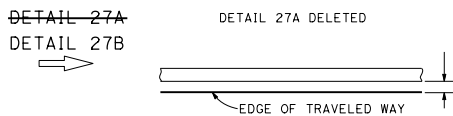

### RIGHT EDGE LINE EXTENSION THROUGH INTERSECTIONS

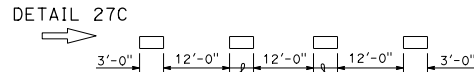

### MEDIAN ISLANDS

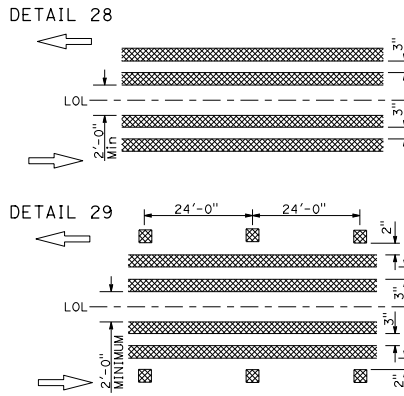

DETAIL 30 DELETED

### TWO-WAY LEFT TURN LANES

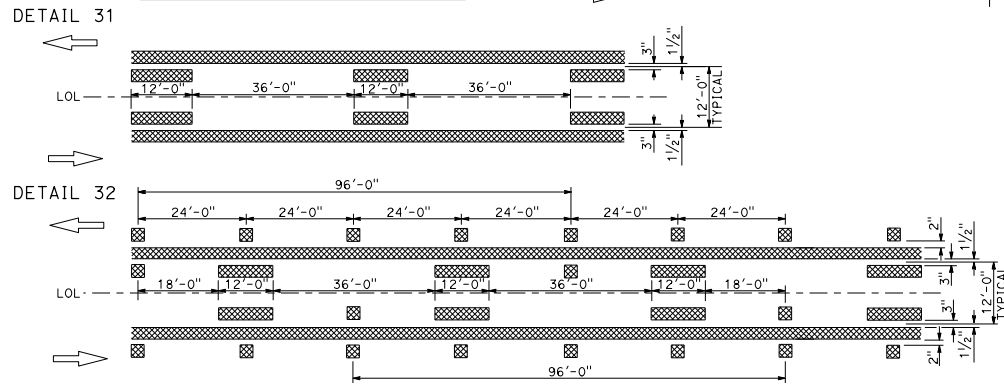

DETAIL 33 DELETED

### LEGEND:

- TYPE D TWO-WAY YELLOW RETROREFLECTIVE MARKER
- TYPE H ONE-WAY YELLOW RETROREFLECTIVE MARKER
- TYPE RY RED-YELLOW RETROREFLECTIVE MARKER
- 6" WHITE LINE
- 6" YELLOW LINE

### INTERSECTION TREATMENTS

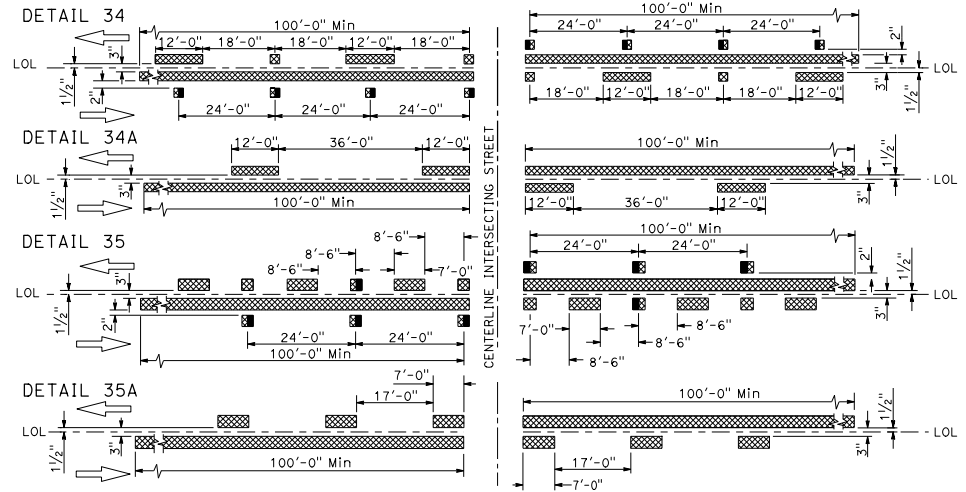

### MARKER DETAILS

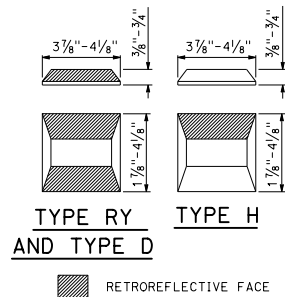

STATE OF CALIFORNIA  
DEPARTMENT OF TRANSPORTATION

## PAVEMENT MARKERS AND TRAFFIC LINES TYPICAL DETAILS

NO SCALE

LEFT EDGE LINES NOTE:  
On freeways use traffic stripe details with Type RY markers.

D16+	COUNTY	ROUTE	POST MILES TOTAL PROJECT	SHEET TOTAL SHEETS

September 20, 2024  
PLANS APPROVAL DATE

REGISTERED CIVIL ENGINEER  
Floresca Alleno  
No. C81705  
Exp. 3-31-26  
CIVIL  
STATE OF CALIFORNIA

**EXIT RAMP NEUTRAL AREA (GORE) TREATMENT**

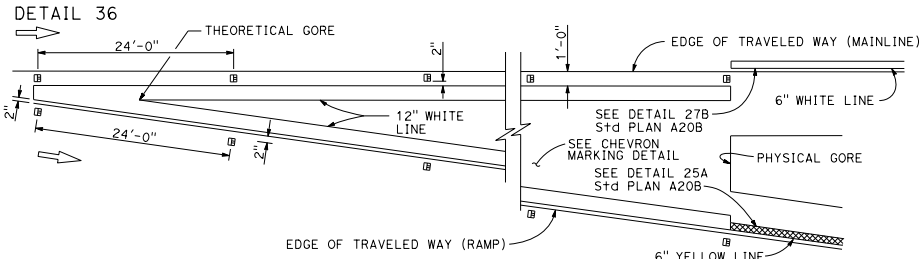

**ENTRANCE RAMP NEUTRAL AREA (MERGE) TREATMENT**

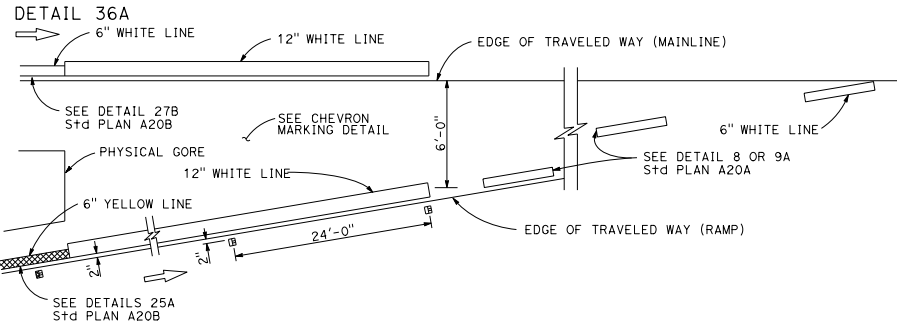

**ENTRANCE RAMP NEUTRAL AREA (ACCELERATION LANE) TREATMENT**

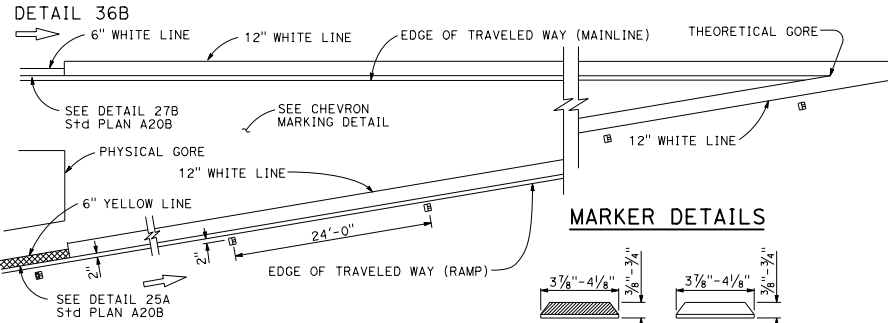

**MARKER DETAILS**

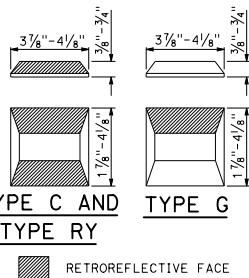

**LEGEND:**

- ▣ TYPE C RED-CLEAR RETROREFLECTIVE MARKER
- ▣ TYPE G ONE-WAY CLEAR RETROREFLECTIVE MARKER
- ▣ TYPE RY RED-YELLOW RETROREFLECTIVE MARKER

**NOTES:**

Install a minimum of 1 chevron in the gore area, if at least 1 chevron will not fit into the gore area, do not install chevrons. Terminate chevron markings at physical gore.

Gore area chevron pavement markings shown. For Exit and Entrance Ramp channelizing lines details, see Details 36, 36A, and 36B.

DIST	COUNTY	ROUTE	POST MILES TOTAL PROJECT	SHEET NO.	TOTAL SHEETS

REGISTERED CIVIL ENGINEER

September 20, 2024

PLANS APPROVAL DATE

THE STATE OF CALIFORNIA OR ITS OFFICERS OR AGENTS SHALL NOT BE RESPONSIBLE FOR THE ACCURACY OR COMPLETENESS OF SCANNED COPIES OF THIS PLAN SHEET.

**LANE DROP AT EXIT RAMP**

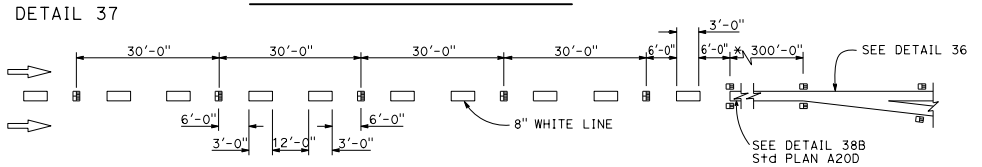

\* The solid channelizing line shown may be omitted on short auxiliary lanes where weaving length is critical.

DETAIL 37A DETAIL 37A DELETED

**LANE DROP AT INTERSECTIONS**

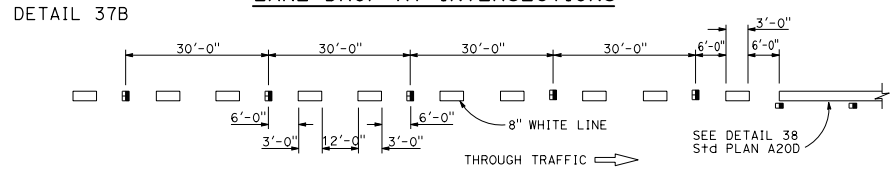

DETAIL 37C DETAIL 37C DELETED

**CHEVRON PAVEMENT MARKINGS AT EXIT RAMP GORE AREA**

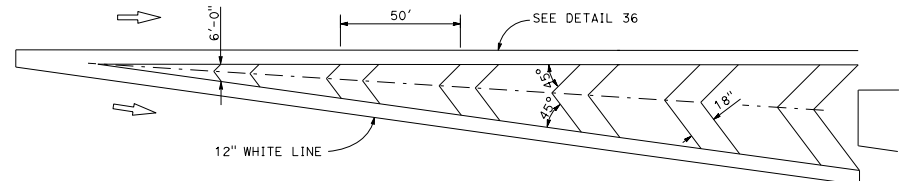

**CHEVRON PAVEMENT MARKINGS AT ENTRANCE RAMP GORE AREA**

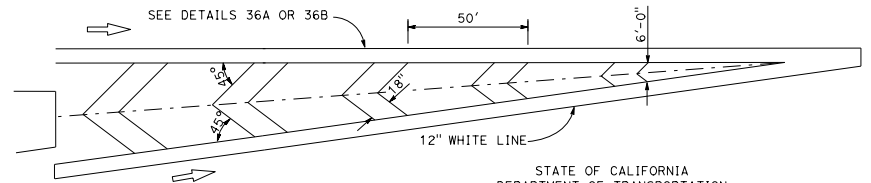

**PAVEMENT MARKERS AND TRAFFIC LINES TYPICAL DETAILS**

NO SCALE

**A20C**

2024 STANDARD PLAN A20C

14

[Return to Table of Contents](#)

### CHANNELIZING LINE

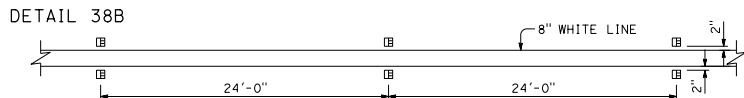
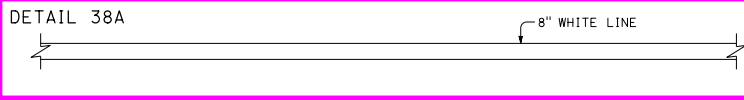
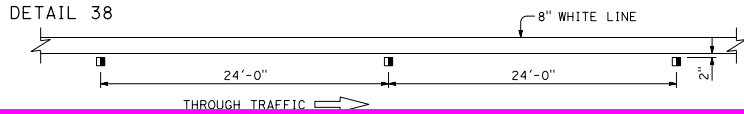

DETAIL 38C  
DETAIL 38C DELETED

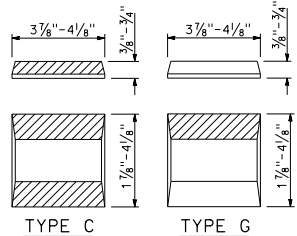
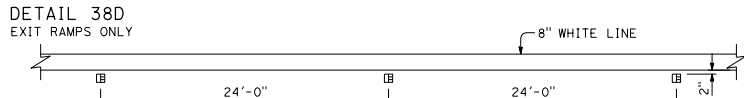

### MARKER DETAILS

RETROREFLECTIVE FACE

### BIKE LANE LINE



### INTERSECTION LINE BIKE LANE

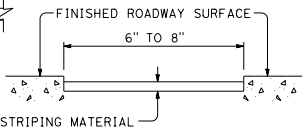
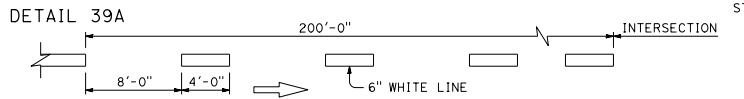

### DETAIL FOR RECESSED TRAFFIC STRIPE

See Notes A and B

- RECESSED NOTES:**
- A. See typical traffic line details for pavement marking patterns.
  - B. See Standard Specifications for recess depth and recess striping material thickness.

### LANE LINE EXTENSIONS THROUGH INTERSECTIONS



DETAIL 40A  
DETAIL 40A DELETED

### CENTERLINE EXTENSIONS THROUGH INTERSECTIONS



DETAIL 41A  
DETAIL 41A DELETED

- LEGEND:**
- TYPE C RED-CLEAR RETROREFLECTIVE MARKER
  - TYPE G ONE-WAY CLEAR RETROREFLECTIVE MARKER
  - 6" YELLOW LINE

DIST	COUNTY	ROUTE	POST MILES TOTAL PROJECT	SHEET NO.	TOTAL SHEETS
------	--------	-------	--------------------------	-----------	--------------

REGISTERED CIVIL ENGINEER  
September 20, 2024  
PLANS APPROVAL DATE  
Floresca Allender  
No. C81705  
Exp. 3-31-26  
CIVIL  
REGISTERED PROFESSIONAL ENGINEER  
STATE OF CALIFORNIA

THE STATE OF CALIFORNIA OR ITS OFFICERS OR AGENTS SHALL NOT BE RESPONSIBLE FOR THE ACCURACY OR COMPLETENESS OF SCANNED COPIES OF THIS PLAN SHEET.

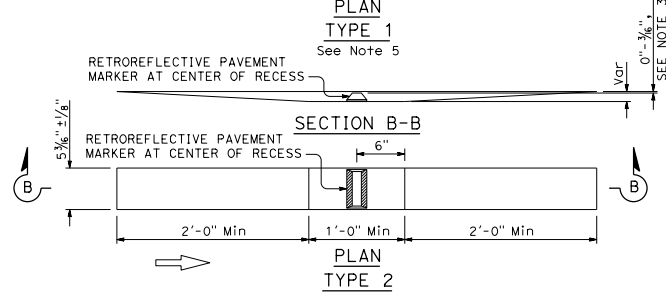
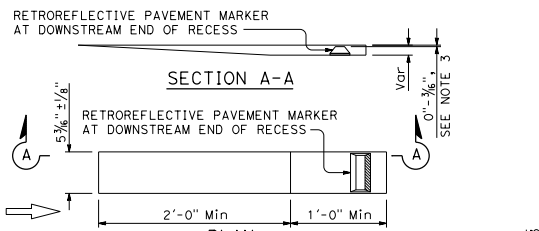

### RECESS DETAIL FOR RETROREFLECTIVE PAVEMENT MARKER

See Note 4

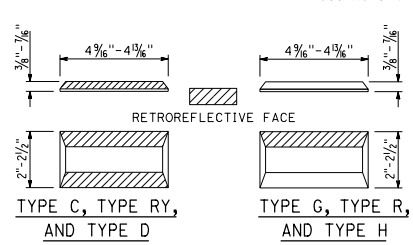

### RETROREFLECTIVE PAVEMENT MARKER FOR RECESSED INSTALLATION

See Notes 1 and 2

## PAVEMENT MARKERS AND TRAFFIC LINES TYPICAL DETAILS

NO SCALE

A20D

2024 STANDARD PLAN A20D

DIST	COUNTY	ROUTE	POST MILES TOTAL PROJECT	SHEET NO.	TOTAL SHEETS

Registered Civil Engineer  
 September 20, 2024  
 PLANS APPROVAL DATE  
 THE STATE OF CALIFORNIA OR ITS OFFICERS OR AGENTS SHALL NOT BE RESPONSIBLE FOR THE ACCURACY OR COMPLETENESS OF SCANNED COPIES OF THIS PLAN SHEET.

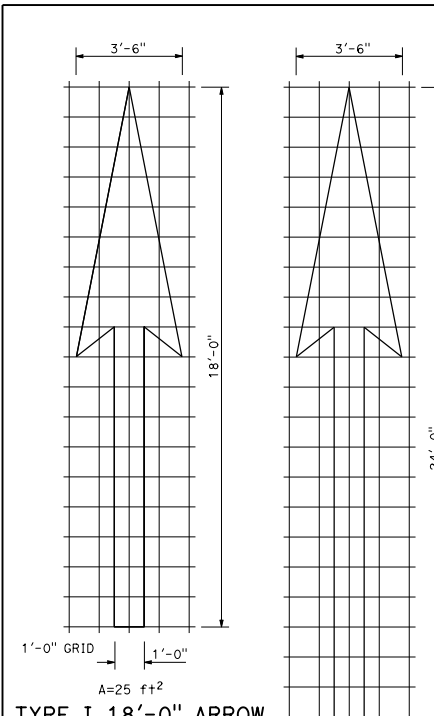

**TYPE I 18'-0" ARROW**  
A=25 ft<sup>2</sup>

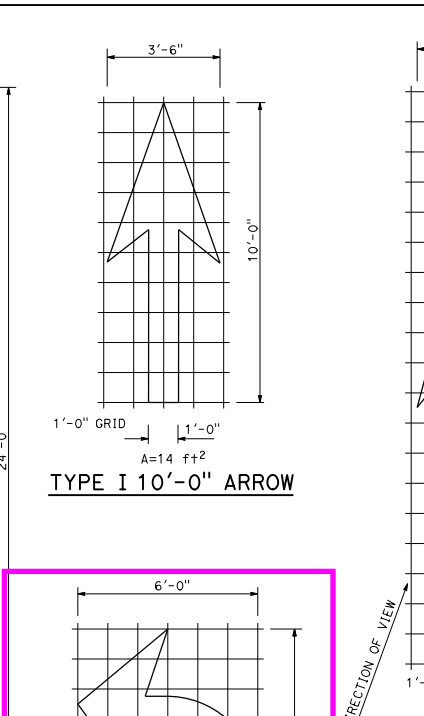

**TYPE I 24'-0" ARROW**  
A=31 ft<sup>2</sup>

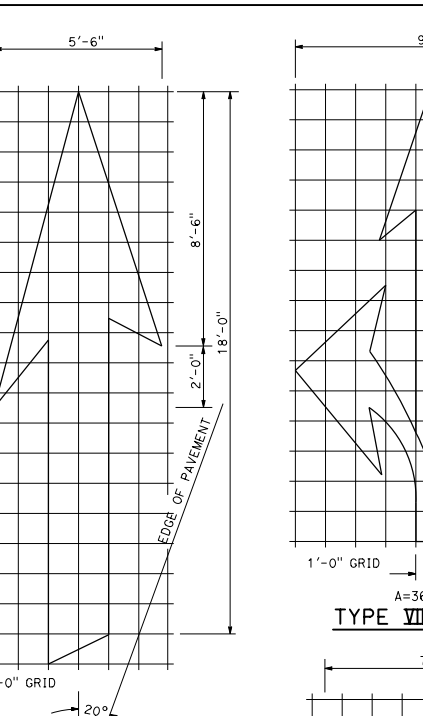

**TYPE I 10'-0" ARROW**  
A=14 ft<sup>2</sup>

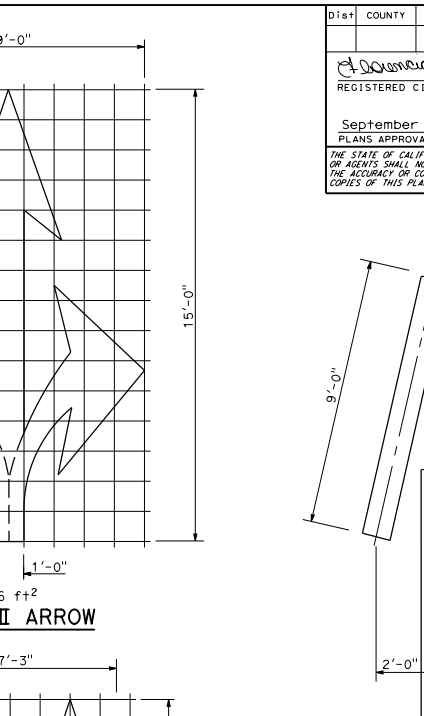

**TYPE III ARROW**  
A=36 ft<sup>2</sup>

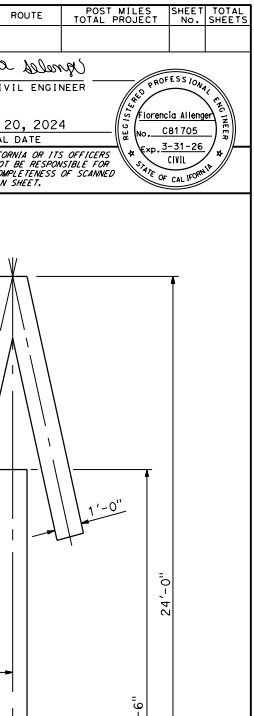

**TYPE V ARROW**  
A=33 ft<sup>2</sup>

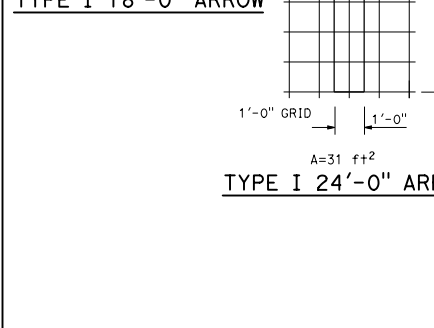

**TYPE IV (L) ARROW**  
A=15 ft<sup>2</sup>  
For Type IV (R) arrow, use mirror image.

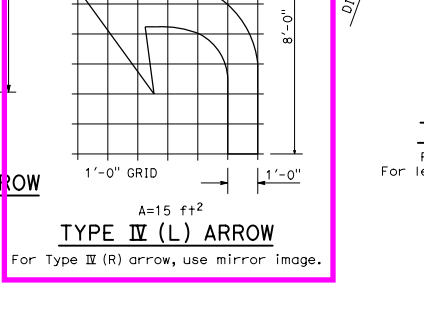

**TYPE VI ARROW**  
A=42 ft<sup>2</sup>  
Right lane drop arrow.  
For left lane, use mirror image.

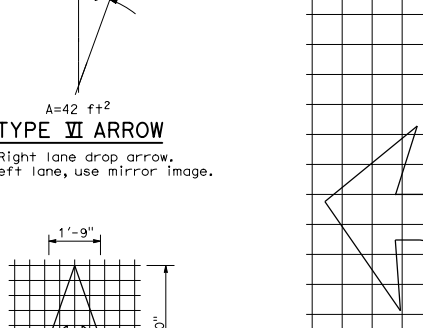

**TYPE VII (L) ARROW**  
A=27 ft<sup>2</sup>  
For Type VII (R) arrow, use mirror image.

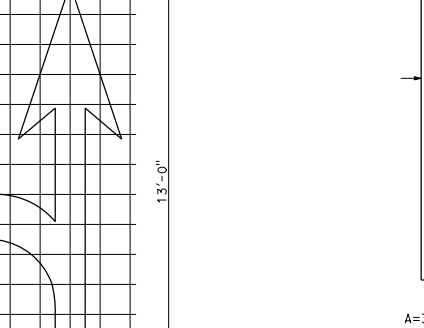

**TYPE VIII ARROW**  
A=36 ft<sup>2</sup>

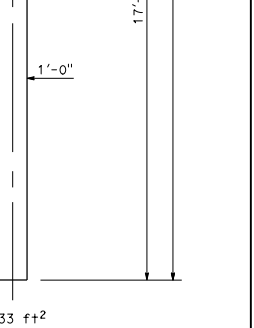

**TYPE IX ARROW**  
A=33 ft<sup>2</sup>

**BIKE LANE ARROW**  
A=3.5 ft<sup>2</sup>

**NOTE:**  
Minor variations in dimensions may be accepted by the Engineer.

**STATE OF CALIFORNIA  
DEPARTMENT OF TRANSPORTATION  
PAVEMENT MARKINGS  
ARROWS  
NO SCALE**

**A24A**

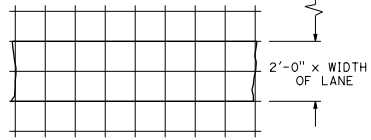
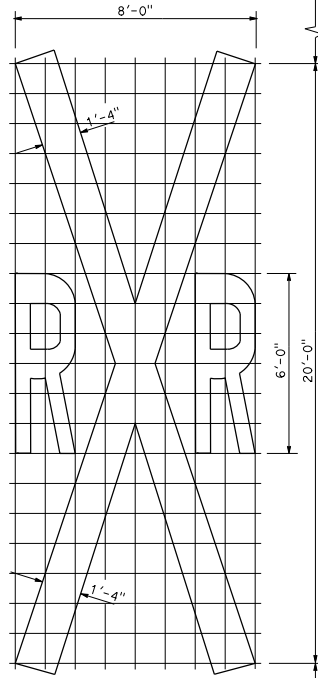
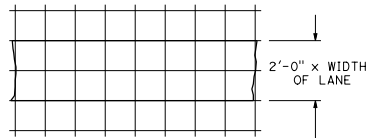

**RAILROAD CROSSING SYMBOL**

× 70 ft<sup>2</sup> does not include the 2'-0" x variable width transverse lines.

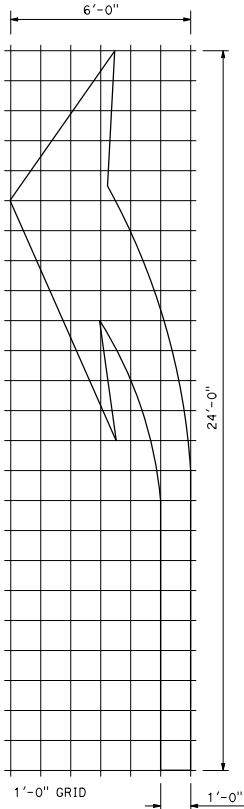

A=42 ft<sup>2</sup>  
**TYPE III (L) ARROW**  
For Type III (R) use mirror image.

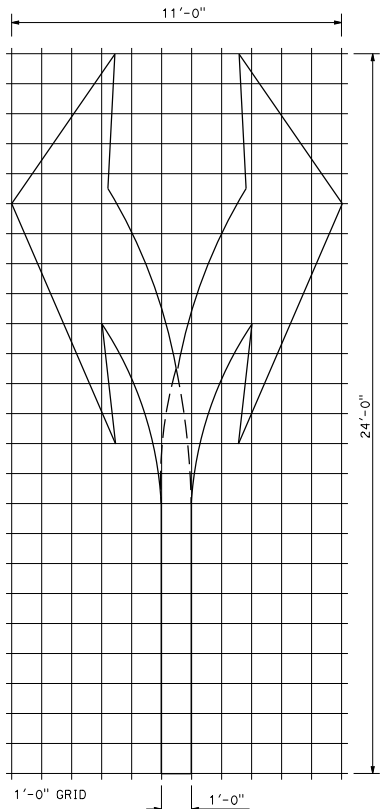

A=73 ft<sup>2</sup>  
**TYPE III (B) ARROW**

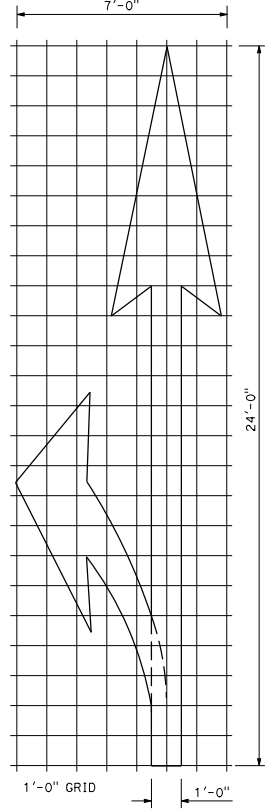

A=45 ft<sup>2</sup>  
**TYPE II (L) ARROW**  
For Type II (R) use mirror image.

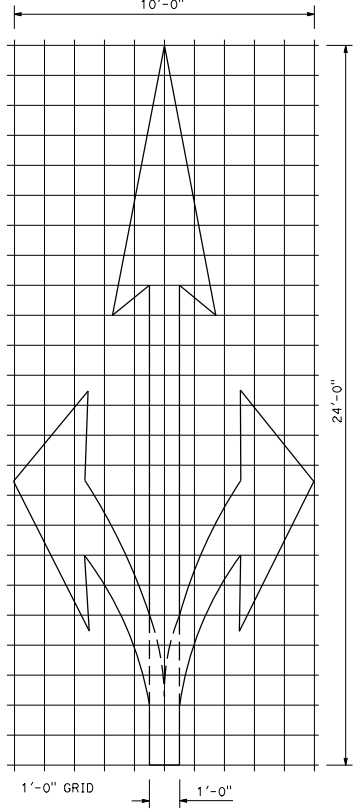

A=59 ft<sup>2</sup>  
**TYPE II (B) ARROW**

**NOTE:**  
Minor variations in dimensions may be accepted by the Engineer.

STATE OF CALIFORNIA  
DEPARTMENT OF TRANSPORTATION  
**PAVEMENT MARKINGS  
ARROWS AND SYMBOLS**  
NO SCALE

DIST	COUNTY	ROUTE	POST MILES TOTAL PROJECT	SHEET NO.	TOTAL SHEETS

*Florencia Allenger*  
REGISTERED CIVIL ENGINEER

September 20, 2024  
PLANS APPROVAL DATE

Florencia Allenger  
No. C81705  
Exp. 3-31-26  
CIVIL  
STATE OF CALIFORNIA

REGISTERED PROFESSIONAL ENGINEER

THE STATE OF CALIFORNIA OR ITS OFFICERS OR AGENTS SHALL NOT BE RESPONSIBLE FOR THE ACCURACY OR COMPLETENESS OF SCANNED COPIES OF THIS PLAN SHEET.

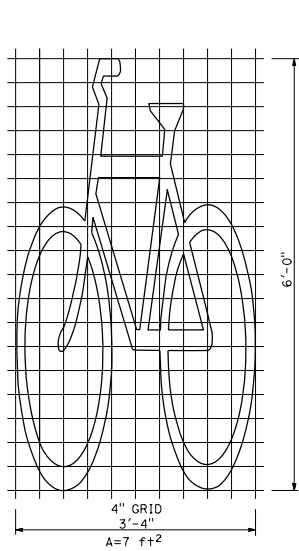

**BIKE LANE SYMBOL  
WITHOUT PERSON**

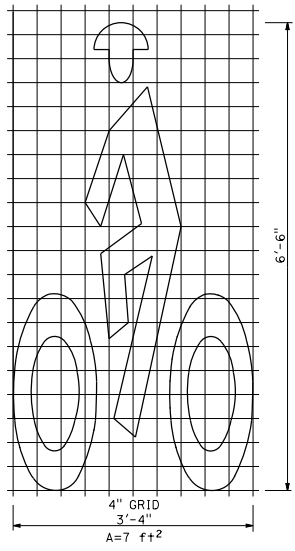

**BIKE LANE SYMBOL  
WITH PERSON**

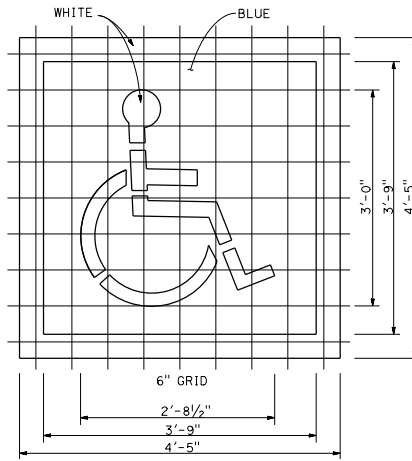

**INTERNATIONAL SYMBOL OF  
ACCESSIBILITY (ISA) MARKING**

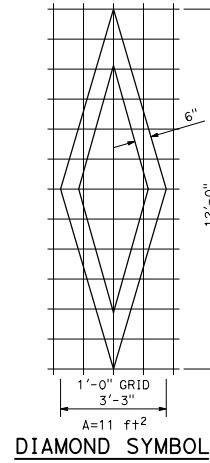

**DIAMOND SYMBOL**

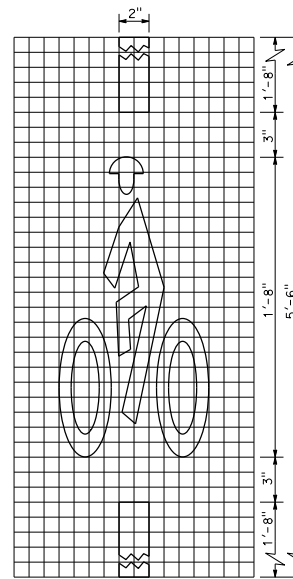

**BIKE LOOP  
DETECTOR SYMBOL**

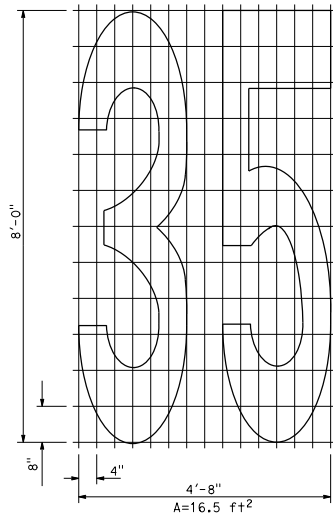
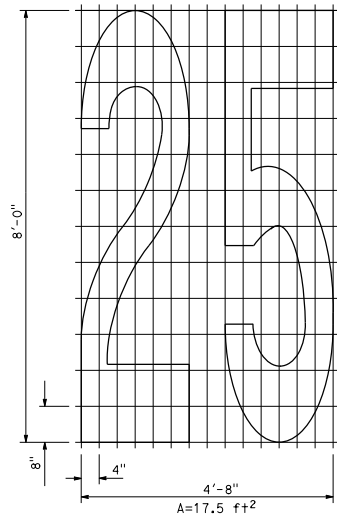

**NUMERALS**

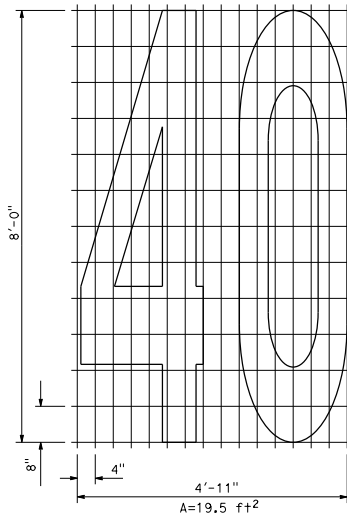

DIST	COUNTY	ROUTE	POST MILES TOTAL PROJECT	SHEET NO.	TOTAL SHEETS

*Florencia Allenger*  
 REGISTERED CIVIL ENGINEER  
 No. C81705  
 Exp. 3-31-26  
 CIVIL  
 STATE OF CALIFORNIA

September 20, 2024  
 PLANS APPROVAL DATE  
 THE STATE OF CALIFORNIA OR ITS OFFICERS  
 OR AGENTS SHALL NOT BE RESPONSIBLE FOR  
 THE ACCURACY OR COMPLETENESS OF SCANNED  
 COPIES OF THIS PLAN SHEET.

**NOTE:**

Minor variations in dimensions may be accepted by the Engineer.

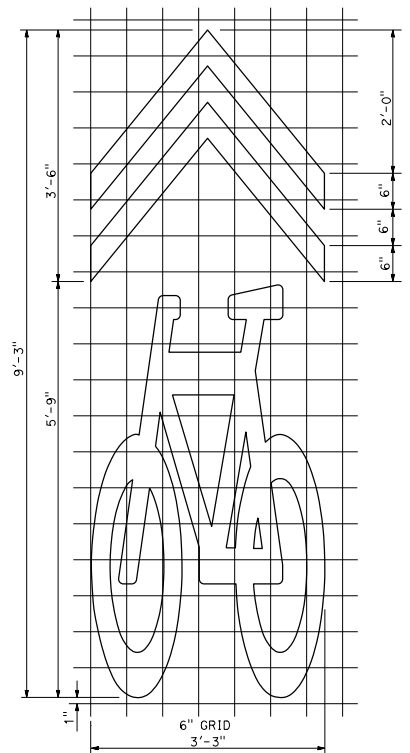

**SHARED ROADWAY BICYCLE MARKING**

STATE OF CALIFORNIA  
 DEPARTMENT OF TRANSPORTATION  
**PAVEMENT MARKINGS  
 SYMBOLS AND NUMERALS**  
 NO SCALE

**A 24C**

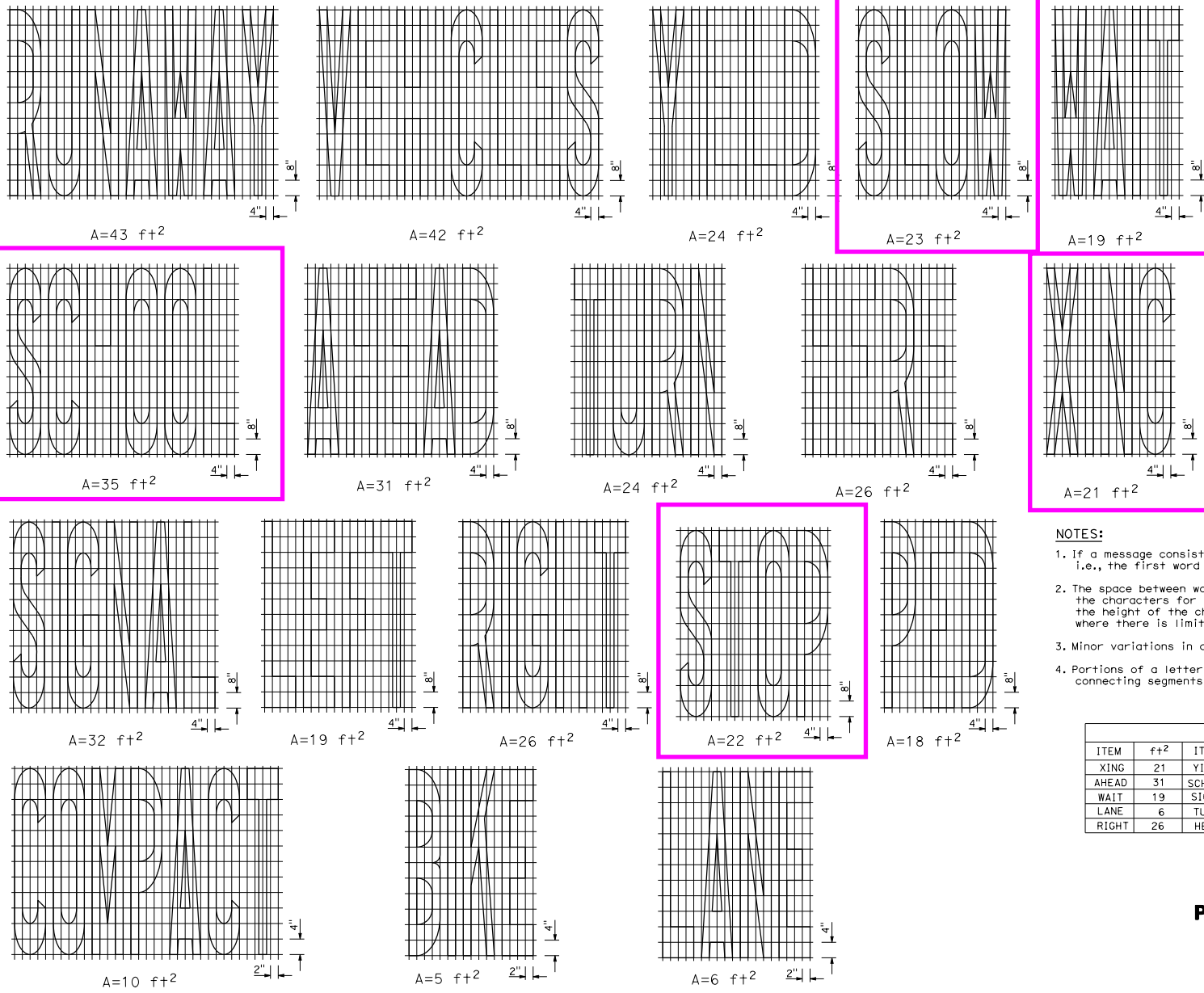

DIST	COUNTY	ROUTE	POST MILES TOTAL PROJECT	SHEET TOTAL NO. SHEETS

*Floresca Allender*  
REGISTERED CIVIL ENGINEER

September 20, 2024  
PLANS APPROVAL DATE

Floresca Allender  
No. C81705  
Exp. 3-31-26  
CIVIL  
STATE OF CALIFORNIA

THE STATE OF CALIFORNIA OR ITS OFFICERS OR AGENTS SHALL NOT BE RESPONSIBLE FOR THE ACCURACY OR COMPLETENESS OF SCANNED COPIES OF THIS PLAN SHEET.

**NOTES:**

1. If a message consists of more than one word, it must read "UP", i.e., the first word must be nearest the driver.
2. The space between words must be at least four times the height of the characters for low speed roads, but not more than ten times the height of the characters. The space may be reduced appropriately where there is limited space because of local conditions.
3. Minor variations in dimensions may be accepted by the Engineer.
4. Portions of a letter, number or symbol may be separated by connecting segments not to exceed 2" in width.

WORD MARKINGS							
ITEM	ft+2	ITEM	ft+2	ITEM	ft+2	ITEM	ft+2
XING	21	YIELD	24	BIKE	5	PED	18
AHEAD	31	SCHOOL	35	SLOW	23	COMPACT	10
WAIT	19	SIGNAL	32	STOP	22	RUNAWAY	43
LANE	6	TURN	24	LEFT	19	VEHICLES	42
RIGHT	26	HERE	26				

STATE OF CALIFORNIA  
DEPARTMENT OF TRANSPORTATION  
**PAVEMENT MARKINGS  
WORDS**  
NO SCALE

**A 24D**

2024 STANDARD PLAN A24D

[Return to Table of Contents](#)

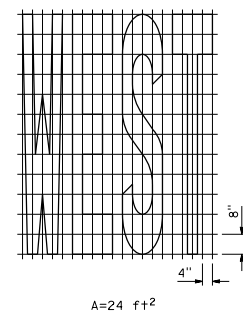
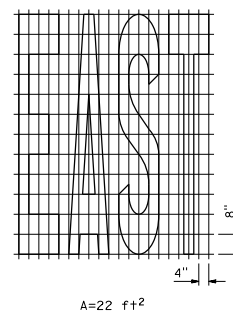
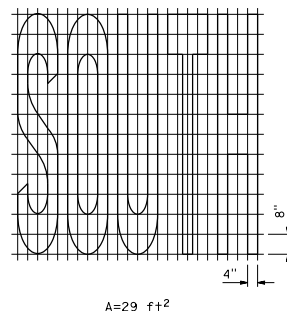
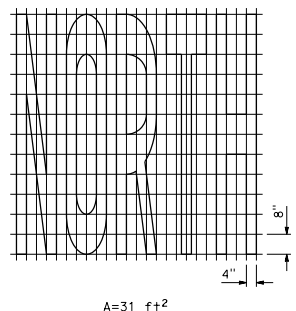
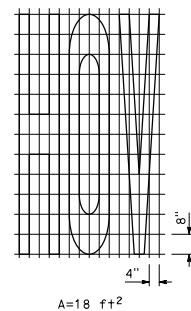
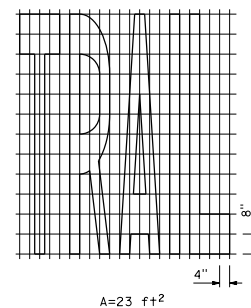
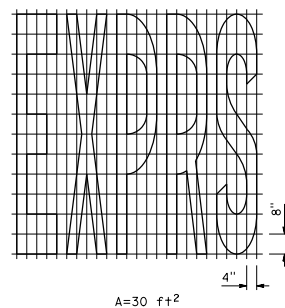
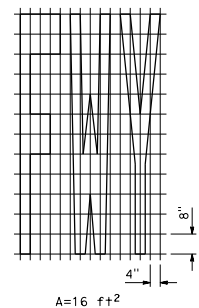
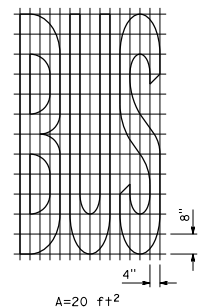
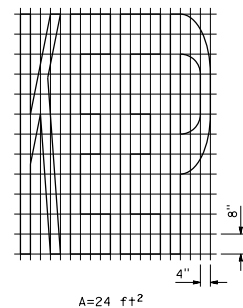
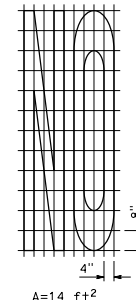
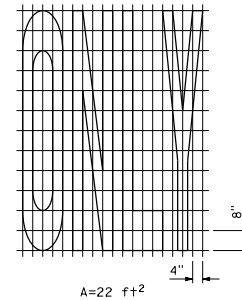
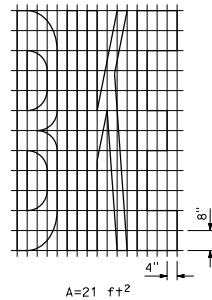
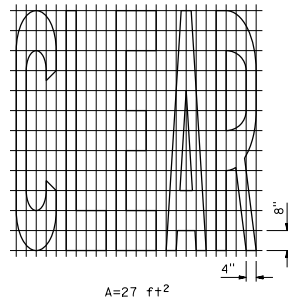
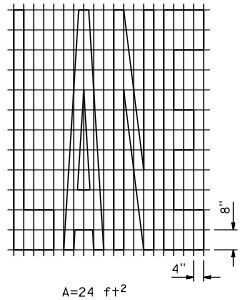

Dist	COUNTY	ROUTE	POST MILES TOTAL PROJECT	SHEET TOTAL NO. SHEETS

*Florencia Allenger*  
REGISTERED CIVIL ENGINEER

September 20, 2024  
PLANS APPROVAL DATE

*Florencia Allenger*  
No. C81705  
Exp. 3-31-26  
CIVIL  
REGISTERED PROFESSIONAL ENGINEER  
STATE OF CALIFORNIA

THE STATE OF CALIFORNIA OR ITS OFFICERS OR AGENTS SHALL NOT BE RESPONSIBLE FOR THE ACCURACY OR COMPLETENESS OF SCANNED COPIES OF THIS PLAN SHEET.

- NOTES:**
1. If a message consists of more than one word, it must read "UP", i.e., the first word must be nearest the driver.
  2. The space between words must be at least four times the height of the characters for low speed roads, but not more than ten times the height of the characters. The space may be reduced appropriately where there is limited space because of local conditions.
  3. Minor variations in dimensions may be accepted by the Engineer.
  4. Portions of a letter, number, or symbol may be separated by connecting segments not to exceed 2" in width.
  5. The words "NO PARKING" pavement marking is to be used for parking facilities. For typical locations of markings, see Standard Plans A90A and A90B.
  6. The words "NO PARKING", shall be painted in white letters no less than 1'-0" high on a contrasting background and located so that it is visible to traffic enforcement officials.

WORD MARKINGS					
ITEM	SOFT	ITEM	SOFT	ITEM	SOFT
LANE	24	EXPRS	30	FWY	16
CLEAR	27	NO	14	NORTH	31
KEEP	24	BIKE	21	SOUTH	29
HOV	18	BUS	20	EAST	22
TRAIL	23	ONLY	22	WEST	24

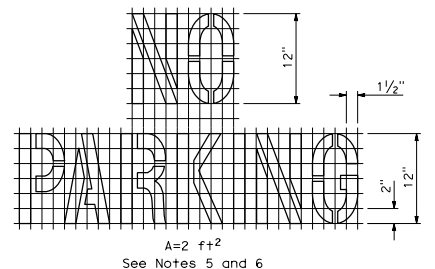

STATE OF CALIFORNIA  
DEPARTMENT OF TRANSPORTATION  
**PAVEMENT MARKINGS  
WORDS**  
NO SCALE

**A 24E**

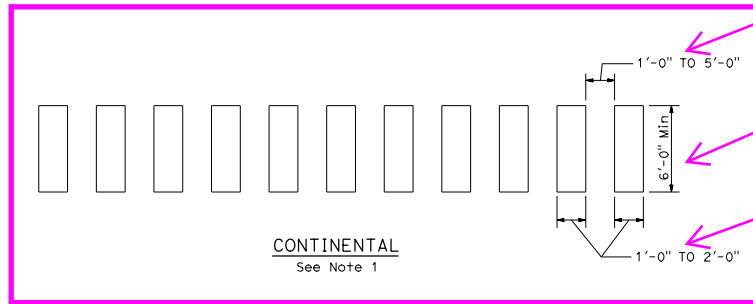

**CONTINENTAL**  
See Note 1

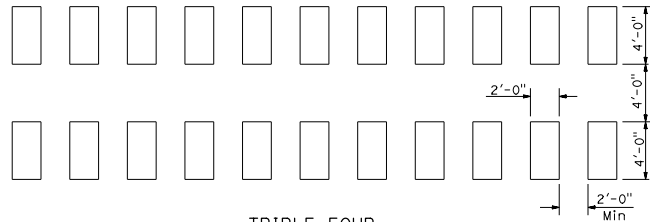

**TRIPLE FOUR**  
See Note 1

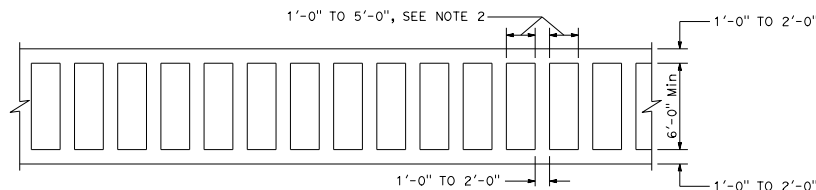

**LADDER**

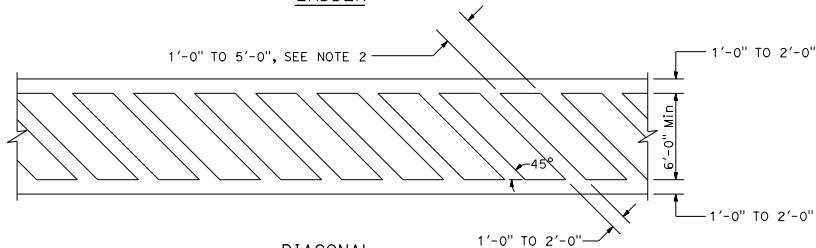

**DIAGONAL**

**HIGHER VISIBILITY CROSSWALKS**

2'-0" SPACING

MATCH EXISTING  
(8'-0" MINIMUM)

2'-0" WIDTH

**NOTES:**

1. Spaces between markings must be placed in wheel tracks of each lane.
2. Spacings not to exceed 2.5 x width of longitudinal line.
3. All crosswalk markings must be white except those near schools must be yellow.

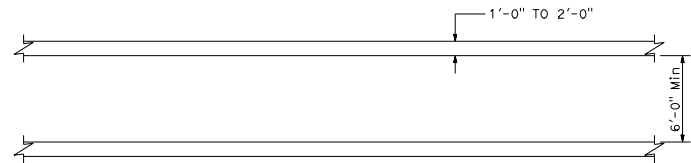

**BASIC**

STATE OF CALIFORNIA  
DEPARTMENT OF TRANSPORTATION  
**PAVEMENT MARKINGS  
CROSSWALKS**  
NO SCALE

**A 24F**

DIST	COUNTY	ROUTE	POST MILES TOTAL PROJECT	SHEET NO.	TOTAL SHEETS

REGISTERED CIVIL ENGINEER  
 Florence Allinger  
 No. C81705  
 Exp. 3-31-26  
 CIVIL  
 STATE OF CALIFORNIA

September 20, 2024  
 PLANS APPROVAL DATE  
 THE STATE OF CALIFORNIA OR ITS OFFICERS  
 OR AGENTS SHALL NOT BE RESPONSIBLE FOR  
 THE ACCURACY OR COMPLETENESS OF SCANNED  
 COPIES OF THIS PLAN SHEET.

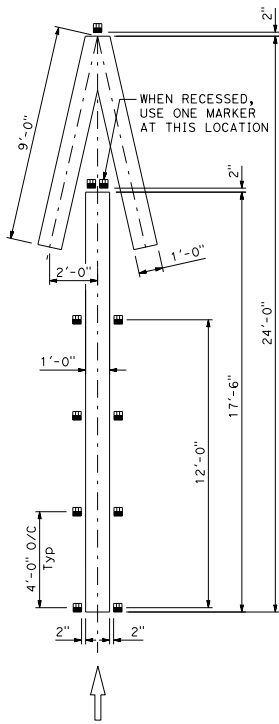

**TYPE I ARROW AT EXIT RAMP**

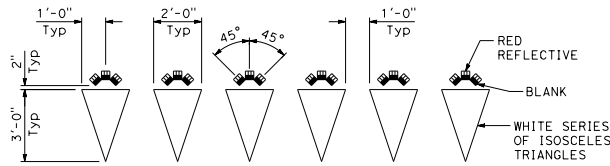

**YIELD LINE AT EXIT RAMP**

(Markers are not recessed)

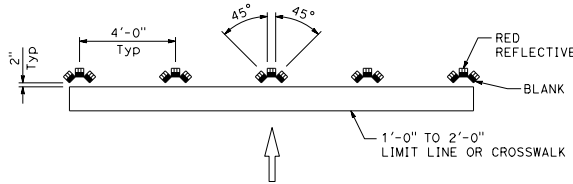

**LIMIT LINE (STOP LINE) AT EXIT RAMP**

(Markers are not recessed)

**NOTE:**

- 1. If there is crosswalk at the end of the exit ramp, place Type R markers in front of the first line for wrong way vehicle that travels up the ramp with the red reflective side facing the intersection.

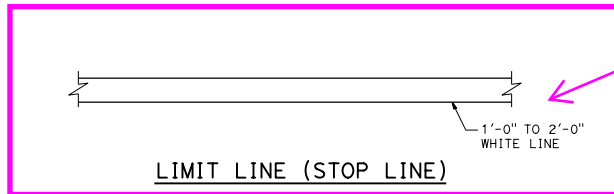

**LIMIT LINE (STOP LINE)**

1'-0" LINE

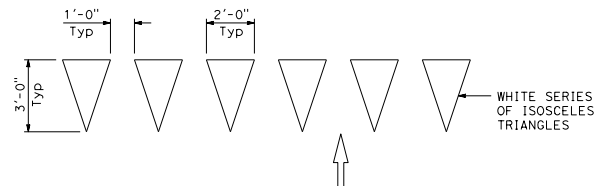

**YIELD LINE**

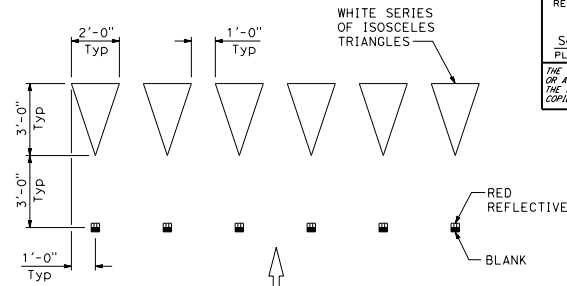

**YIELD LINE AT EXIT RAMP**

(Markers are recessed)

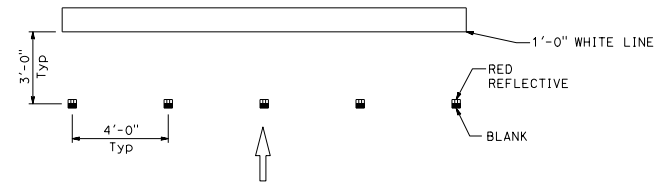

**LIMIT LINE (STOP LINE) AT EXIT RAMP**

(Markers are recessed)

D18+	COUNTY	ROUTE	POST MILES TOTAL PROJECT	SHEET TOTAL SHEETS

Registered Civil Engineer  
 September 20, 2024  
 PLANS APPROVAL DATE  
 THE STATE OF CALIFORNIA OR ITS OFFICERS OR AGENTS SHALL NOT BE RESPONSIBLE FOR THE ACCURACY OR COMPLETENESS OF SCANNED COPIES OF THIS PLAN SHEET.

REGISTERED PROFESSIONAL ENGINEER  
 Florencia Altamirano  
 No. C81705  
 Exp. 3-31-26  
 CIVIL  
 STATE OF CALIFORNIA

**LEGEND:**

TYPE R ONE-WAY RED RETROREFLECTIVE MARKER

1'-0" WHITE LINE

RED REFLECTIVE

BLANK

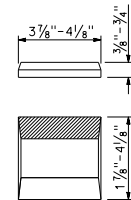

**TYPE R**

**MARKER DETAILS**

RETROREFLECTIVE FACE ON BACKSIDE

STATE OF CALIFORNIA  
 DEPARTMENT OF TRANSPORTATION  
**PAVEMENT MARKINGS**  
**YIELD LINES, LIMIT LINES**  
**AND WRONG WAY DETAILS**  
 NO SCALE

**A24G**

## **EXHIBIT "C"**

### **SPECIAL CONDITIONS**

#### **ARTICLE 1. BONDS**

Within ten (10) calendar days from the date the Contractor is notified of award of the Contract, the Contractor shall deliver to the City four identical counterparts of Payment Bond on the form supplied by the City and included as Exhibit "F" to the Contract. The surety supplying the bond must be an admitted surety insurer, as defined in Code of Civil Procedure Section 995.120, authorized to do business as such in the State of California and satisfactory to the City. The Payment Bond shall be for one hundred percent (100%) of the Total Contract Price.

#### **ARTICLE 2. Reverse Liquidated Damages Due to Unreasonable City Delay.**

In compliance with the provisions of California Public Contract Code § 7102, the Contractor will be compensated for damages incurred due to delays in completing the Work due solely to the fault of the City, where such delay is unreasonable under the circumstances and not contemplated by the parties and such delay is not the result of Additional Work. The Contractor and City agree that determining actual damages is impracticable and extremely difficult. As such, the Contractor shall be entitled to the appropriate time extension and to payment of liquidated damages in the sum of \$400 per Day of delay in excess of the time specified for the completion of the Work. Such amount shall constitute the only payment allowed and shall necessarily include all overhead (direct or indirect), all profit, all administrative costs, all bond costs, all labor, materials, equipment and rental costs, and any other costs, expenses and fees incurred or sustained as a result of such delay. The Contractor expressly agrees to be limited solely to the liquidated damages for all such delays as defined in this subsection.

**EXHIBIT "D"**

**CERTIFICATION  
LABOR CODE - SECTION 1861**

I, the undersigned Contractor, am aware of the provisions of Section 3700, et seq., of the California Labor Code which require every employer to be insured against liability for Worker's Compensation or to undertake self-insurance in accordance with the provisions of the Code, and I, the undersigned Contractor, agree to and will comply with such provisions before commencing the performance of the Work on this Contract.

**Consolidated Engineering, Inc.**

By: \_\_\_\_\_  
Signature

\_\_\_\_\_  
Name (Print)

\_\_\_\_\_  
Title (Print)

**EXHIBIT “E”**

**PUBLIC WORKS CONTRACTOR REGISTRATION CERTIFICATION**

Pursuant to Labor Code sections 1725.5 and 1771.1, all contractors and subcontractors that wish to bid on, be listed in a bid proposal, or enter into a contract to perform public work must be registered with the Department of Industrial Relations. See <http://www.dir.ca.gov/Public-Works/PublicWorks.html> for additional information.

No bid will be accepted nor any contract entered into without proof of the contractor’s and subcontractors’ current registration with the Department of Industrial Relations to perform public work.

Contractor hereby certifies that it is aware of the registration requirements set forth in Labor Code sections 1725.5 and 1771.1 and is currently registered as a contractor with the Department of Industrial Relations.<sup>1</sup>

Name of Contractor: \_\_\_\_\_

DIR Registration Number: \_\_\_\_\_

DIR Registration Expiration: \_\_\_\_\_

Small Project Exemption: \_\_\_\_\_ Yes or \_\_\_\_\_ No

Unless Contractor is exempt pursuant to the small project exemption, Contractor further acknowledges:

- Contractor shall maintain a current DIR registration for the duration of the project.
- Contractor shall include the requirements of Labor Code sections 1725.5 and 1771.1 in its contract with subcontractors and ensure that all subcontractors are registered at the time of bid opening and maintain registration status for the duration of the project.
- Failure to submit this form or comply with any of the above requirements may result in a finding that the bid is non-responsive.

Name of Contractor \_\_\_\_\_

Signature \_\_\_\_\_

Name and Title \_\_\_\_\_

Dated \_\_\_\_\_

---

<sup>1</sup> If the Project is exempt from the contractor registration requirements pursuant to the small project exemption under Labor Code Sections 1725.5 and 1771.1, please mark “Yes” in response to “Small Project Exemption.”

**EXHIBIT "F"**  
**PAYMENT BOND**

**PAYMENT BOND**

KNOW ALL MEN BY THESE PRESENTS That

WHEREAS, the City of Atwater (hereinafter designated as the "City"), by action taken or a resolution passed \_\_\_\_\_, 20\_\_\_\_has awarded to Consolidated Engineering, Inc. hereinafter designated as the "Principal," a contract for the work described as follows:

\_\_\_\_\_ (the "Project"); and

WHEREAS, the work to be performed by the Principal is more particularly set forth in the Contract Documents for the Project dated \_\_\_\_\_ ("Contract Documents"), the terms and conditions of which are expressly incorporated by reference; and

WHEREAS, said Principal is required to furnish a bond in connection with said contract; providing that if said Principal or any of its Subcontractors shall fail to pay for any materials, provisions, provender, equipment, or other supplies used in, upon, for or about the performance of the work contracted to be done, or for any work or labor done thereon of any kind, or for amounts due under the Unemployment Insurance Code or for any amounts required to be deducted, withheld, and paid over to the Employment Development Department from the wages of employees of said Principal and its Subcontractors with respect to such work or labor the Surety on this bond will pay for the same to the extent hereinafter set forth.

NOW THEREFORE, we, the Principal and \_\_\_\_\_ as Surety, are held and firmly bound unto the City in the penal sum of \_\_\_\_\_ Dollars (\$\_\_\_\_\_) lawful money of the United States of America, for the payment of which sum well and truly to be made, we bind ourselves, our heirs, executors, administrators, successors and assigns, jointly and severally, firmly by these presents.

THE CONDITION OF THIS OBLIGATION IS SUCH that if said Principal, his or its subcontractors, heirs, executors, administrators, successors or assigns, shall fail to pay any of the persons named in Section 9100 of the Civil Code, fail to pay for any materials, provisions or other supplies, used in, upon, for or about the performance of the work contracted to be done, or for any work or labor thereon of any kind, or amounts due under the Unemployment Insurance Code with respect to work or labor performed under the contract, or for any amounts required to be deducted, withheld, and paid over to the Employment Development Department or Franchise Tax Board from the wages of employees of the contractor and his subcontractors pursuant to Section 18663 of the Revenue and Taxation Code, with respect to such work and labor the Surety or Sureties will pay for the same, in an amount not exceeding the sum herein above specified.

This bond shall inure to the benefit of any of the persons named in Section 9100 of the Civil Code so as to give a right of action to such persons or their assigns in any suit brought upon this bond.

It is further stipulated and agreed that the Surety on this bond shall not be exonerated or released from the obligation of this bond by any change, extension of time for performance, addition, alteration or modification in, to, or of any contract, plans, specifications, or agreement pertaining or relating to any scheme or work of improvement herein above described, or pertaining or relating to the furnishing of labor, materials, or equipment therefore, nor by any change or modification of any terms of payment or extension of the time for any payment pertaining or relating to any scheme or work of improvement herein above described, nor by any rescission or attempted rescission of the contract, agreement or bond, nor by any conditions precedent or subsequent in the bond attempting to limit the right of recovery of claimants otherwise entitled to

recover under any such contract or agreement or under the bond, nor by any fraud practiced by any person other than the claimant seeking to recover on the bond and that this bond be construed most strongly against the Surety and in favor of all persons for whose benefit such bond is given, and under no circumstances shall Surety be released from liability to those for whose benefit such bond has been given, by reason of any breach of contract between the owner or City and original contractor or on the part of any obligee named in such bond, but the sole conditions of recovery shall be that claimant is a person described in Section 9100 of the Civil Code, and has not been paid the full amount of his claim and that Surety does hereby waive notice of any such change, extension of time, addition, alteration or modification herein mentioned and the provisions of sections 2819 and 2845 of the California Civil Code.

IN WITNESS WHEREOF, we have hereunto set our hands and seals this \_\_\_\_\_ day of \_\_\_\_\_, 20\_\_.

(Corporate Seal)

\_\_\_\_\_  
Contractor/ Principal

By \_\_\_\_\_

Title \_\_\_\_\_

(Corporate Seal)

\_\_\_\_\_  
Surety

By \_\_\_\_\_  
Attorney-in-Fact

Title \_\_\_\_\_

Signatures of those signing for the Contractor and Surety must be notarized and evidence of corporate authority attached. A Power-of-Attorney authorizing the person signing on behalf of the Surety to do so must be attached hereto.

NOTE: A copy of the Power-of-Attorney authorizing the person signing on behalf of the Surety to do so must be attached hereto.

# Notary Acknowledgment

A notary public or other officer completing this certificate verifies only the identity of the individual who signed the document to which this certificate is attached, and not the truthfulness, accuracy, or validity of that document.

STATE OF CALIFORNIA  
 COUNTY OF \_\_\_\_\_

On \_\_\_\_\_, 20\_\_\_\_, before me, \_\_\_\_\_, Notary Public, personally appeared \_\_\_\_\_, who proved to me on the basis of satisfactory

evidence to be the person(s) whose name(s) is/are subscribed to the within instrument and acknowledged to me that he/she/they executed the same in his/her/their authorized capacity(ies), and that by his/her/their signature(s) on the instrument the person(s), or the entity upon behalf of which the person(s) acted, executed the instrument.

I certify under PENALTY OF PERJURY under the laws of the State of California that the foregoing paragraph is true and correct.

WITNESS my hand and official seal.

Signature of Notary Public \_\_\_\_\_

### OPTIONAL

*Though the information below is not required by law, it may prove valuable to persons relying on the document and could prevent fraudulent removal and reattachment of this form to another document.*

#### CAPACITY CLAIMED BY SIGNER

- Individual
- Corporate Officer

\_\_\_\_\_ Title(s)

- Partner(s)                       Limited
- General
- Attorney-In-Fact
- Trustee(s)
- Guardian/Conservator
- Other:

Signer is representing:  
 Name Of Person(s) Or Entity(ies)

\_\_\_\_\_  
 \_\_\_\_\_

#### DESCRIPTION OF ATTACHED DOCUMENT

\_\_\_\_\_ Title or Type of Document

\_\_\_\_\_ Number of Pages

\_\_\_\_\_ Date of Document

\_\_\_\_\_ Signer(s) Other Than Named Above

**Exhibit G**  
**Fleet Compliance Certification.**

Bidder hereby acknowledges that they have reviewed the California Air Resources Board’s policies, rules and regulations and are familiar with the requirements of Title 13, California Code of Regulations, Division 3, Chapter 9, effective on January 1, 2024 (the “Regulation”). Bidder hereby certifies, subject to penalty for perjury, that the option checked below relating to the Bidder’s fleet, and/or that of their subcontractor(s) (“Fleet”) is true and correct:

- The Fleet is subject to the requirements of the Regulation, and the appropriate Certificate(s) of Reported Compliance have been attached hereto.
- The Fleet is exempt from the Regulation under section 2449.1(f)(2), and a signed description of the subject vehicles, and reasoning for exemption has been attached hereto.
- Bidder and/or their subcontractor is unable to procure R99 or R100 renewable diesel fuel as defined in the Regulation pursuant to section 2449.1(f)(3). Bidder shall keep detailed records describing the normal refueling methods, their attempts to procure renewable diesel fuel and proof that shows they were not able to procure renewable diesel (i.e. third party correspondence or vendor bids).
- The Fleet is exempt from the requirements of the Regulation pursuant to section 2449(i)(4) because this Project has been deemed an Emergency, as defined under section 2449(c)(18). Bidder shall only operate the exempted vehicles in the emergency situation and records of the exempted vehicles must be maintained, pursuant to section 2449(i)(4).
- The Fleet does not fall under the Regulation or are otherwise exempted and a detailed reasoning is attached hereto.

Name of Bidder: \_\_\_\_\_

Signature: \_\_\_\_\_

Name: \_\_\_\_\_

Title: \_\_\_\_\_

Date: \_\_\_\_\_



## CITY COUNCIL AGENDA REPORT

### CITY COUNCIL

Mike Nelson, Mayor  
Danny Ambriz      Brian Raymond  
John Cale              Kalisa Rochester

**MEETING DATE:** June 9, 2025  
**TO:** Mayor and City Council  
**FROM:** Christopher Hoem, City Manager  
**PREPARED BY:** Christopher Hoem, City Manager  
**SUBJECT:** **Community Development Director Employment Agreement (City Manager Hoem)**

---

### **RECOMMENDED COUNCIL ACTION**

Motion to adopt Resolution No. 3541-25 to ratify the Community Development Director Employment Agreement in the annual amount of \$135,657.96 plus benefits with Jon O'Connor, in a form approved by the City Attorney; and authorize and direct the City Manager to execute the Agreement on behalf of the City; or

Motion to approve staff's recommendation as presented.

### **I. BACKGROUND/ANALYSIS:**

The Community Development Director position is a key management position in the operation of City business. Failure to maintain appropriate staffing levels in critical leadership positions limits the City's ability to ensure public safety, plan for the future, and maintain effective organizational operations. The appointment of a new Community Development Director will reaffirm to the community and staff the City's commitment to maintaining effective leadership in the Community Development Department.

In March 2025, the City conducted recruitment efforts for the new Community Development Director. The City Manager interviewed candidates and determined that Mr. O'Connor is the preferred candidate. Mr. O'Connor was issued a Conditional Offer of Employment with an anticipated start date of June 10, 2025. Mr. O'Connor brings over 20 years of public and private sector experience in real estate development, project management, and community planning. He has led successful initiatives in economic development, partnerships, and regulatory compliance across multiple jurisdictions in California. His government service includes advisory, leadership, and consultancy roles with the City of Eureka and the City of Arcata, among others. He holds a Bachelor's degree in Religious Studies from Humboldt State University (now Cal Poly Humboldt) and a Master of Science in Organizational Leadership from National University.

The City Manager negotiated a Community Development Director Employment Agreement (Agreement) with Mr. O'Connor. The employment agreement is being presented to the City Council for ratification.

The Agreement contains the following proposed provisions:

- The Community Development Director's salary shall be \$135,657.96 per year.
- The Agreement is for an indefinite term and constitutes at-will employment, meaning the Community Development Director may be terminated at any time, with or without cause, and without an expiration date.
- The City shall pay the Community Development Director's premiums for him and his qualified dependents' medical, dental, and vision insurance on the same terms and conditions as are offered to other similarly situated City employees.
- The City shall provide the Community Development Director a City vehicle to use for City business only.
- The City shall provide relocation assistance, up to \$10,000, for reasonable and documented relocation expenses.
- If the Community Development Director is terminated without cause, he shall be entitled to severance in the amount of four (4) months of wages.
- The Community Development Director will receive leave similar to that of other similarly situated City employees.

**II. FISCAL IMPACTS:**

Sufficient funding is available in the General Fund, Community Development, Account No. 0001-4000-1001. No additional fiscal impacts are associated with the Agreement. This item has been reviewed by the Finance Department.

**III. LEGAL REVIEW:**

This item has been reviewed by the City Attorney's Office.

**IV. EXISTING POLICY:**

This item is consistent with goal numbers one (1), two (2) and five (5) of the City's Strategic Plan: to ensure the City's continued financial stability, to ensure the City's safety of staff and our community, and to optimize organizational structure, respectively.

**V. ALTERNATIVES:**

N/A

**VI. INTERDEPARTMENTAL COORDINATION:**

This item was coordinated by the City Manager's Office, Human Resources Department, and Finance Department.

**VII. PUBLIC PARTICIPATION:**

The purpose of ratifying employment agreements in an open session of the governing

body is to provide the public with the opportunity to provide comments prior to ratification by the City Council.

**VIII. ENVIRONMENTAL REVIEW:**

This item is not a “project” under the California Environmental Quality Act (CEQA) as this activity does not cause either a direct physical change in the environment, or a reasonably foreseeable indirect physical change in the environment, pursuant to Public Resources Code section 21065.

**IX. STEPS FOLLOWING APPROVAL:**

Upon ratification of the employment agreement by the City Council, the City Manager, City Attorney, and the employee shall execute the Agreement.

Submitted and Approved by:



---

Chris Hoem, City Manager

Attachments:

1. Resolution O'Connor Employment Agreement 6-9-25
2. Draft Agreement - Community Development Director 2025 - Jon O'Connor



**CITY COUNCIL  
OF THE  
CITY OF ATWATER**

---

**RESOLUTION NO. XXXX-24**

**A RESOLUTION OF THE CITY COUNCIL OF THE  
CITY OF ATWATER TO RATIFY THE COMMUNITY  
DEVELOPMENT DIRECTOR EMPLOYMENT  
AGREEMENT IN THE ANNUAL AMOUNT OF  
\$135,657.96 PLUS BENEFITS WITH JON  
O’CONNOR**

**WHEREAS**, recognizes the need to fill the critical executive position of Community Development Director to provide leadership and direction for the City’s planning, building, and housing; and

**WHEREAS**, the position of Community Development Director is essential to supporting the City’s goals for economic development, land use planning, housing compliance, and enhancing the overall quality of life for residents; and

**WHEREAS**, Jon O’Connor has demonstrated significant qualifications, experience, and leadership qualities, making him an exemplary candidate for the position of Community Development Director; and

**WHEREAS**, the attached employment agreement between the City and Jon O’Connor outlines terms that are fair, equitable, and in the best interest of the community, including provisions for salary, benefits, and accountability measures.

**NOW, THEREFORE, BE IT RESOLVED** by the City Council of the City of Atwater as follows:

1. The City Council hereby approves and ratifies the Employment Agreement between the City of Atwater and Jon O’Connor for the position of Community Development Director.
2. The City Manager is authorized and directed to execute the agreement on behalf of the City and to take all necessary actions to carry out the terms of the agreement.
3. This resolution shall take effect on June 10, 2025.

The foregoing resolution is hereby adopted this 9<sup>th</sup> day of June 2025.

**AYES:**

**NOES:**

**ABSENT:**

**APPROVED:**

\_\_\_\_\_  
**MIKE NELSON, MAYOR**

**ATTEST:**

\_\_\_\_\_  
**KORY J. BILLINGS, CITY CLERK**

**COMMUNITY DEVELOPMENT DIRECTOR  
EMPLOYMENT AGREEMENT**

**THIS EMPLOYMENT AGREEMENT** (the "Agreement") is made and entered into as of the \_\_\_ day of June 2025, ("Effective Date"), by and between the CITY OF ATWATER ("City") and **JON O'CONNOR** ("Employee"). The City and Employee shall be referred to herein individually as a "Party" and collectively as "Parties." There are no other parties to this Agreement.

**RECITALS**

- A. The City Manager is authorized to negotiate and enter into employment agreements with Department Directors subject to the advice and consent of the Atwater City Council ("City Council") pursuant to the terms of the Atwater Municipal Code ("Municipal Code").
- B. The Parties agree that this Agreement shall be the sole agreement between the Parties regarding the employment of Employee as Community Development Director.
- C. The Parties desire to execute this Agreement pursuant to the authority of, and subject to, the provisions of California Government Code ("Government Code") section 53260 *et seq.*

**NOW, THEREFORE**, in consideration of the mutual covenants entered into between the Parties, and in consideration of the benefits that accrue to each, it is agreed as follows:

**AGREEMENT**

**Section 1. Recitals.** The recitals set forth above ("Recitals") are incorporated herein by this reference and made a part of this Agreement. In the event of any inconsistencies between Recitals and Section 1 through 9 of this Agreement, Sections 1 through 9 will prevail.

**Section 2. Appointment of Community Development Director, Duties, and Term.**

**Section 2.1. Appointment of Community Development Director and Duties.** With the consent of and ratification by the City Council on June 9, 2025, the City Manager hereby appoints Employee to the position of Community Development Director, effective June 10, 2025, in and for the City, to perform the function and duties of the Community Development Director, under the direction of the City Manager. Employee accepts such appointment and employment pursuant to the terms of this Agreement.

**Section 2.2. Secondary Employment/Conflict of Interest.** Employee agrees to devote all productive time, ability, and attention to the City's business to the extent necessary to perform the duties and responsibilities in a manner satisfactory to City.

A) Employee shall not hold secondary employment or engage in activities which conflict with, or present the appearance or possibility of conflicting with, City's business interests. As such, Employee agrees that Employee will notify the City Manager in writing if Employee accepts secondary employment, so that the City may determine whether there is a conflict or potential conflict with the satisfactory performance of Employee's duties and/or the best interest of the City. Employee has the right to volunteer for such nonprofit organizations as he may see fit, provided that such volunteer services do not interfere with the duties as Community Development Director or conflict with, or present the appearance or possibility of conflicting with, the City's business interests.

B) Employee shall not engage in any activity that is, or may create, a conflict of interest, prohibited contract, or that may create an incompatibility of office under state law. Prior to performing services under this Agreement, and annually thereafter, Employee must complete financial disclosure forms required by law.

**Section 2.3. Exempt Employee.** Typical general business hours for City employees are Monday through Friday, 8:00 AM to 5:00 PM. However, it is recognized by the Parties that Employee is an exempt employee for purposes of the Fair Labor Standards Act of 1938 (29 U.S.C. § 201 *et seq.*). Employee shall not receive overtime or extra compensation for hours worked outside of the City's general business hours, which are necessary to fulfill the duties of the Community Development Director, unless otherwise provided in this Agreement.

**Section 2.4. Duties/Schedule.** The Community Development Director's daily and weekly work schedule shall vary in accordance with the work required to be performed. The Community Development Director position may include frequent attendance at evening meetings and frequent irregular hours as necessary to meet deadlines and achieve objectives. The City Manager recognizes that the Community Development Director must devote a great deal of time outside normal office hours to business of the City and, to that end, will be allowed to take Administrative Leave, as defined in Section 4.4 of this Agreement, as he shall deem appropriate during said normal office hours, subject to notification and approval of the City Manager.

The Community Development Director's primary duties shall be as summarized in the job description attached hereto as **Exhibit A**. Employee shall perform Employee's duties under this Agreement pursuant to the laws of the State of California and applicable City Municipal Code, ordinances, and resolutions.

Employee understands that Employee's duties may be amended from time to time by the City Manager as necessary to meet the City's needs. No modification or change in Employee's responsibilities, duties or position shall otherwise change or revoke any other provision of this Agreement.

Unless otherwise specified in this Agreement, Employee shall be bound by all the policies, rules, and regulations of the City now in force and effect and applicable to Employee's position, and by all such other applicable policies, rules and regulations as may be hereafter implemented and called to his notice and will faithfully observe and abide by the same. No such policy, rule or regulation shall alter, modify or revoke employee's status as an at-will employee or any other provision of this Agreement.

### **Section 3. At-Will Employment.**

**Section 3.1. At-Will.** Employee is an at-will employee serving at the pleasure of the City Manager, as provided in Government Code section 34856. Accordingly, the City Manager may terminate Employee's employment at any time, with or without cause.

**Section 3.2. No Property Right in Employment.** Employee understands and agrees that the terms of employment are governed only by this Agreement and that no right of employment for any specific term is created by this Agreement. Employee further understands that based on the "at-will" employment status, Employee acquires no property interest in employment by virtue of this Agreement, and that Employee is not entitled to due process for any disciplinary actions under the City's personnel policies and rules.

### **Section 4. Compensation and Benefits**

**Section 4.1 Community Development Director Salary.** Beginning June 10, 2025, Employee shall be compensated at Step 2 of Grade 337 of the Salary Schedule (currently in the amount of \$11,304.83 per month/\$135,657.96 per year) for services performed as Community Development Director. This position is exempt from any City furlough program. Employee's performance shall be reviewed annually pursuant to the City's Performance Evaluation Policy and Employee shall be eligible to have his salary adjusted annually thereafter as set forth in the Salary Schedule, consistent with the Mid Managers Group, or Department Director Group (if established), whichever provides the greater benefit to Employee.

**Section 4.2. Review and Evaluation.** The City Manager agrees to review and evaluate Employee's performance of Employee's duties as Community Development Director, pursuant to the terms of this Agreement ("Review and

Evaluation”), on not less than an annual basis and to provide Employee with a written performance review. The annual Review and Evaluation shall be conducted on or about the anniversary date of this Agreement of each year, or at the City Manager’s discretion.

**Section 4.3. Vehicle.** During the term, or any extension thereof, the City will provide Employee with an assigned vehicle to be used to and from home and work and will cover the costs and expenses associated with said vehicle. In the event Employee requests and is authorized to use a private vehicle for City business, he shall be reimbursed for mileage in accordance with City policies.

**Section 4.4. Administrative Leave.** It is recognized that Employee must devote a great deal of time outside the normal office hours to City business as Community Development Director. To that end, Employee shall receive up to eighty (80) hours of administrative leave (“Administrative Leave”) per calendar year, to be used as needed, upon the approval of the City Manager. Approved but unused Administrative Leave may be cashed out annually at the discretion of the City Manager and only if budgeted funds are available to permit the cash out, and Employee has elected for cash out in advance of earning the time. Administrative Leave is only available for use or cash out in the year in which it is given, has no other cash value, and may not be carried over into a subsequent year.

**Section 4.5. Sick and Vacation Leave.**

**Section 4.5.1 Sick Leave.** Employee shall accrue four (4) hours of sick leave each pay period over 24 pay periods a year. Employee shall be permitted to cash out up to ninety-six (96) hours of accrued and unused sick leave annually pursuant to City policy at the discretion of the City Manager and only if budgeted funds are available to permit the cash out. There is no cap on sick leave accruals. If employee’s employment with the City terminates, sick leave shall be paid out pursuant to the City’s Paid Sick Leave Policy on the same terms and conditions as are offered to other City employees, consistent with the Mid Managers Group, or Department Director Group (if established), whichever provides the greater benefit to Employee.

**Section 4.5.2. Vacation Leave.** In recognition of Employee’s years of experience, Employee shall accrue five (5) hours of vacation leave per pay period over 24 pay periods a year. For the purposes of the vacation leave accrual rate, Employee shall be considered to have been hired five years prior to the effective date of appointment of Employee. Employee may cash out up to eighty (80) hours of accrued, unused vacation annually at the discretion of the City Manager and only if budgeted funds are available to permit the cash

out, and Employee has elected for cash out in advance of earning the time. Accruals are capped at twice the annual accrual amount.

**Section 4.6. Holidays.** Employee shall be subject to the provisions governing Holidays as are set forth in the City's Personnel Rules and Regulations.

**Section 4.7. Medical, Dental and Vision.**

**4.7.1. Medical, Dental and Vision.** During the Term of this Agreement, or any extension hereof, the City shall pay the premiums for Employee and qualified dependents' for medical, dental and vision insurance on the same terms and conditions as are offered to other similarly situated City employees, consistent with the tier system utilized for the Mid Managers Group or Department Director Group (if established), whichever provides the greater benefit to Employee. Employee shall be responsible for the payment of any premiums not paid for by the City and all deductibles, co-payments and disallowed costs. Should Employee elect not to participate in the City's medical plan or elect to enroll in medical coverage through a spouse, Employee shall be eligible for in-lieu payments in the amount set for the Mid Managers Group or Department Director Group (if established), whichever provides the greater benefit to Employee.

**4.7.2 Medical Upon Retirement.** If Employee is a qualified annuitant under the requirements of CalPERS and the effective date of retirement is less than one hundred and twenty (120) days after separation from employment with the City, Employee may elect to participate in the City's medical insurance plans. If qualified for enrollment, the City shall pay the premiums consistent with the tier system utilized for the Mid Managers Group or Department Director Group (if established), whichever provides the greater benefit to Employee at the time of Employee's retirement. Employee shall be responsible for the payment of any premiums not paid for by the City and all deductibles, co-payments and disallowed costs. When Employee and qualified dependents become eligible for Medicare, the City's medical insurance plan shall become secondary insurance and the City's obligation to pay premiums as set forth in this Section shall be reduced accordingly.

**4.7.3 Dental and Vision Upon Retirement.** Upon Employee's retirement from the City, Employee and eligible dependents may elect to remain on the City's dental and/or vision coverage plans. Employee will be responsible for paying the full amount of the monthly premium amounts for Employee and eligible dependents, established by the City's provider, as well as all deductibles, co-

payments, and disallowed costs. Said amounts are subject to change annually. The City shall bill Employee on a monthly basis for the full amount of the monthly premiums. Non-payment will result in disenrollment of Employee and eligible dependents without the option to re-enroll.

**Section 4.8. Retirement.** The City participates in the California Public Employees' Retirement System (CalPERS). CalPERS will make the determination if Employee is considered a "Classic" member or "New" member" (as defined in the Government Code), and Employee shall contribute based on the enrolled tier. Employee shall pay 100% of the employee contribution.

**Section 4.9. Life Insurance and Accidental Death and Dismemberment.** During the term of this Agreement, or any extension hereof, the City shall pay 100% of all premiums per existing policy in place at time of agreement to cover the life insurance policy currently in place for the benefit of Employee.

**Section 4.10. Disability.** During the term of this Agreement, or any extension hereof, the City shall pay 100% of all premiums per existing policy in place at time of agreement to cover both short term and long-term disability benefits for the benefit of Employee.

**Section 4.11. Unemployment.** During the term of this Agreement, or any extension hereof, the City shall contribute to the Unemployment Insurance Program for the benefit of Employee, at no cost to Employee.

**Section 4.12. Changes in Fringe Benefits or Working Conditions.** Except as otherwise provided herein, all provisions of the Rules and Regulations of the City relating to changes to fringe benefits and/or working conditions as they now exist, or hereinafter may be amended, shall also apply to Employee as they would to other similarly situated City employees, consistent with the policy for the Mid Managers Group or Department Director Group (if established), in addition to the benefits enumerated for the benefit of Employee as herein provided.

**Section 4.13. Professional Development.** Subject to available funds, the City agrees to pay the professional dues, subscriptions, travel, lodging, meals, training expenses and other business expenses of Employee reasonably necessary for continued and full participation in national, state, and local associations, professional organizations, governmental groups and committees thereof for the good of the City in accordance with the approved budget. For the purposes of this section, all expenses shall be reasonable actual expenses, and Employee shall submit appropriate documentation of expenses.

**Section 4.14. Expense Reimbursement.** The City shall reimburse Employee for all sums necessarily incurred and paid by Employee in the

performance of his duties, as approved by the City Manager. Employee shall submit a claim form or appropriate documentation to the City in compliance with City policies.

**Section 4.15. Relocation Assistance.** The Employer agrees to provide the Employee with relocation assistance in the form of reimbursement for reasonable and documented relocation expenses incurred in connection with the Employee's relocation to the Atwater, California area for the purpose of assuming the position of Community Development Director. The total amount of reimbursement shall not exceed Ten Thousand Dollars (\$10,000.00). All relocation expenses must be incurred and submitted for reimbursement within six (6) months of the Employee's start date. The Employee must submit appropriate receipts and documentation as required by the Finance Department.

## **Section 5. Termination of Employment and Severance.**

**Section 5.1. Voluntary Resignation.** Employee may resign at any time and agrees to give the City at least thirty (30) days advance written notice of the effective date of Employee's resignation, unless the Parties otherwise agree in writing. If Employee retires from full-time public service with the City, Employee shall provide ninety days (90) advance written notice. During the notice period, all rights and obligations of the Parties under this Agreement shall remain in full force and effect. Promptly after the effective date of resignation or retirement, the City shall pay to Employee all salary and other compensation due and owing under this Agreement. In the event of voluntary resignation or retirement, Employee shall not be entitled to Severance, as set forth in Section 5.3 of this Agreement.

**Section 5.2. Termination by City Manager.** The City Manager may terminate this Agreement and remove Employee from his position as Community Development Director at any time with or without cause. If Employee's termination is based on charges of misconduct that publicly stigmatizes Employee's reputation or impairs his ability to earn a living, or might damage his standing in a community, Employee may, within five (5) business days of the City Manager's notice to Employee of his or her intent to terminate Employee's employment, make a written request for a "name-clearing" hearing (as described in *Lubey v. City and County of San Francisco* (1979) 98 Cal.App.3d 340 and its progeny) before the City Council in closed session. The "name-clearing" hearing is solely to provide Employee the opportunity to clear his name. The City Council may determine whether the allegations contained in the notice of termination are supported. If the City Council determines that the allegations are not supported, a decision shall be issued to reflect that Employee's termination was without fault. This decision will not, however, require that Employee be reinstated to his position. In the event Employee does not request a "name-clearing" hearing before the City Council, the City Manager's decision to terminate will be effective by the close of business on

the fifth (5<sup>th</sup>) day after the City Manager provided notice to Employee of his or her intent to terminate Employee's employment. Should the Employee request a name clearing hearing within the five (5) days, termination will still take effect after the fifth day and Employee will not be on paid status during this period.

**Section 5.3. Termination With Severance.** This provision only relates to Employee's eligibility to receive severance pay pursuant to this Agreement and does not in any way impact Employee's at-will status. In the event the City Manager terminates Employee's employment and this Agreement without Good Cause, as defined in Section 5.4, below, or requests Employee's resignation in lieu of such termination, subject to the conditions in this subsection, Employee shall be eligible to receive a sum equal to four (4) month's Base Salary ("Severance"). Such Severance is subject to the restrictions of Government Code section 53260. Severance shall be paid in the same manner as to other similarly situated City employees unless otherwise agreed to by the City Manager and Employee. Employee's eligibility for Severance shall be expressly conditioned upon Employee's execution (and non-revocation) of: (i) a waiver and release of any and all of Employee's claims against the City, and its employees, elected officials, officers, and agents, and (ii) a covenant not to sue any of those parties. If the Employee resigns in lieu of termination, the Parties shall cooperate and agree regarding public announcements and communications regarding Employee's separation. Such waiver shall be either drafted or approved by the City Attorney prior to execution.

**Section 5.4. Termination Without Severance.** This provision only relates to Employee's ability to receive severance pay pursuant to this Agreement, and does not in any way impact Employee's at-will status. The City Manager may at any time immediately terminate this Agreement and Employee's employment for Good Cause, as defined below. If Employee is terminated for Good Cause, the City shall not be required to pay any Severance under this Agreement, and the City shall have no obligation to Employee beyond those benefits accrued as of Employee's last day of employment and those the City is obligated to provide under federal or state law.

"Good Cause" for purposes of this Agreement is defined as the following:

1. Conviction of a felony;
2. Disclosing confidential or protected information of the City;
3. Misconduct or gross carelessness in the course of Employee's work performance;
4. Unjustifiable and willful neglect of the duties described in this Agreement or Employee's job description;
5. Commission of any act of fraud in the performance of Employee's duties. In this context, "fraud" means an intentional misrepresentation, deceit, or concealment of a material fact known to Employee that deprives the City or another person of legal rights or causes injury;
6. Dishonesty;

7. Failure to perform Employee's duties to the standard set by the City, as determined by the City Manager,
8. Any conduct which violates the applicable provisions of the City's personnel policies, rules or regulations for which an employee may be terminated;
9. Repeated or protracted unexcused absences from the Employee's office and duties;
10. Conduct that in any way has a direct, substantial, and adverse effect on the City's reputation or the Administration Department whether during or outside business hours;
11. Violation of federal, state, or City discrimination laws;
12. Refusal to take or subscribe any oath or affirmation which is required by law;
13. Employee's disability resulting in his inability to perform the essential functions of his job, which the City is unable to reasonably accommodate without placing an undue burden on City business operations;
14. Engaging in other employment or activities which conflict with, or present the appearance or possibility of conflicting with, City's legitimate business interests; or
15. Substance abuse which adversely affects performance of Employee's duties.

The City Manager may also place Employee on paid or unpaid investigatory leave during the Term of this Agreement.

**Section 6. Notices.** Any notice or communication required hereunder between the City and Employee must be in writing and may be given either personally, by facsimile (with original forwarded by regular U.S. Mail), by registered or certified mail (return receipt requested), or by Federal Express, UPS, or other similar couriers providing overnight delivery. If personally delivered, a notice shall be deemed to have been given when delivered to the Party to whom it is addressed. If given by facsimile transmission, a notice or communication shall be deemed to have been given and received upon actual physical receipt of the entire document by the receiving Party's facsimile machine. Notices transmitted by facsimile after 5:00 p.m. on a normal business day, or on a Saturday, Sunday or holiday shall be deemed to have been given and received on the next normal business day. If given by registered or certified mail, such notice or communication shall be deemed to have been given and received on the first to occur of (a) actual receipt by any of the addressees designated below as the Party to whom notices are to be sent, or (b) five (5) days after a registered or certified letter containing such notice, properly addressed, with postage prepaid, is deposited in the United States mail. If given by Federal Express or similar courier, a notice or communication shall be deemed to have been given and received on the date delivered, as shown on a receipt issued by the courier. Any Party hereto may at any time, by giving ten (10) days written notice to the other Party hereto, designate any other address in

substitution of the address to which such notice or communication shall be given. Such notices or communications shall be given to the Parties at their addresses set forth below:

If to Employee: City of Atwater  
Attn: Jon O'Connor  
1350 Broadway Ave  
Atwater, California 95301  
CC: Employee's home address on file

If to the City: City of Atwater  
Attn: City Manager  
1160 Fifth Street  
Atwater, California 95301

**Section 7. Indemnification.** The City shall defend, hold harmless, and indemnify Employee against any tort, personnel, civil rights, or professional liability claim or demand or other legal action, whether groundless or otherwise, arising out of an alleged act or omission occurring in the performance of Employee's duties as Community Development Director in accordance with the California Government Claims Act (Government Code section 810 *et seq.*) and shall provide a defense to Employee in accordance with Government Code sections 995-996.6. The City may decline to defend or indemnify Employee only as permitted by the Government Code. City may compromise and settle any such claim or suit and pay the amount of any resulting settlement or judgment; provided, however, the City's duty to defend and indemnify Employee shall be contingent upon Employee's good faith cooperation with such defense. In the event the City provides paid leave to the Employee pending an investigation or funds for a legal criminal defense pursuant to this Section, Employee shall reimburse the City for the amount of such paid leave or cost of the legal criminal defense, if Employee is convicted of a crime involving an abuse of office or position, as provided by Government Code sections 53243-53243.1. Also, if this Agreement is terminated, any cash settlement related to the termination that Employee may receive from the City shall be fully reimbursed to the City if Employee is convicted of a crime involving an abuse of his or her office or position as provided in Government Code section 53243.2-53243.4

**Section 8. Bonding.** The City shall bear the full cost of any fidelity or other bonds required of Employee under any law or ordinance.

**Section 9. General Provisions**

**9.1. Modification of Agreement.** This Agreement may be supplemented, amended, or modified only by a writing signed by the City Manager and Employee.

**9.2. Entire Agreement.** This Agreement constitutes the final, complete, and exclusive statement of the terms of the agreement between the Parties and supersedes all other prior or contemporaneous oral or written understandings and agreements of the Parties. No Party has been induced to enter into this Agreement by, nor is any Party relying on, any representation or warranty except those expressly set forth in this Agreement.

**9.3. Severability of Agreement.** If a court or an arbitrator of competent jurisdiction holds any section of this Agreement to be illegal, unenforceable, or invalid for any reason, the validity and enforceability of the remaining sections of this Agreement shall not be affected.

**9.4. Authority.** All Parties to this Agreement warrant and represent that they have the power and authority to enter into this Agreement and the names, titles, and capacities herein stated on behalf of any entities, persons, states, or firms represented or purported to be represented by such entities, persons, states, or firms and that all former requirements necessary or required by state or federal law in order to enter into this Agreement had been fully complied with. Further, by entering into this Agreement, neither Party hereto shall have breached the terms or conditions of any other contract or agreement to which such Party is obligated, which such breach would have a material effect hereon.

**9.5. Headings.** The headings in this Agreement are included for convenience only, and neither affect the construction or interpretation of any section in this Agreement nor affect any of the rights or obligations of the Parties to this Agreement.

**9.6. Necessary Acts and Further Assurances.** The Parties shall, at their own cost and expense, execute and deliver such further documents and instruments and shall take such other actions as may be reasonably required or appropriate to evidence or carry out the intent and purposes of this Agreement.

**9.7. Governing Law.** This Agreement shall be governed and construed in accordance with the laws of the State of California.

**9.8. Waiver.** No covenant, term, or condition, or the breach thereof, shall be deemed waived, except by written consent of the Party against whom the waiver is claimed, and any waiver of the breach of any covenant, term, or condition shall not be deemed to be a waiver of any preceding or succeeding breach of the same or any other covenant, term, or condition.

**9.9. Counterparts.** This Agreement may be executed in counterparts, including by signatures transmitted electronically or by fax, and all so executed

City of Atwater

Community Development Director  
Employment Agreement  
Page 11 of 12

shall constitute an agreement which shall be binding upon the Parties hereto, notwithstanding that the signatures of all Parties and Parties' designated representatives do not appear on the same page.

**9.10. Venue.** Venue for all legal proceedings shall be in the Superior Court in and for the County of Merced in the State of California.

**IN WITNESS WHEREOF**, this Agreement has been entered into by and between Employee and City as of the date of the Agreement set forth above.

**CITY:**

**EMPLOYEE:**

City of Atwater, a municipal corporation of the State of California

By: \_\_\_\_\_  
Chris Hoem, City Manager

By: \_\_\_\_\_  
Jon O'Connor, an individual

Date Signed:

Date Signed: \_\_\_\_\_

Approved as to Form:

By: \_\_\_\_\_  
Frank Splendorio, City Attorney